

Air pressure regulation valve -Front right (EXREXZ)

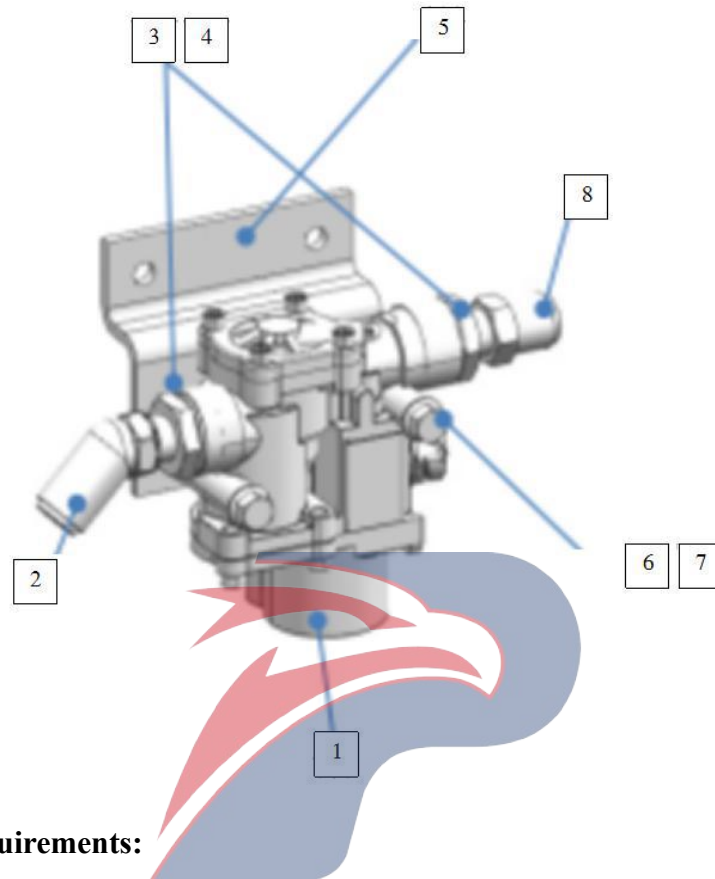

Assembly requirements:

1. Take the transition connector 3, and smear 8-10mm long thread sealant in the longitudinal direction, starting 2-3 pitches from the lowest part of the thread.
2. Put the copper washer 4 into the air pressure regulation valve 1, screw the sealant-applied connector 3 into the air pressure regulation valve 1, and tighten it two or three turns; then, loosen it two or three turns to allow the sealant to be evenly smeared onto the valve body. Tighten the connector 3.
3. Tighten the quick change connector 2 to the transition connector 3 at the air outlet end in the same way.
4. Fix the air pressure regulation valve 1 to the support 5 using the bolt 6 and the nut 7.

Assembly details:

1. Air pressure regulation valve (3203080-912/C)
2. Quick-change connector (3523223-D17YZ)
3. Transition connector (3523214-D17YZ)
4. Copper washer-air pressure regulation valve (3506904-CEH24)
5. Bracket (3523222-D15EH)
6. Bolt (Q1840880)
7. Nut (Q32008)
8. Quick change connector

Air pressure regulation valve -Front left (EXREXZ)

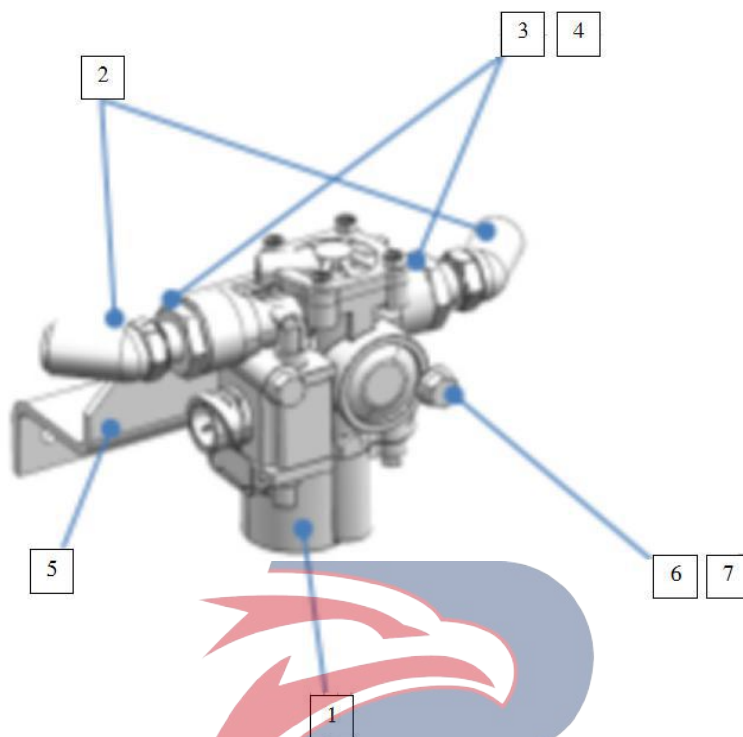

Assembly requirements:

1. Take the transition connector 3, and smear 8-10mm long thread sealant in the longitudinal direction, starting 2-3 pitches from the lowest part of the thread.
2. Put the copper washer 4 into the air pressure regulation valve 1, screw the sealant-applied connector 3 into the air pressure regulation valve 1, and tighten it two or three turns; then, loosen it two or three turns to allow the sealant to be evenly smeared onto the valve body. Tighten the connector 3.
3. Tighten the quick change connector 2 to the transition connector 3 at the air outlet end in the same way.
4. Fix the air pressure regulation valve 1 to the support 5 using the bolt 6 and the nut 7.

Assembly details:

1. Air pressure regulation valve (3203080-912/C)
2. Quick-change connector (3523223-D17YZ)
3. Transition connector (3523214-D17YZ)
4. Copper washer-air pressure regulation valve (3506904-CEH24)
5. Bracket (3523222-D15EH)
6. Bolt (Q1840880)
7. Nut (Q32008)

Air pressure regulation valve -Rear right (EXR)

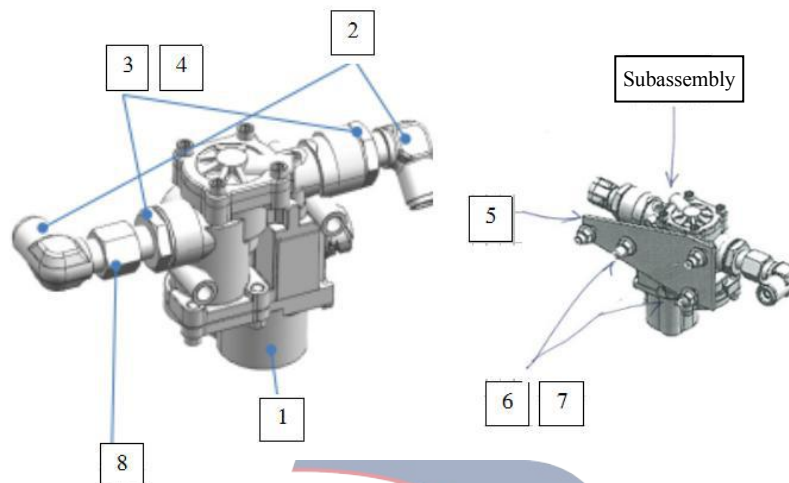

Assembly requirements:

1. Take the transition connector 3, and smear 8-10mm long thread sealant in the longitudinal direction, starting 2-3 pitches from the lowest part of the thread.
2. Put the copper washer 4 into the air pressure regulation valve 1, screw the sealant-applied connector 3 into the air pressure regulation valve 1, and tighten it two or three turns; then, loosen it two or three turns to allow the sealant to be evenly smeared onto the valve body. Tighten the connector 3.
3. Tighten the quick change connector 2 to the transition connector 3 at the air outlet end in the same way.
4. Fix the air pressure regulation valve 1 to the support 5 using the bolt 6 and the nut 7.

Assembly details:

1. Air pressure regulation valve (3203080-912/C)
2. Quick change connector
3. Transition connector (3523214-D17YZ)
4. Copper washer-air pressure regulation valve (3506904-CEH24)
5. Support (3606325-D17YZ)
6. Bolt (Q1840880)
7. Nut (Q32008)
8. Quick-change connector (3523214-D17YZ)

Air pressure regulation valve -Rear left (EXR)

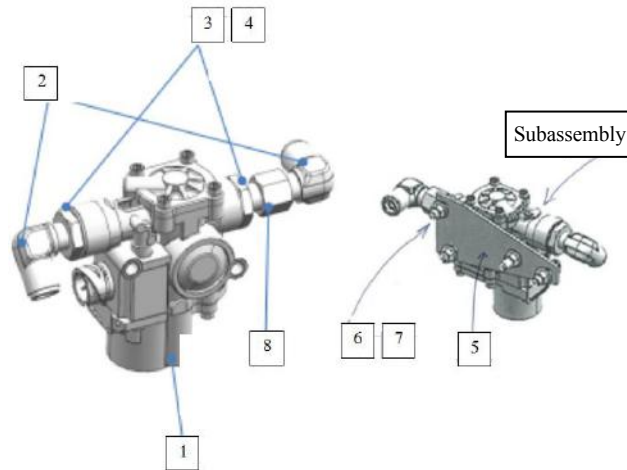

Assembly requirements:

1. Take the transition connector 3, and smear 8-10mm long thread sealant in the longitudinal direction, starting 2-3 pitches from the lowest part of the thread.
2. Put the copper washer 4 into the air pressure regulation valve 1, screw the sealant-applied connector 3 into the air pressure regulation valve 1, and tighten it two or three turns; then, loosen it two or three turns to allow the sealant to be evenly smeared onto the valve body. Tighten the connector 3.
3. Tighten the quick change connector 2 to the transition connector 3 at the air outlet end in the same way.
4. Fix the air pressure regulation valve 1 to the support 5 using the bolt 6 and the nut 7.

Assembly details:

1. Air pressure regulation valve (3203080-912/C)
2. Quick change connector
3. Transition connector (3523214-D17YZ)
4. Copper washer-air pressure regulation valve (3506904-CEH24)
5. Support (3606325-D17YZ)
6. Bolt (Q1840880)
7. Nut (Q32008)
8. Quick-change connector (3523214-D17YZ)

Air pressure regulation valve -Rear (EXZ)

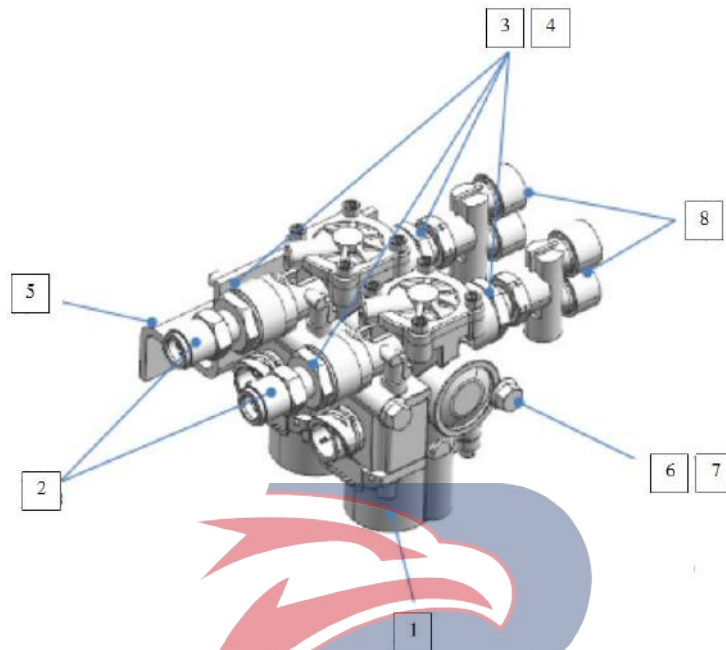

Assembly requirements:

1. Take the transition connector 3, and smear 8-10mm long thread sealant in the longitudinal direction, starting 2-3 pitches from the lowest part of the thread.
2. Put the copper washer 4 into the air pressure regulation valve 1, screw the sealant-applied connector 3 into the air pressure regulation valve 1, and tighten it two or three turns; then, loosen it two or three turns to allow the sealant to be evenly smeared onto the valve body. Tighten the connector 3.
3. Tighten the quick change connector 2 to the transition connector 3 at the air outlet end in the same way.
4. Fix the air pressure regulation valve 1 to the support 5 using the bolt 6 and the nut 7.

Assembly details:

1. Air pressure regulation valve (3203080-912/C)
2. Quick change connector
3. Transition connector (3523214-D17YZ)
4. Copper washer-air pressure regulation valve (3506904-CEH24)
5. Support (3523232-D17YZ)
6. Bolt (Q1840814)
7. Nut (Q32008)
8. Quick-change connector (3518046-D17YZ)

ECM

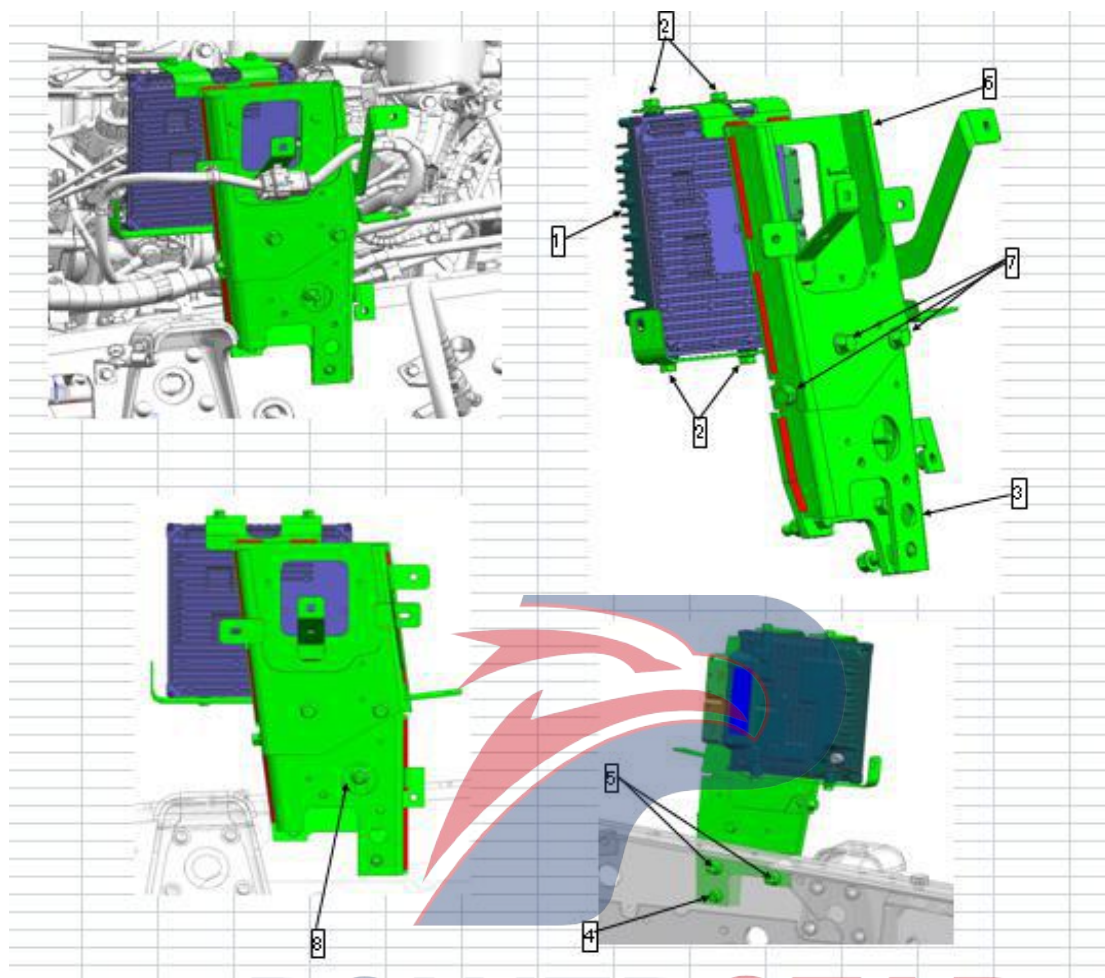

6W	12F	0500A	8974330751	CONTROL UNIT;ENG	6WG1-TCN(420ps)	標準仕様	●
	12F	0500A	8974330781	CONTROL UNIT;ENG	6WG1-TCN(420ps)	コンクリートポンプ	●
	12F	0500A	8974330811	CONTROL UNIT;ENG	6WG1-TCN(420ps)	消防	●
	12F	0500A	8983518961	CONTROL UNIT;ENG	6WG1-TCN(420ps)	危険物	●
	12F	0500A	8974330761	CONTROL UNIT;ENG	6WG1-TCC(460ps)	標準仕様	●
	12F	0500A	8974330791	CONTROL UNIT;ENG	6WG1-TCC(460ps)	コンクリートポンプ	●
	12F	0500A	8974330821	CONTROL UNIT;ENG	6WG1-TCC(460ps)	消防	●
	12F	0500A	8983518971	CONTROL UNIT;ENG	6WG1-TCC(460ps)	危険物	●

Assembly requirements:

1. Assemble ECM with parts (1) (2) (3) (4) (5) (6) (7) (8) as shown in the figure.
2. ECU specifications as shown on the right.

Assembly details:

1. ECU module
2. Bolt (Q1840816)
3. Support (3735131-D17YZ)
4. Bolt (Q1841040(P=1.25))
5. Nut (Q32010T13F2(P=1.25))
6. Support (3735121-D17YZ)
7. Bolt (Q1841020(P=1.25))
8. Nut (Q32010T13F2(P=1.25))

Tightening torque:

- Bolt 2: 24.7N · m(2.5kgf · m)
19.7~29.6N · m(2.0~3.0kgf · m)
- Bolt 4: 47.1N · m(4.8kgf · m)
35.4~58.9N · m(3.6~6kgf · m)
- Nut 5: 47.1N · m(4.8kgf · m)
31.3~52.5N · m(3.2~5.4kgf · m)
- Bolt 7: 47.1N · m(4.8kgf · m)
35.4~58.9N · m(3.6~6kgf · m)
- Nut 8: 42.5N · m(4.3kgf · m)
31.3~52.5N · m(3.2~5.4kgf · m)

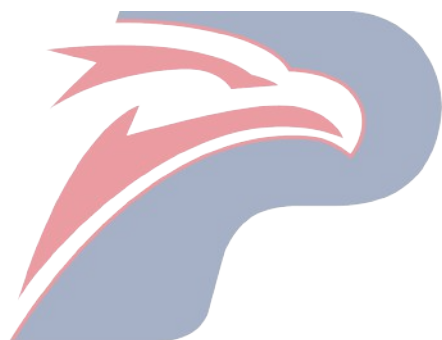

POWERSTAR

Blast pump hard tube assembly

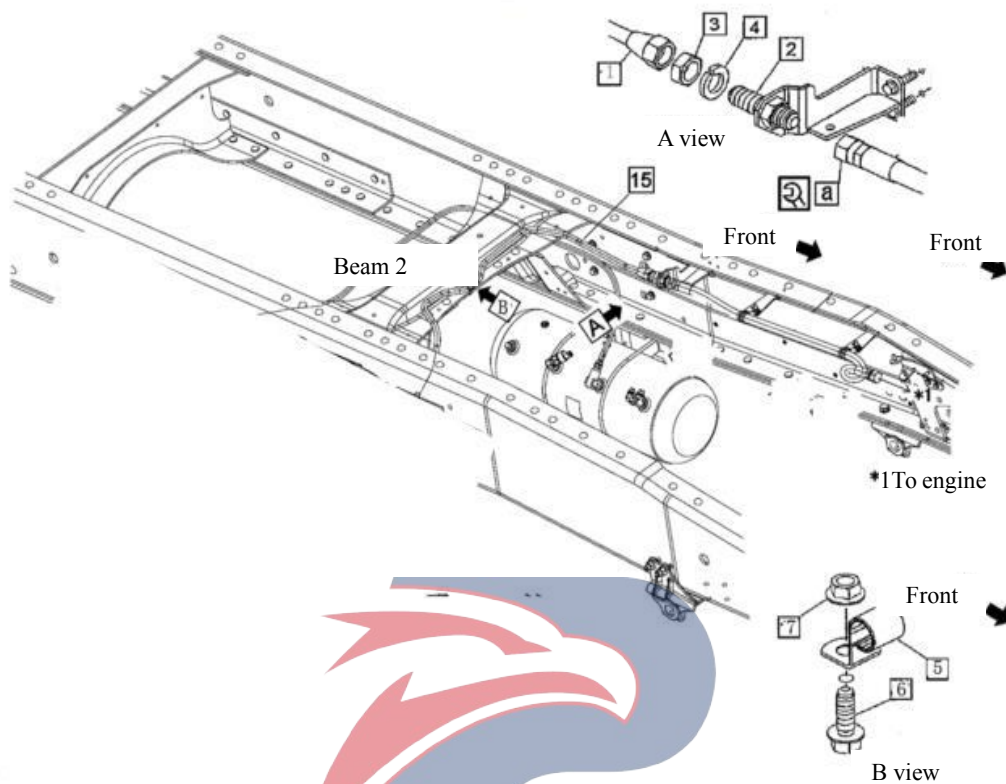

Assembly requirements:

1. Get connector (2) through the bracket hole, and put on the spring washer (4) and nut (3).
2. Tighten the nut (3)
3. Arrange the hard tube assembly (1) as shown on the right. The front end is connected to the blast bump hose and the rear end is connected to the drying tank.
4. Fix the hard tube assembly (1) onto the beam 2 with clip (5), bolt (6) and nut (7) as shown on the right.
5. Tighten the connectors on both ends of the hard tube and the bolt (6).

Assembly details:

1. Hard tube assembly (3506065-D34EZ)
1. Hard tube assembly (3506075-D15EH)
1. Hard tube assembly (3506075-D35EZ)
2. Connector
3. Nut (Q341B22)
4. Spring washer (Q40322)
5. Clip
6. Bolt (Q1840820)
7. Nut (Q32008)

Connecting and fixing of blast pump hose and drying tank

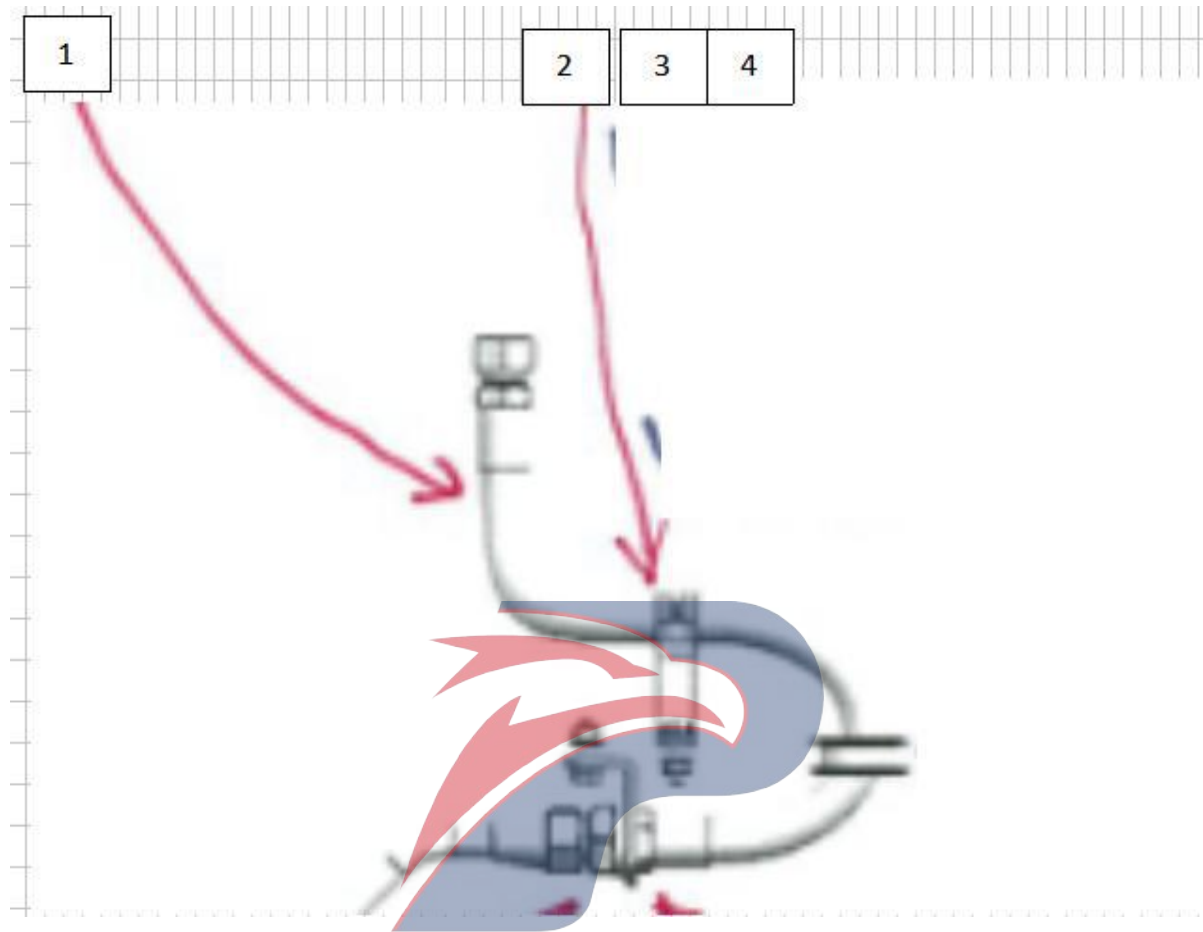

Assembly requirements:

1. As shown in the figure, arrange the pump hose assembly (1) as shown on the right. The front end is connected to the pump hose joint, and the rear end is connected to the drying tank joint.
2. The pump hose assembly is fixed to the frame rail with clip (2), bolt (3) and nut (4) as shown on the right.
3. Tighten the two ends of the pump hose at a torque of 78.4 N.m.
4. Tighten bolt (3).

Assembly details:

1. Hose assembly (3506068-D17YZ)
2. Clip (3506161-D17YZ)
3. Bolt (Q1840825)
3. Bolt (Q1840835)
4. Nut (Q32008)

Blast pump hard tube mounting bracket assembly (6W)

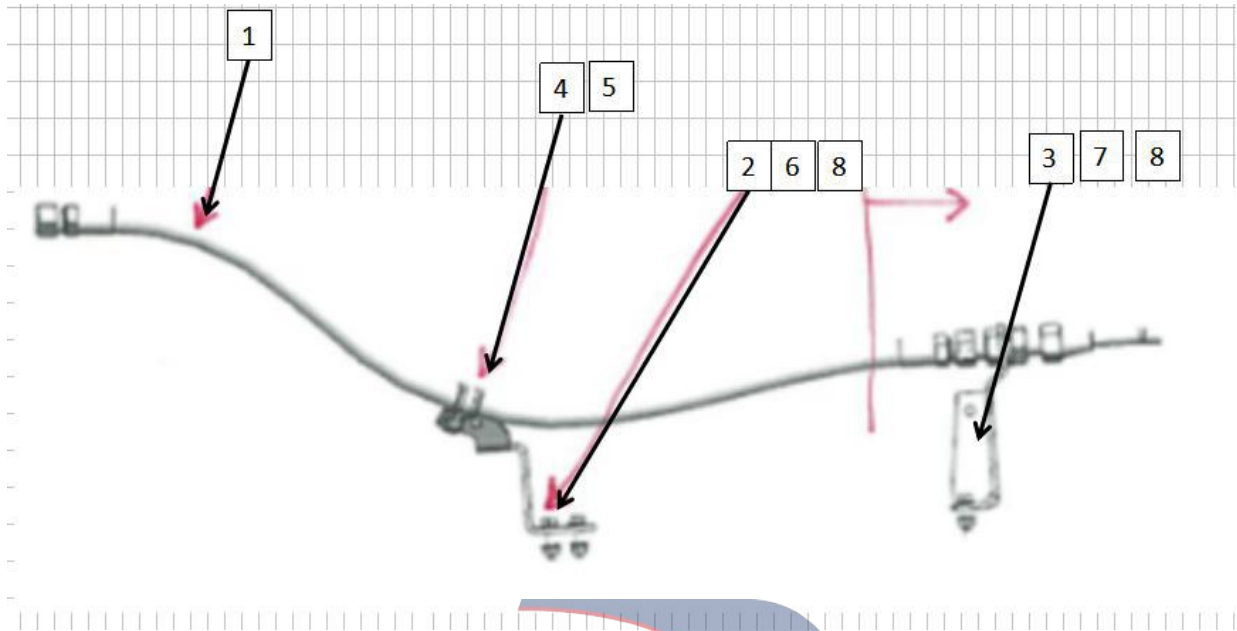

Assembly requirements:

1. Assemble parts (1), (2), (3), (4), (5), (6), (7), and (8) as shown in the figure.

Assembly details:

1. Hose assembly (3506061-D17YZ)
2. Bracket (3506063-D17YZ)
3. Bracket
4. Clip
5. Bolt (Q1840820)
6. Bolt (Q1840830)
7. Bolt (Q1840835)
8. Nut (Q32008)



POWERSTAR

Right front fender assembly

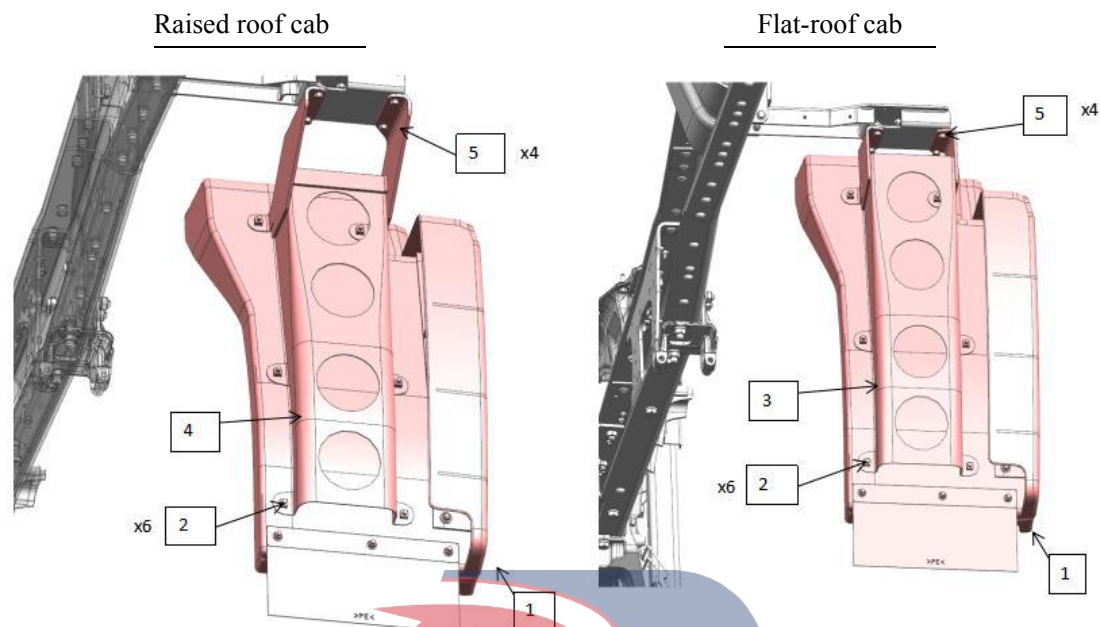

Assembly requirements:

1. Fix the support 3 or 4 into the corresponding holes of the portal frame with the nut (5).
2. Fix the fender assembly 1 with the bolt 2.

Assembly details:

1. Fender assembly (3102180-D17YZ)
2. Bolt (5002711-P301)
3. Support (3102212-D17YZ)
4. Support (3102202-D17YZ)
5. Bolt (Q1841025(P=1.25))

POWERSTAR

Left front fender assembly

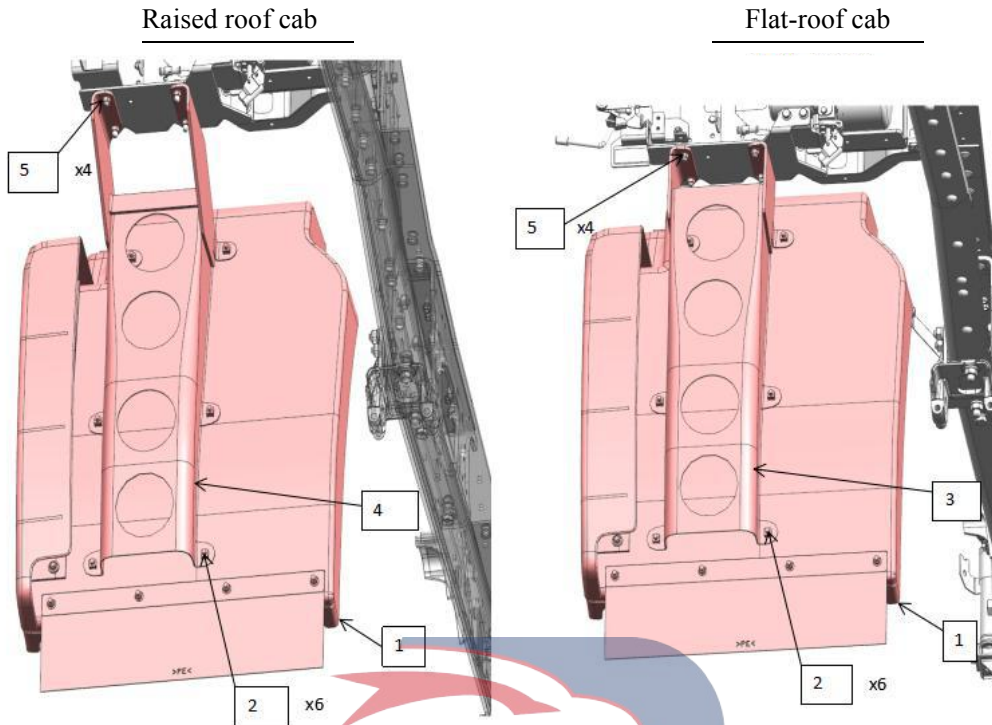

Assembly requirements:

1. Fix the support 3 or 4 into the corresponding holes of the portal frame with the nut (5).
2. Fix the fender assembly 1 with the bolt 2.

Assembly details:

1. Fender assembly (3102170-D17YZ)
2. Bolt (5002711-P301)
3. Support (3102211-D17YZ)
4. Support (3102201-D17YZ)
5. Nut (Q1841025(P=1.25))

POWERSTAR

Fender subassembly on both sides

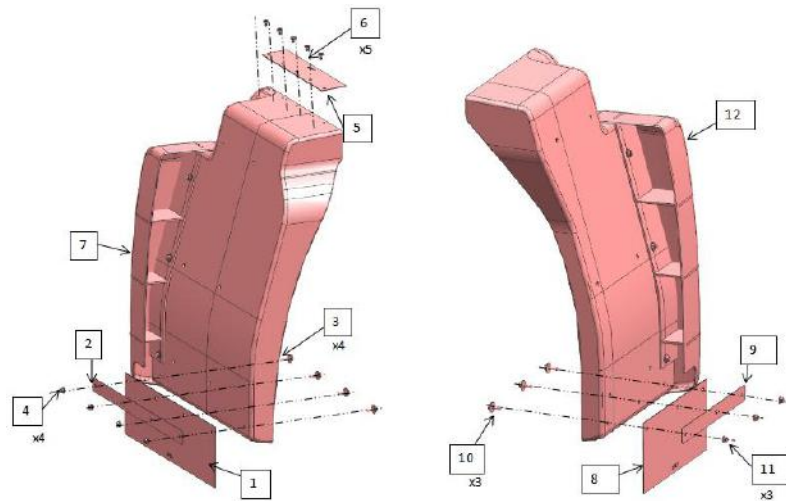

Assembly requirements:

1. Assemble the fenders as shown on the right.

Assembly details:

1. Rubber (3102173-D17YZ)
2. Retainer-rubber (3102174-D17YZ)
3. Bolt 5002711-P301
4. Nut (Q32008)
5. Rubber (3102178-D17YZ)
6. Fastening nail (8405123-117/C)
7. Fender (3102270-D17YZ)
8. Rubber (3102183-D17YZ)
9. Retainer-rubber (3102184-D17YZ)
10. Bolt (5002711-P301)
11. Nut (32008)
12. Fender (3102280-D17YZ)

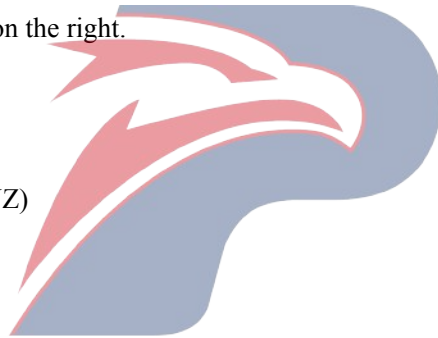

POWERSTAR

Air guide sleeve assembly (standard roof)

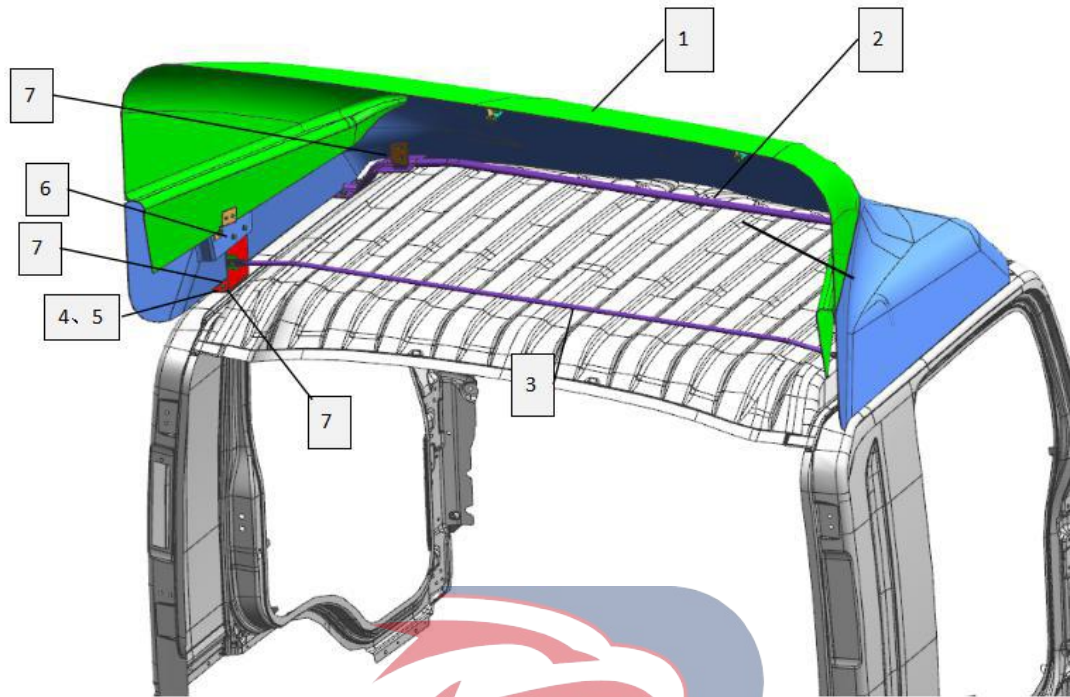

Assembly requirements:

1. Assemble parts (1), (2), (3), (4), (5), (6), and (7) as shown in the right figure.

Assembly details:

1. Roof air guide sleeve assembly (6001110-CEZ24)
2. Front bracket assembly
3. Rear bracket connecting rod
4. Left bracket
5. Right bracket
6. (894331741)
7. Bolt (Q1460825)

POWERSTAR

Hazardous chemical identification lamp assembly (standard roof)

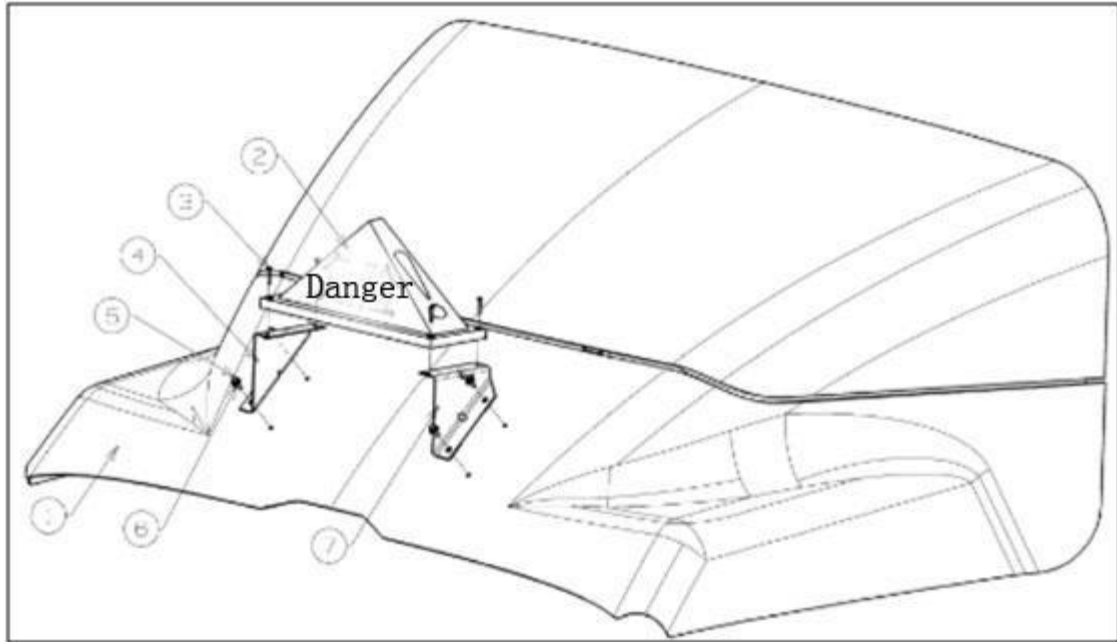

Assembly requirements:

1. Assemble parts (1), (2), (3), (4), (5), (6), and (7) as shown in the right figure.

Assembly details:

1. Air guide sleeve assembly (6001010-D24EZ)
2. Hazardous chemical identification lamp (4219012-D17YZ)
3. Screw (GB/T 819.1 M5X35)
4. Right mounting bracket (4217016-D17YZ)
5. Bolt (Q1460825)
6. Washer (Q40108)
7. Left mounting bracket (4219014-D17YZ)

POWERSTAR

Air guide sleeve assembly (raised roof)

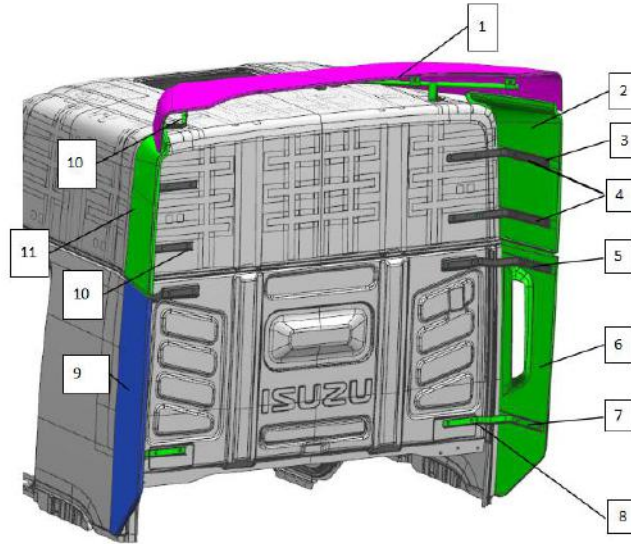

Assembly requirements:

1. Assemble parts (1), (2), (3), (4), (5), (6), (7), (8), (9), (10) and (11) as shown in the right figure.

Assembly details:

1. Roof air guide sleeve (8250110-D17YZ)
2. Upper side of right wing (8250310-D17YZ)
3. Nut (Q32008)
4. Upper bracket on side wing (8250221-D17YZ)
5. Lower bracket on side wing A (8250421-D17YZ)
6. Lower side of right wing (8250310-D17YZ)
7. Lower bracket on side wing B (8250422-D17YZ)
8. Bolt (Q1460820)
9. Lower side of left wing (8250410-D17YZ)
10. Bolt (Q1460825)
11. Upper side of left wing (8250210-D17YZ)

POWERSTAR

Hazardous chemical identification lamp (raised roof)

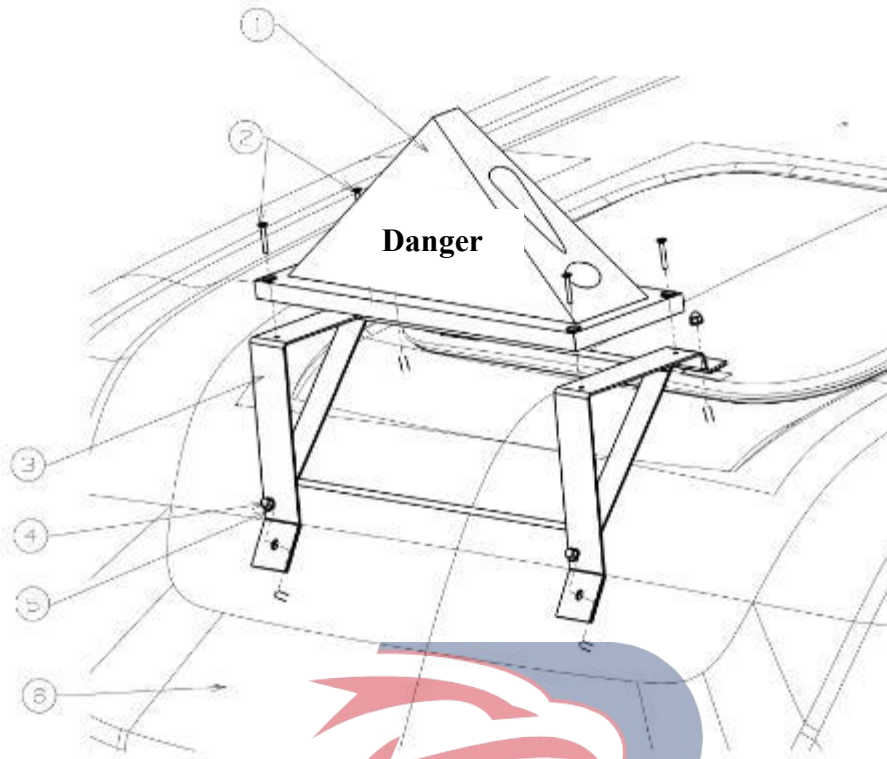

Assembly requirements:

1. Assemble parts (1), (2), (3), (4), (5), and (6) as shown in the right figure.

Assembly details:

1. Hazardous chemical identification lamp (4219012-D17YZ)
2. Screw (GB/T 819.1 M5X35)
3. Mounting bracket (4129016-D17YZ)
4. Nut (8101162-117/C)
5. Washer (Q40108)
6. Roof assembly (5700030-D15YZ)

POWERSTAR

Engine front and rear suspension connection (6W)

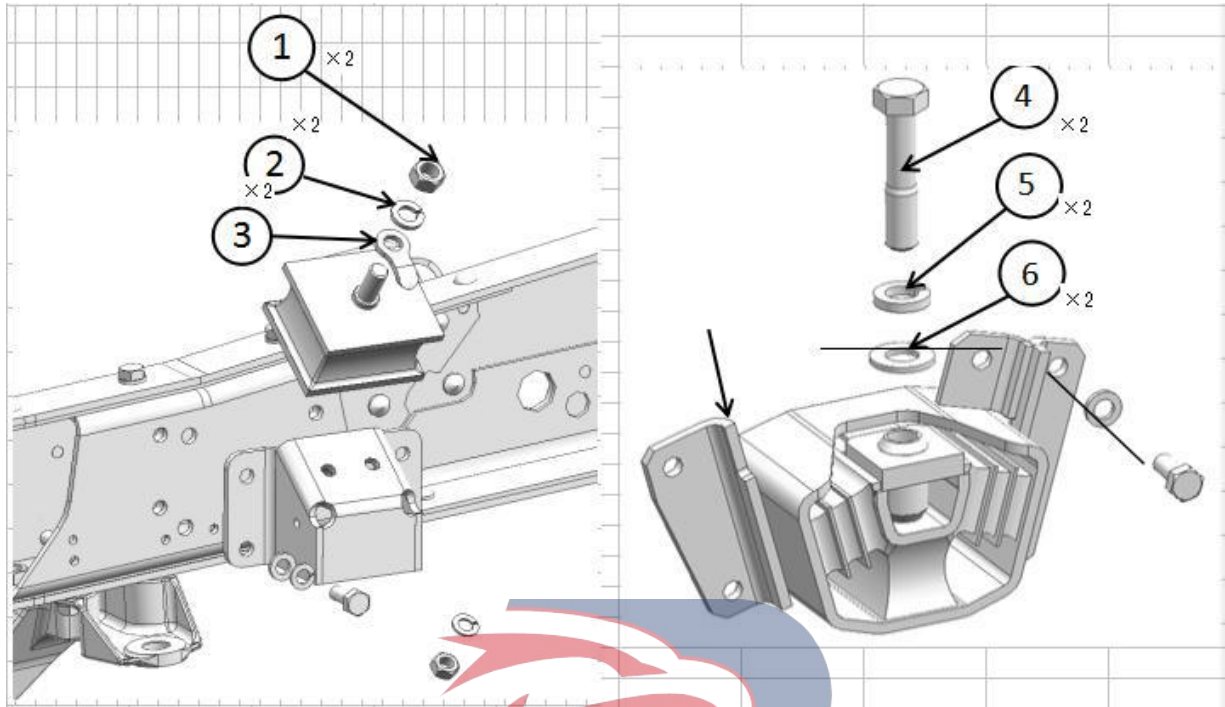

Assembly requirements:

1. Lift up the engine and transmission assembly and drop them.
2. Connect the front end of the engine to the front suspension with nut ①, spring washer ② and flat gasket ③.
3. Connect the rear end of the engine to the rear suspension with bolt ④, spring washer ⑤ and flat gasket ⑥.
4. Tighten nut ① at a torque of $225 \pm 20 \text{ N.m}$
5. Tighten bolt ④ at a torque of $490 \pm 50 \text{ N.m}$.

Assembly details:

1. Nut Q341B18
2. Spring washer Q40118
3. Lock plate 1532290400
4. Bolt 2801304-D17YZ
5. Spring washer Q40522
6. Washer 2801306-D17YZ

Fix upper trachea of the transmission(16 speed)

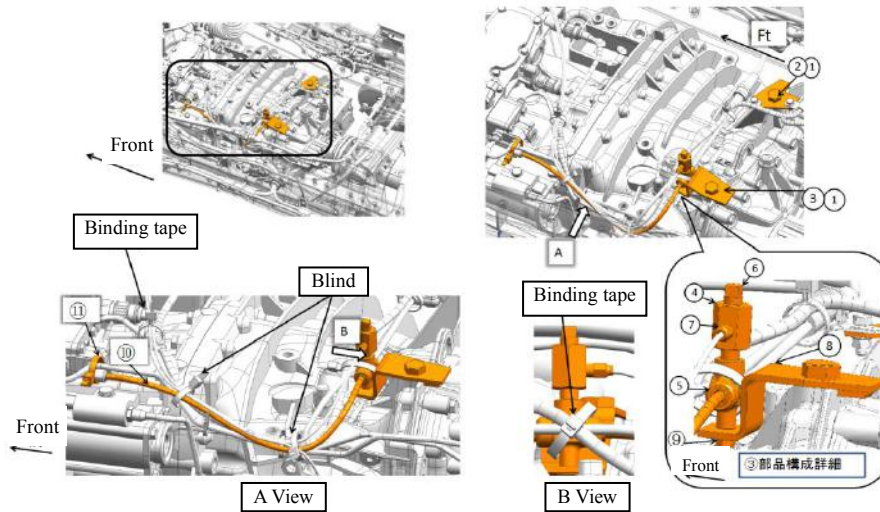

Assembly requirements:

1. Assemble the parts(1)(2)(3)(4)(5)(6)(7)(8)(9)(10)(11)(12) as shown on the right figure.

Assembly details:

1. Bolt (Q151B1630)
2. Support (1703262-D17YZ)
3. Bolt (Q1840820)
4. Connector assembly (1703351-D17YZ)
5. Connector (1703255-D17YZ)
6. Connector
7. End plug (3513115-150)
8. Connector (3506058-D17YZ)
9. Support (1703421-D17YZ)
10. Bolt (Q1840820)
11. Nylon hose (1703052-CEH14)
12. Binding tape

POWERSTAR

Connection of upper part shift zipper of the transmission (6W)



Assembly requirements:

1. Assemble parts (1) to (19) as shown in the right figure.

Assembly details:

1. Shift lever bracket assembly (6W)(1702160-D15EH)
2. Nut (Q32008)
3. Nut (Q32010T13F2(P=1.25))
4. Bolt (Q1840830)
5. Retaining plate (1702231-P301)
6. Nut
7. Connecting rod-gearshift lever (1702161-D17YZ)
8. Nut
9. Nut (1702234-P301)
10. Retaining plate (1702231-P301)
11. Bolt (Q1840830)
12. Support-gearshift cable(1702164-D16YZ)
Support-gearshift cable (6W)(1702165-D17YZ)
13. Bolt (Q1840830)
14. Clip (3724139-D17YZ)
15. Bolt (Q1840820)
16. Nut (Q32008)
17. Binding tape
18. Support (1703274-D17YZ)
19. Nut (Q32012T13F2(P=1.25))

POWERSTAR

Hot and cold water pipes subassembly(6W)

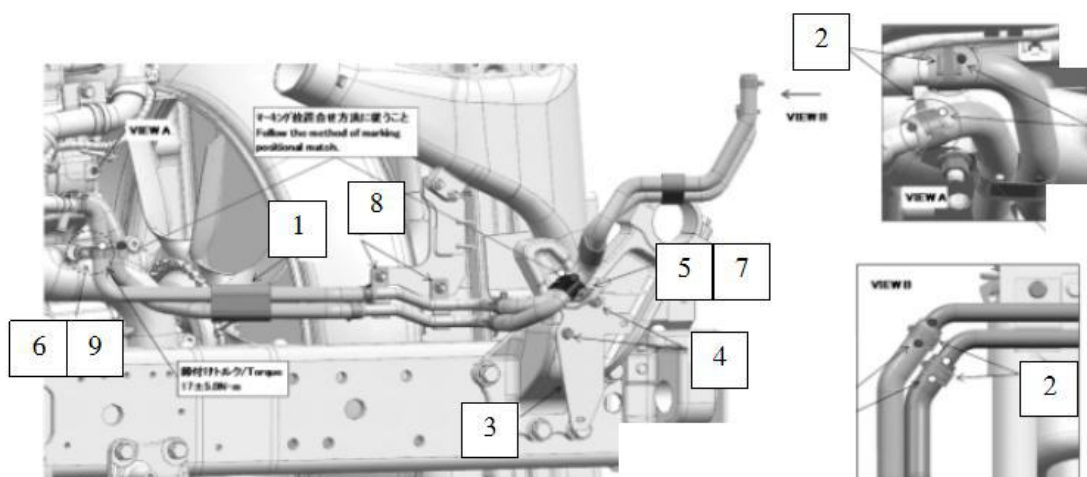

Assembly requirements:

1. Assemble parts (1)(2)(3)(4)(5)(6)(7)(8) and (9) as shown in the right picture.

Assembly details:

1. Warm water pipe (8202407-D15YR)
2. Circumferential clamp
3. Support-warm water pipe (8202408-D17YZ)
4. Bolt (Q1840820)
5. Clip (8101149-117/C)
6. Clip
7. Bolt (Q1840820)
8. Nut (Q32008)
9. Nut (Q32010)

POWERSTAR

The oil dipstick assembly(6W)

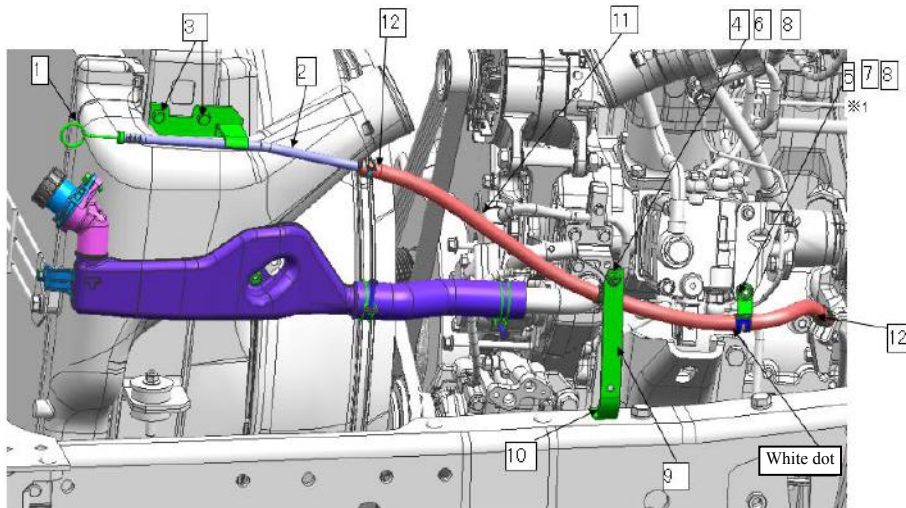

Assembly requirements:

1. Assemble parts (1),(2),(3),(4),(5),(6),(7),(8),(9),(10), as shown in the figure.

Assembly details:

1. Oil dipstick assembly (1018030-D17YZ)
2. Oil dipstick tube assembly (1018020-D17YZ)
3. Bolt (Q1840816)
4. Clip
5. Clip
6. Bolt (Q1840820)
7. Washer (Q40208)
8. Nut (Q32008)
9. Bracket (1109312-D15EH)
10. Bolt (Q1840835)
11. Hose assembly (1018050-D17YZ)
12. Hoop

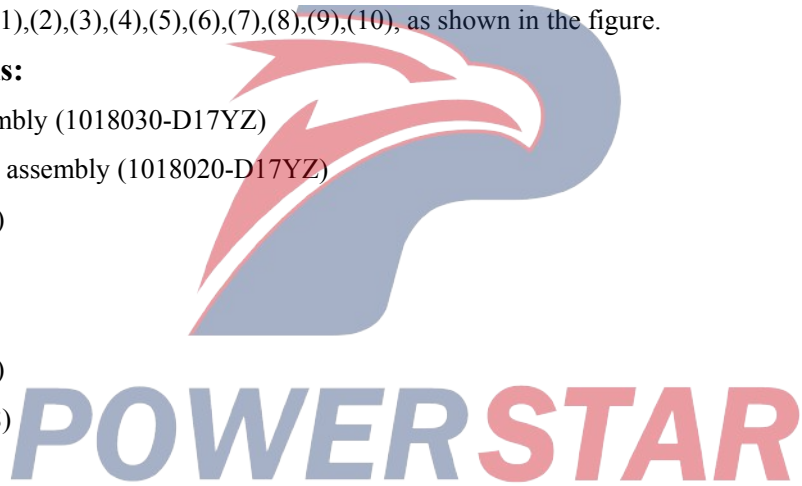

Oil filter assembly (6W)

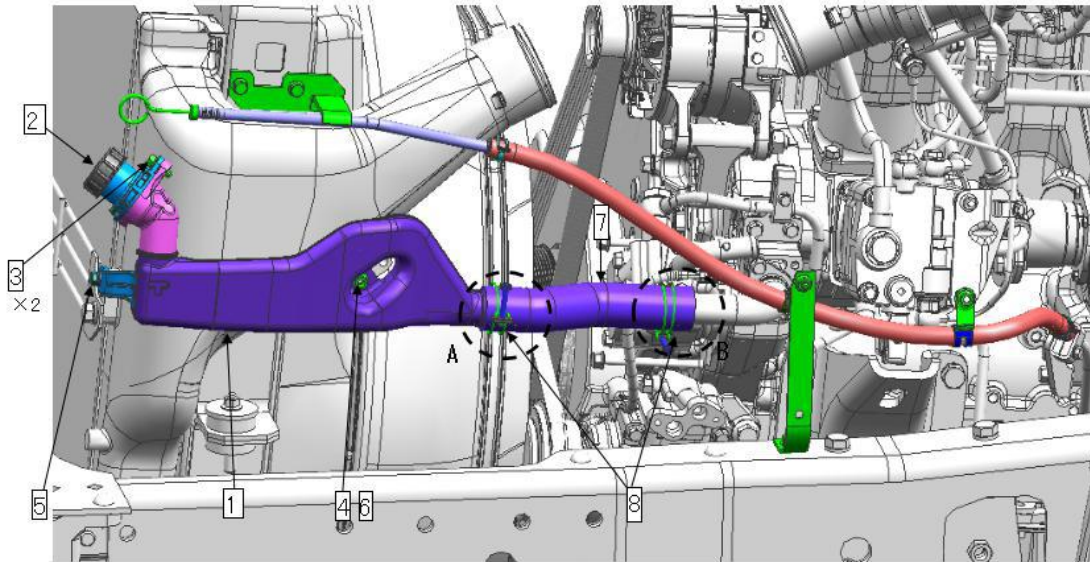

Assembly requirements:

1. Assemble parts (1), (2),(3),(4),(5),(6),(7) and (8) as shown in the figure.

Assembly details:

1. Filter (1109251-D17YZ)
2. Filter assembly (1109255-D17YZ)
3. Bolt (Q1840820)
4. Bolt (Q1840835)
5. Bolt (8101143-117/C)
6. Nut (Q32008)
7. Oil pipe assembly (1109258-D17YZ)
8. Clip (8202539-D17YZ)

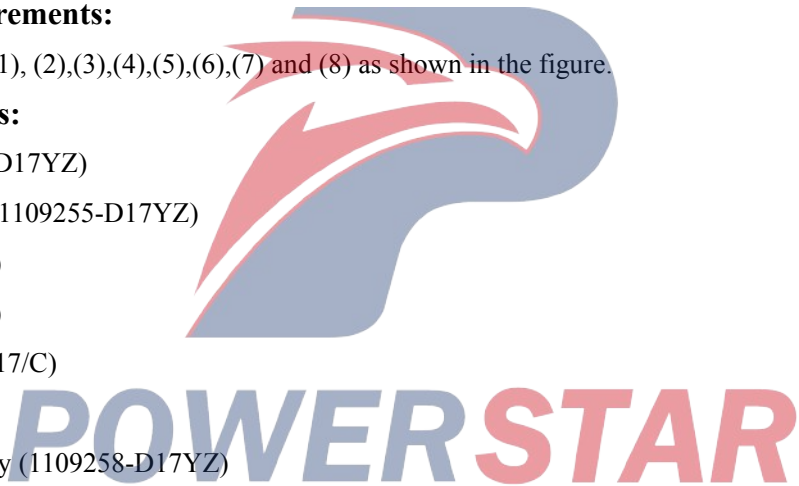

The high and low pressure pipe connection of the air-conditioner in front cap

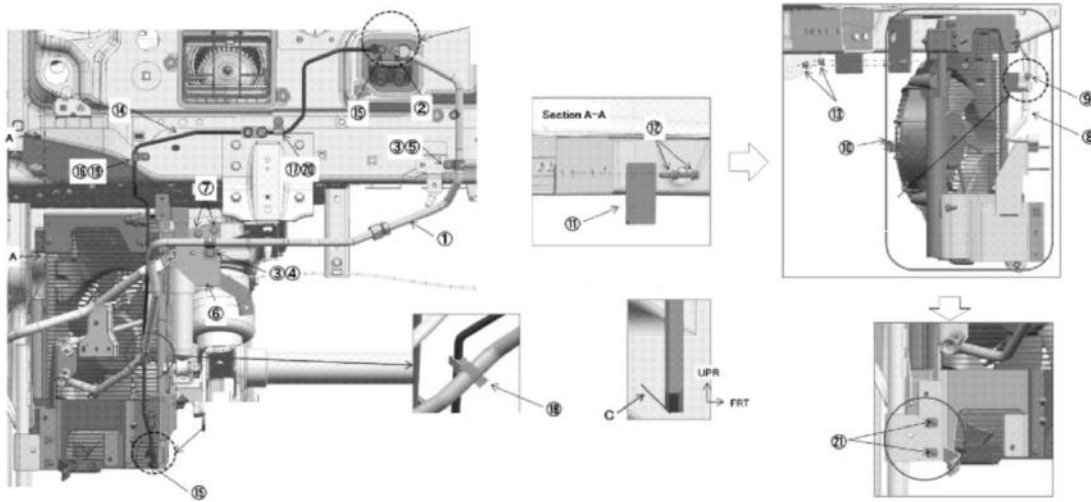

Assembly requirements:

1. Smear the compressor oil evenly with brush on the seal ring at the low pressure pipe connection.
2. Manually screw the low pressure pipe into the low pressure pipe port of the evaporator (as the figure shows).
3. Pull the low pressure pipe nut at a torque of $5.4 \pm 1\text{N.m}$.
4. Smear the compressor oil evenly with brush on the seal ring at the high pressure pipe connection.
5. Manually screw the low pressure pipe into the high pressure pipe port of the evaporator (as the figure shows).
6. Pull the high pressure tube nut at a torque of $5.4 \pm 1\text{N.m}$.

Assembly details:

1. Low-pressure pipe assembly – evaporator to compressor (8100510-D17YZ)
2. Bolt (Q1840625)
3. Clip (3724555-850)
4. Bolt (Q1840820)
5. Hex flange nut (Q32008)
6. Bracket assembly--cooling line (8100513-D17YZ)
7. Bolt (Q1840820)
8. Low-pressure pipe assembly – evaporator to compressor (8100520-D17YZ)
9. Bolt (Q1840625)
10. Condenser assembly - air conditioner (8100610-D17YZ)
11. Bracket assembly - condenser (8100620-D17YZ)
12. Bolt (Q1840820)
13. Hex flange nut (Q32008)
14. Low-pressure pipe assembly – evaporator to compressor (8100530-D17YZ)
15. Bolt (Q1840625)
16. Clip (1703012-D17YZ)

17. Clip

18. Clip (1703013-D17YZ)

19. Bolt (Q1840616)

20. Bolt (Q1840820)

21. Bolt (Q1840820)

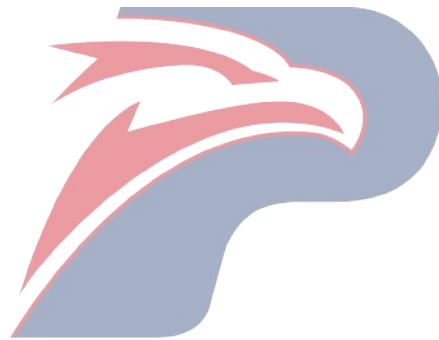

POWERSTAR

The connection and fixzation of cold and warm water pipe in front cap

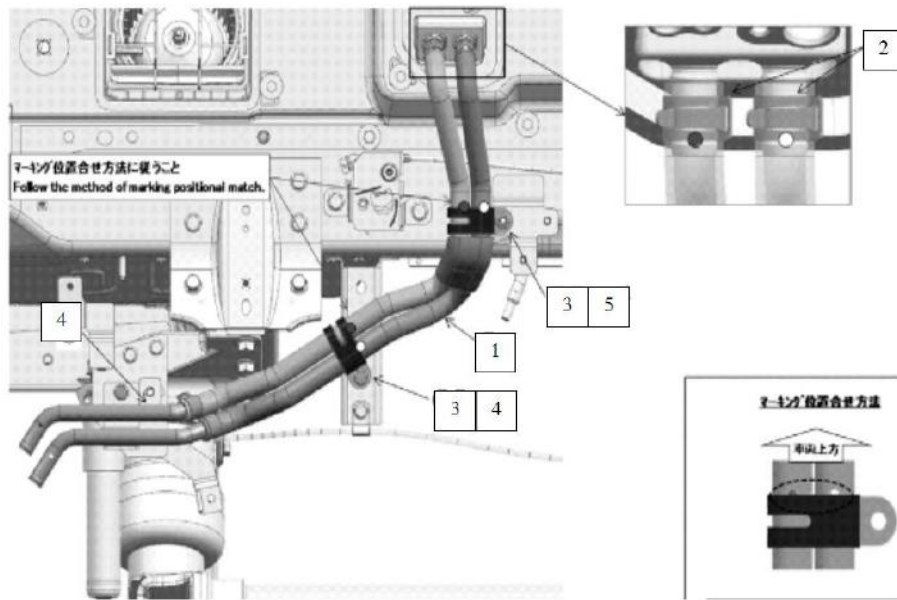

Assembly requirements:

1. Assemble the pipe clip (2) in the warm and cold water pipe (1) at the marked location.
2. As shown in the figure,insert the cold and warm water pipe in place, and fix the pipe clip (2) in turn in the position marked white
3. Assemble the clip (3) in the warm water pipe in the position marked white of the cold and warm water pipe.
4. Take the bolt (4) and nut (5) set in the clip (3) , snap into the mounting hole shown in the figure in the cab.
5. Fasten the bolt (4)and nut (5) from top to bottom.

Assembly details:

- 1.Radiator intake water hose (1018032-D17YZ)
2. Pipe clamp
- 3.Pipe clamp (8101149-117/C)
4. Bolt (Q1840820)
5. Nut (Q32008)

POWERSTAR

Air conditioner high and low pressure pipe assembly (6W)

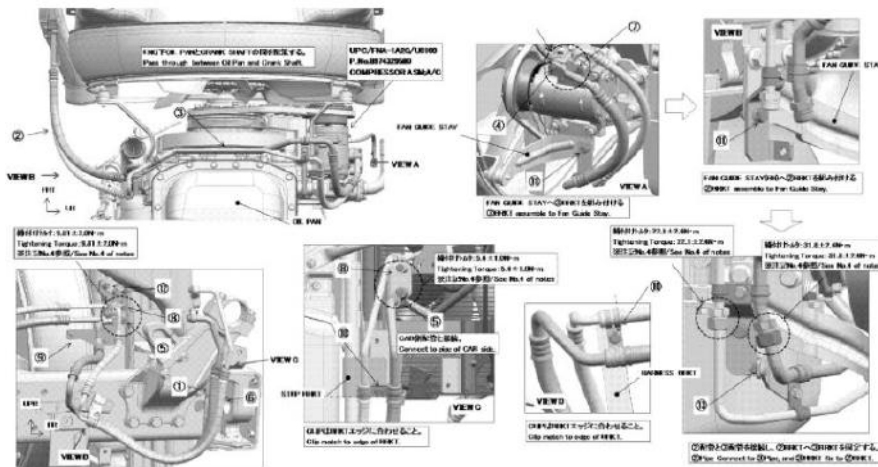

Assembly requirements:

1. Assemble parts (1)(2)(3)(4)(5)(6)(7)(8)(9)(10)(11) and (12) as shown in the right figure.

Assembly details:

1. Hose (8202505-D17YZ)
2. Hose (8202503-D17YZ)
3. Hose (8202504-D17YZ)
4. Bolt (Q1840625)
5. Hex flange nut (Q32006)
6. Hose (8202502-D17YZ)
7. Bolt (Q1840625)
8. Hex flange nut (Q32006)
9. Bracket assembly--cooling line (8202510-D17YZ)
10. Bolt (Q1840820)
11. Bolt (Q1841025)
12. Hex flange nut (Q32008)



Clutch sub-pump conversion adapter subassembly

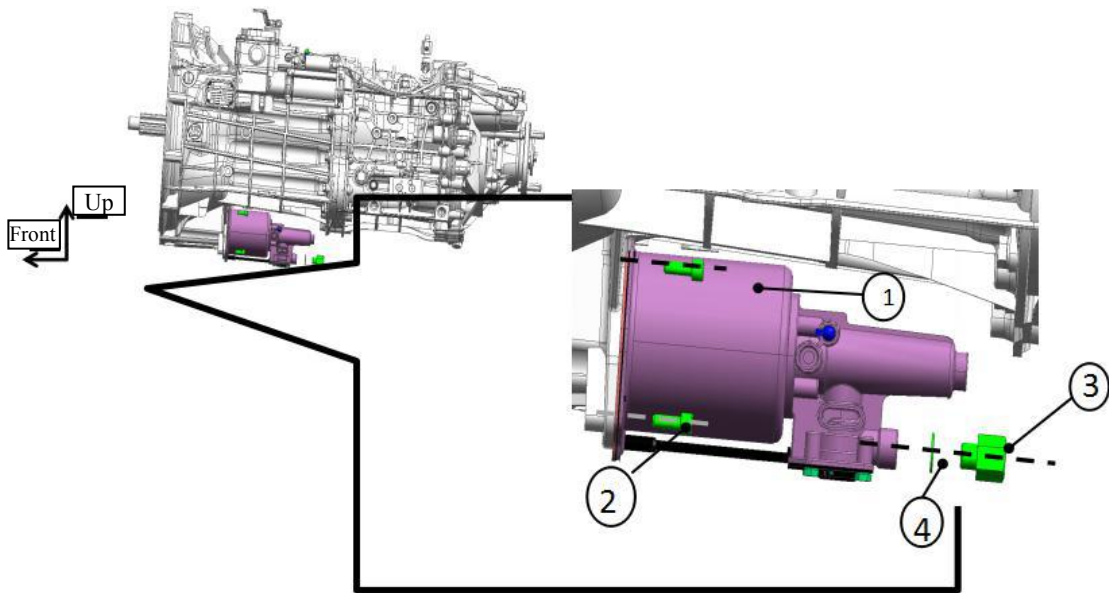

Assembly requirements:

1. Assemble parts (1), (2), (3),(4) as shown in the figure.

Assembly details:

1. Clutch sub-pump (1604020-D17YZ)
2. Bolt (Q1840820)
3. Conversion adapter (1604031-D17YZ)
4. Gasket (1604039-D17YZ)

POWERSTAR

Sieve screen assembly assembly

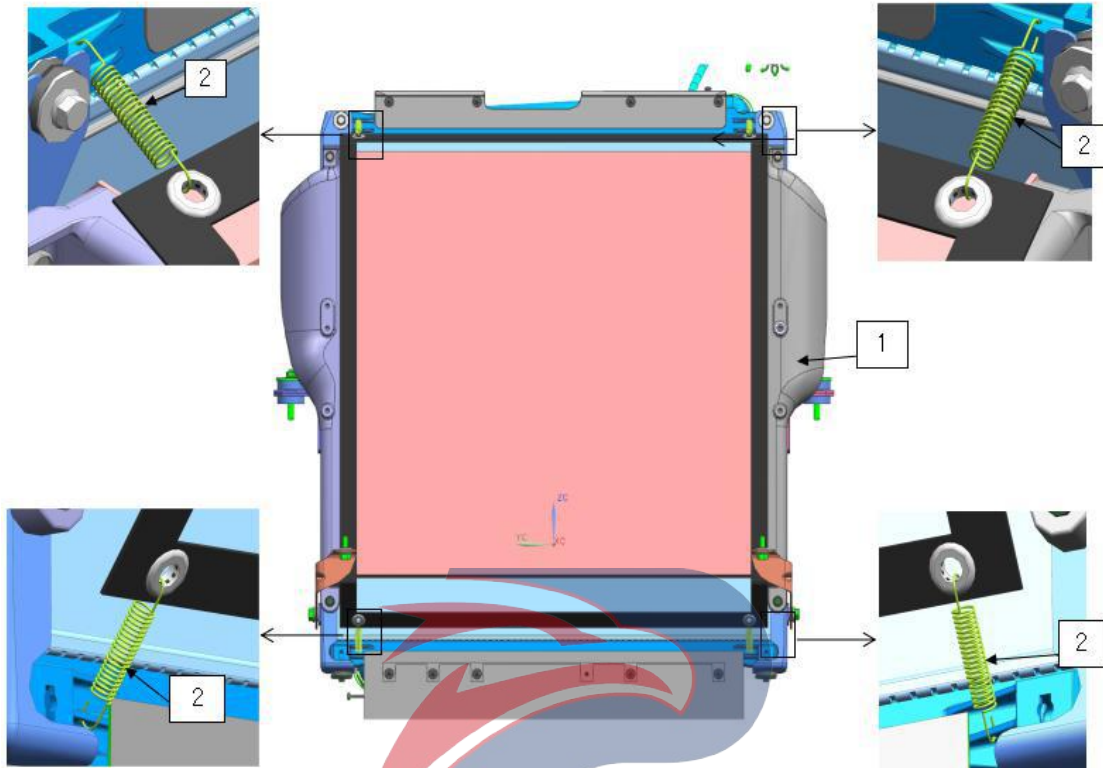

Assembly requirements:

1. Assemble parts (1), (2) as shown in the figure.

Assembly details:

1. Sieve screen assembly (1310021-D17YZ)
2. Return position spring (1310022-D17YZ)

POWERSTAR

Tank and sub-tank hose assembly

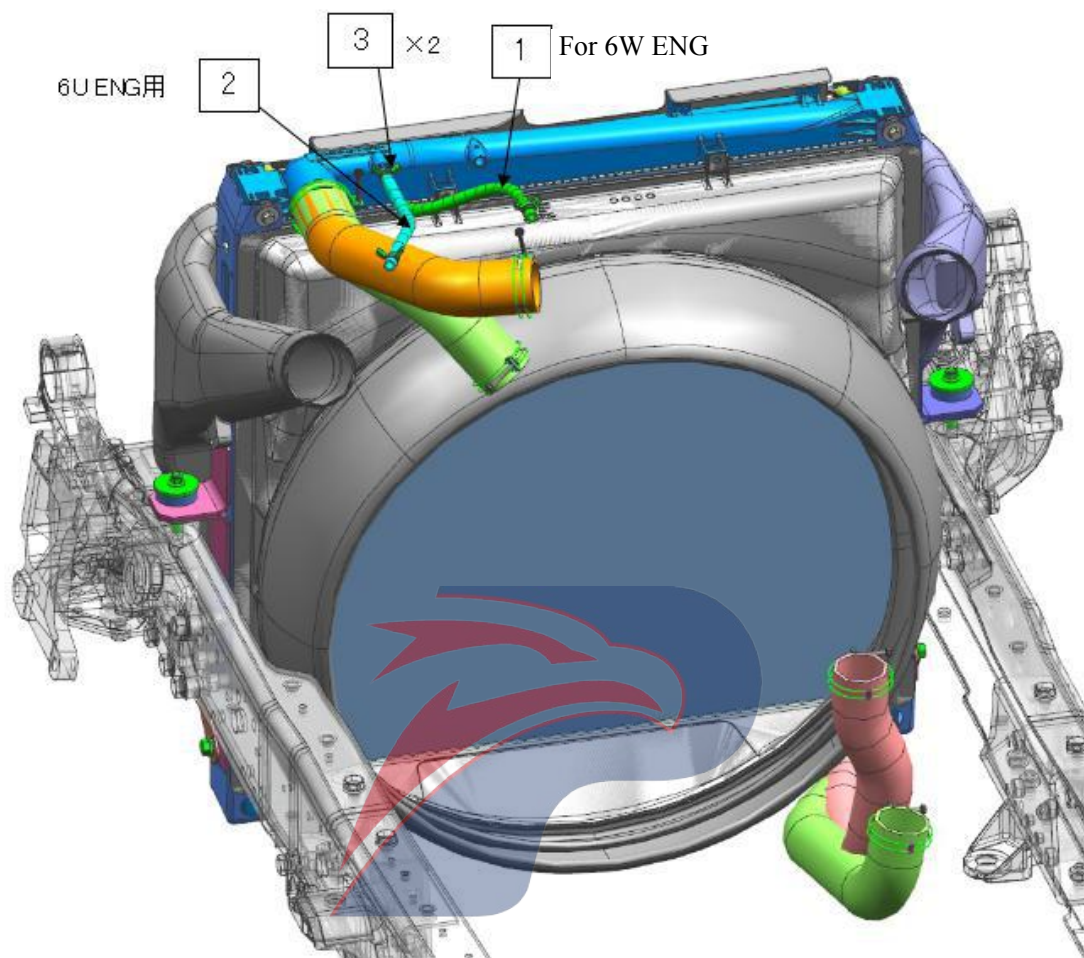

Assembly requirements:

1. Assemble parts (1), (2), and (3) as shown in the figure.

Assembly details:

1. Hose (1301025-D17YZ)
2. Hose
3. Hoop (1104102-117/C)

Tank grille protection assembly

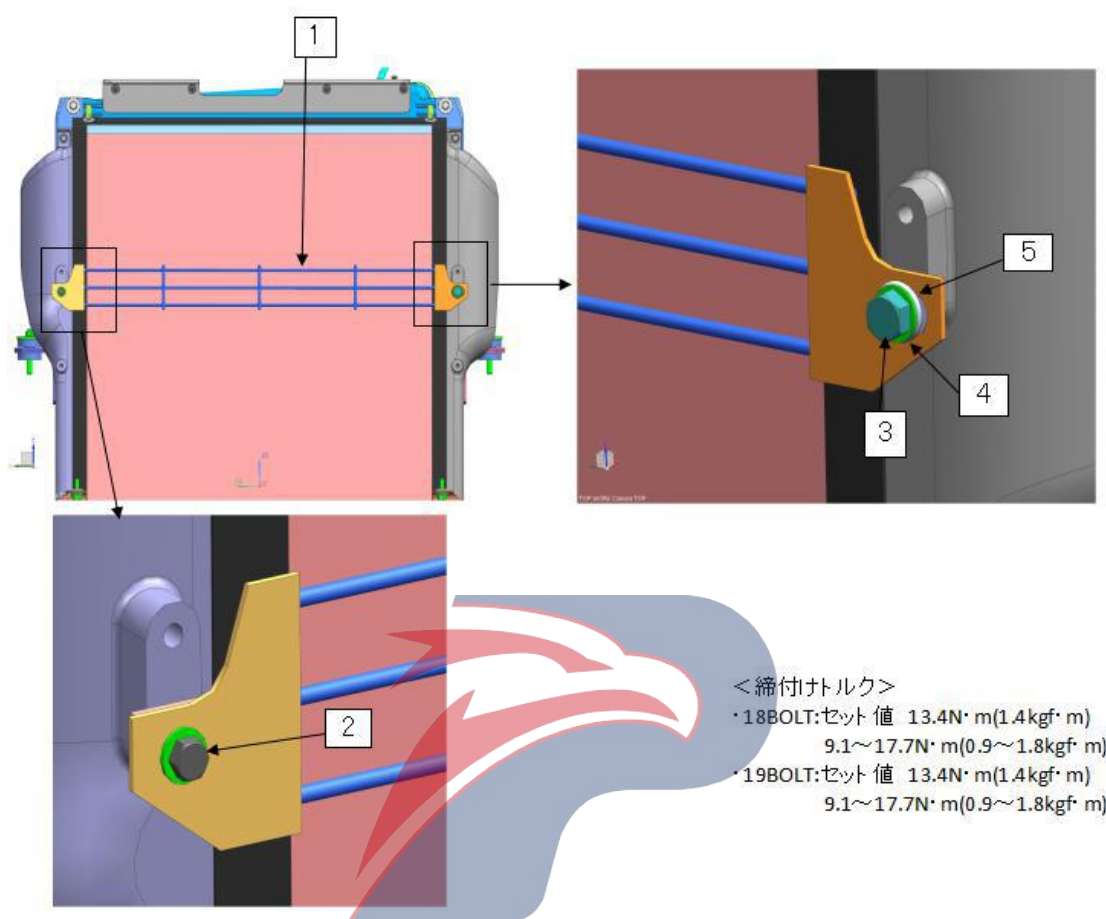

Assembly requirements:

1. Assemble parts (1), (2), (3), (4) and (5) as shown in the figure.

Assembly details:

1. Tank grille protection (1310031-D17YZ)
2. Bolt (1310032-D17YZ)
3. Assembly bolt (1310033-D17YZ)
4. Washer (1310034-D17YZ)
5. Rubber bushing (1301025-117/C)

POWERSTAR

Up and down water pipe assembly in the water tank

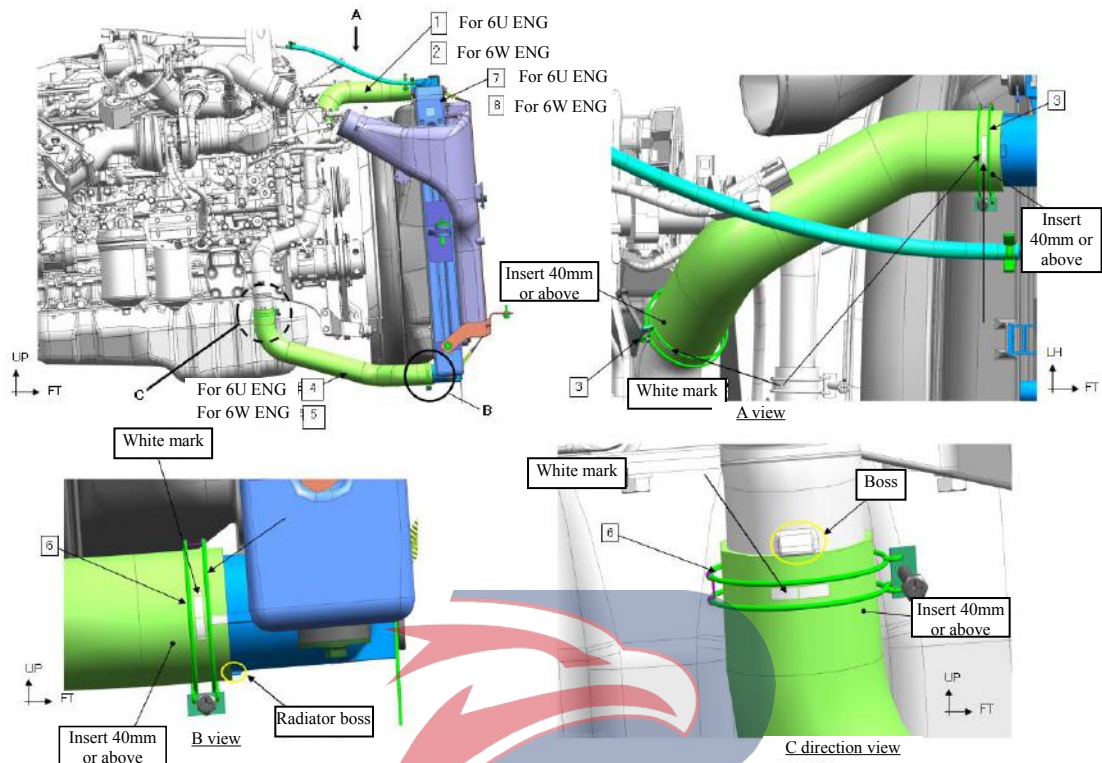

Assembly requirements:

1. Assemble parts (1)(2)(3)(4)(5)(6)(7) and (8) as shown in the figure.

Assembly details:

1. Hose assembly
2. Hose assembly (6W)(1018132-D17YZ)
3. Circumferential clamp (1018033-D17YZ)
4. Hose assembly
5. Hose assembly (6W)(1018034-D17YZ)
6. Circumferential clamp (1018033-D17YZ)
7. Radiator and intercooler assembly (1301010-D15YR)
8. Radiator and intercooler assembly (6W)(1301010-D17YZ)

POWERSTAR

The around rubber pipe of Intercooler of water tank assembly

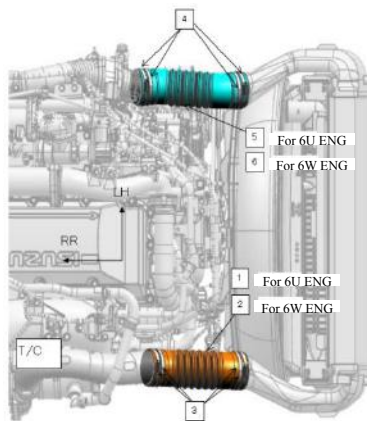

Assembly requirements:

1. As shown in the figure, set the hoop (3) on both ends of the rubber hose (1) or (2).(2 pieces for each)
2. As shown in the figure, insert one end of the rubber hose (1) or (2) into the water tank connector and the other end into the engine connector.
3. As shown in the figure, fasten the hoop (3) at a distance of 5mm away from the hose port.
4. As shown in the figure, set the hoop (4) on both ends of the rubber hose (5) or (6).(2 pieces for each).
5. As shown in the figure, insert one end of the rubber hose (5) or (6) into the water tank connector and the other end into the engine connector.
3. As shown in the figure, fasten the hoop (4) at a distance of 5mm away from the hose port.

Assembly details:

1. Hose
2. Hose (8982582290)
3. Circumferential clamp
4. Circumferential clamp
5. Hose (6W)
6. Hose (8982038940)

POWERSTAR

Drying tank sub-assembly

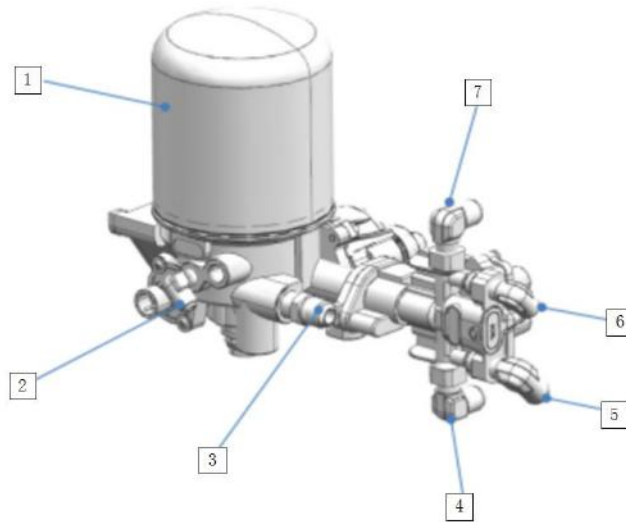

Assembly requirements:

1. Fetch connectors (2), (3), (4), (5), (6) and (7), and smear 8-10mm long Loctite 575# thread sealant onto 2~3 threads longitudinally from the lowest thread.
2. Align the valve (1) with these sealant-applied connectors (2), (3), (4), (5), (6) and (7) and tighten them by 2~3 turns, then loosen them by 2~3 turns, so that the sealant can be evenly applied to the valve.
3. Tighten the connectors (2), (3), (4), (5), (6) and (7).

Assembly details:

1. Dryer assembly
2. Connector
3. Connector
4. Connector
5. Connector
6. Connector
7. Connector



POWERSTAR

Trailer valve sub-assembly (EXR)

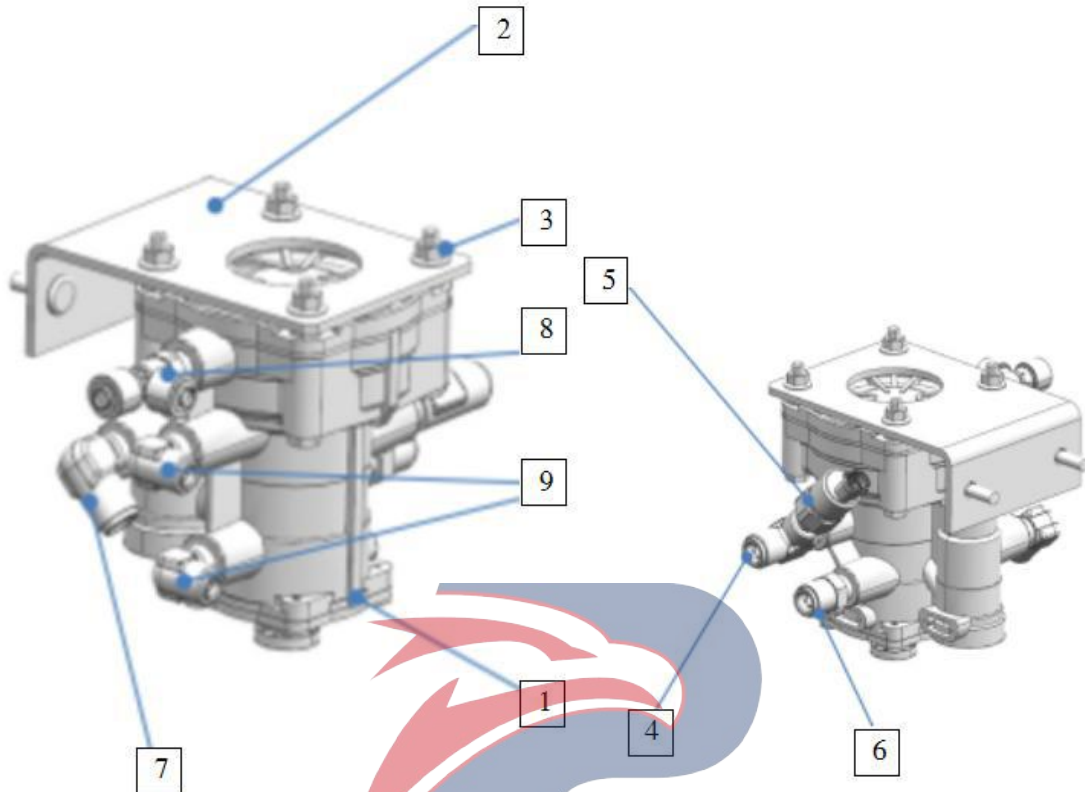

Assembly requirements:

1. Take the connector 4, and smear 8-10mm long thread sealant in the longitudinal direction, starting 2-3 pitches from the lowest part of the thread.
2. Align the sealant-applied connector 4 into the trailer valve and tighten them by 2-3 turns; then loosen it by 2-3 turns so as to allow the sealant to be evenly smeared on the trailer valve body.
3. As shown in the figure, tighten the connector 4. The tightening angle shall be appropriate.
4. Use the same method to fasten the connectors 5 - 9 to the trailer body.
5. Fix the support 2 to the trailer valve 1 using the nut 3.

Assembly details:

1. Trailer valve
2. Support (3606324-D17YZ)
3. Nut (Q32008)
4. Connector (3506423-D17YZ)
5. Pressure switch
6. Connector
7. Connector
8. Connector (8100673-D17YZ)
9. Connector

Trailer valve sub-assembly (EXZ)

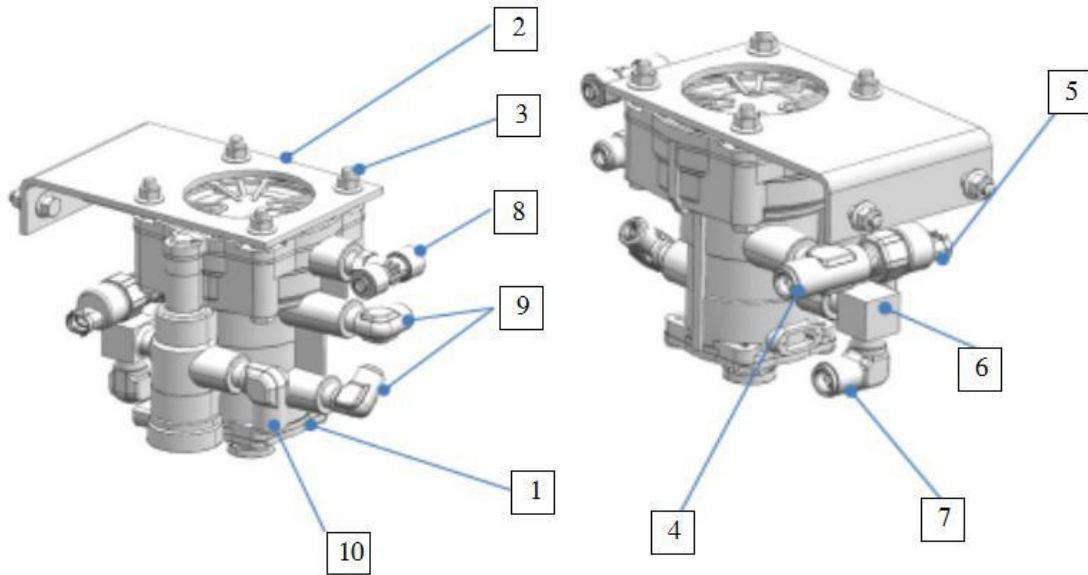

Assembly requirements:

1. Take the connector 4, and smear 8-10mm long thread sealant in the longitudinal direction, starting 2-3 pitches from the lowest part of the thread.
2. Align the sealant-applied connector 4 into the trailer valve and tighten them by 2-3 turns; then loosen it by 2-3 turns so as to allow the sealant to be evenly smeared on the trailer valve body.
3. As shown in the figure, tighten the connector 4. The tightening angle shall be appropriate.
4. Use the same method to fasten the connector 5 - 10 to the trailer body.
5. Fix the support 2 to the trailer valve 1 using the nut 3.

Assembly details:

1. Trailer valve
2. Support
3. Nut (Q32008)
4. Connector
5. Pressure switch
6. Connector
7. Connector
8. Connector (3549102-D17YZ)
9. Connector (8100673-D17YZ)
10. Connector

POWERSTAR

Rear relay valve sub-assembly (EXR)

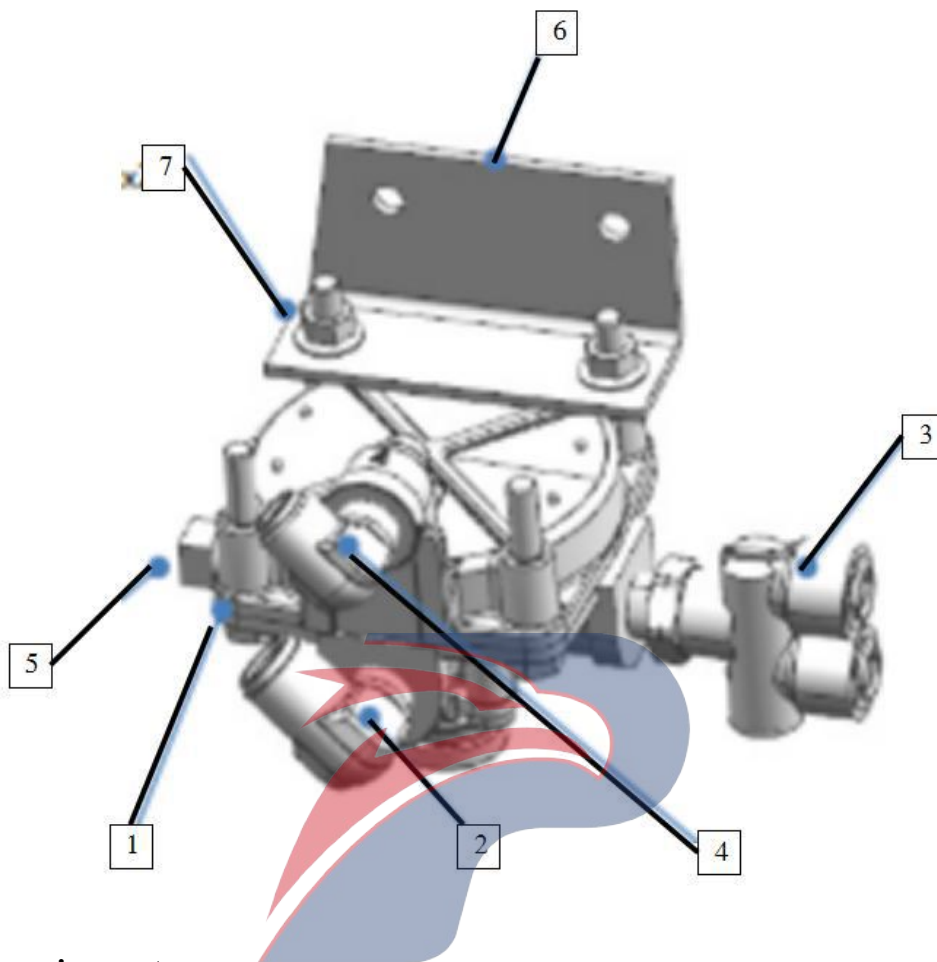

Assembly requirements:

1. Take the connectors (2), (3), (4), (5), and smear 8-10mm long Loctite 575# thread sealant in the longitudinal direction, starting 2-3 pitches from the lowest part of the thread.
2. Align the sealant-applied connectors (2), (3), (4), and (5) with the valve (1), tighten them by 2-3 turns, and then loosen them by 2-3 turns so as to allow the sealant to be evenly smeared on the valve.
3. Tighten the connectors (2), (3), (4) and (5).
4. As shown in the figure, place the support (6) into the assembly hole shown in the relay valve (1) and put on the nut (7).
5. Tighten the nut (7)

Assembly details:

1. Relay valve
2. Connector
3. Connector (3518046-D17YZ)
4. Connector
5. Plug (3513113-117/C)
6. Support (3518039-D15YZ)
7. Nut (Q32008)

Rear relay valve sub-assembly (EXZ)

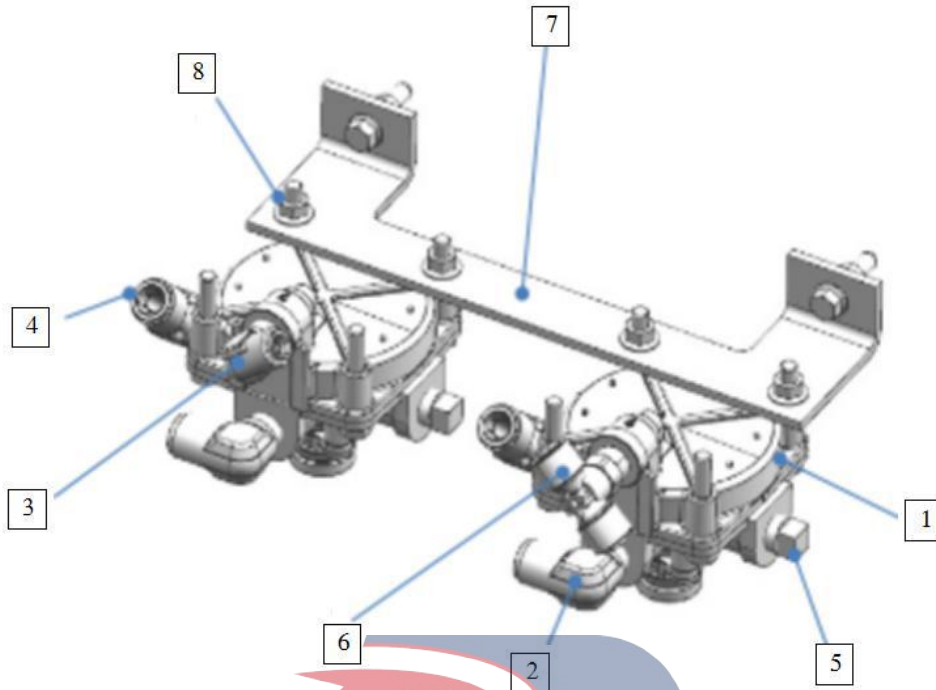

Assembly requirements:

1. Take the connectors (2), (3), (4), (5), (6), and smear 8-10mm long Loctite 575# thread sealant in the longitudinal direction, starting 2-3 pitches from the lowest part of the thread.
2. Align the sealant-applied connectors (2), (3), (4), (5), and (6) with the valve (1), tighten them by 2-3 turns, and then loosen them by 2-3 turns so as to allow the sealant to be evenly smeared on the valve.
3. Tighten the connectors (2), (3), (4), (5), and (6).
4. As shown in the figure, place the support (7) into the assembly hole shown in the relay valve (1), and put on the nut (8).
5. Tighten the nut (8).

Assembly details:

1. Relay valve
2. Connector
3. Connector
4. Connector
5. Plug (3513113-117/C)
6. Connector (3549102-D17YZ)
7. Support (3606322-D17YZ)
8. Nut (Q32008)

POWERSTAR

Rear relay valve sub-assembly

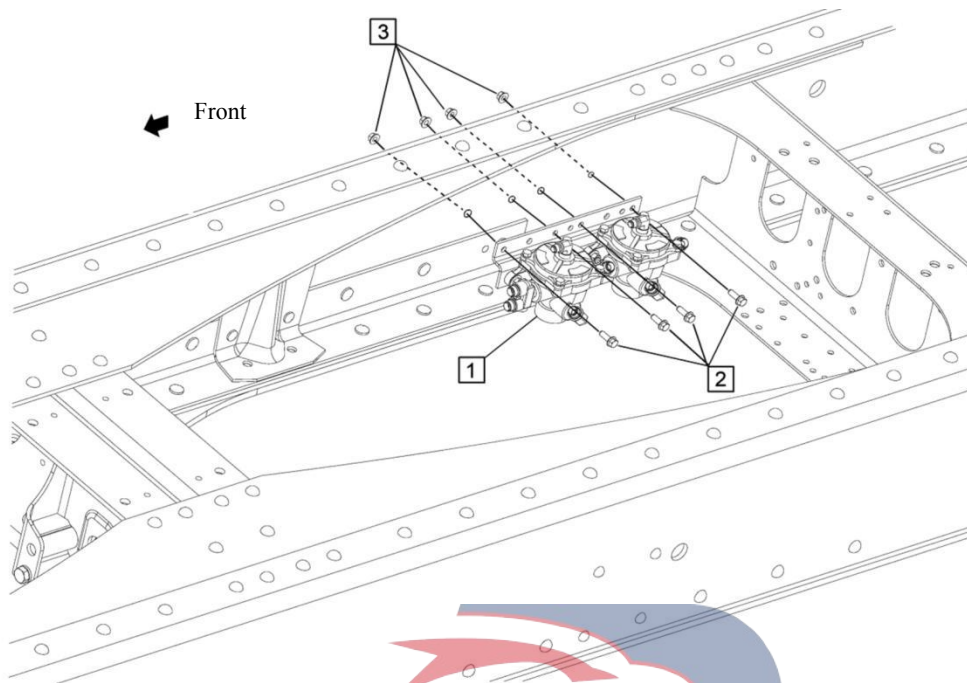

Assembly requirements:

1. As shown, take the valve assembly (1) and bolt (2) through the left hole of the valve assembly (1), and then through the corresponding hole on the frame, and then insert the nut (3).
2. Tighten the nut (3) successively.

Assembly details:

1. Relay valve (8974339200)
2. Bolt (Q1840825)
3. Nut (Q32008)



POWERSTAR

Rear parking valve sub-assembly (EXR)

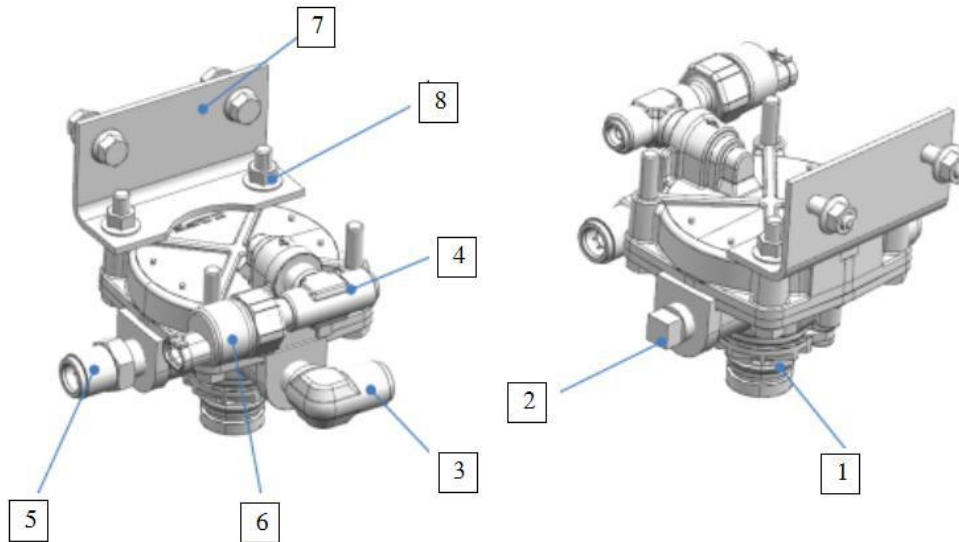

Assembly requirements:

1. Take the connectors (2), (3), (4), (5), and (6), and smear 8-10mm long Loctite 575# thread sealant in the longitudinal direction, starting 2-3 pitches from the lowest part of the thread.
2. Align the sealant-applied connectors (2), (3), (4), (5), and (6) with the valve (1), tighten them by 2-3 turns, and then loosen them by 2-3 turns so as to allow the sealant to be evenly smeared on the valve.
3. Tighten the connectors (2), (3), (4), (5), and (6).
4. As shown in the figure, place the support (7) into the assembly hole shown in the relay valve (1), and put on the nut (8).
5. Tighten the nut (8)

Assembly details:

1. Relay valve
2. Plug (3513113-117/C)
3. Connector
4. Connector (3518046-CEZ14)
5. Connector
6. Switch assembly
7. Support
8. Nut (Q32008)

POWERSTAR

Rear parking valve sub-assembly (EXZ)

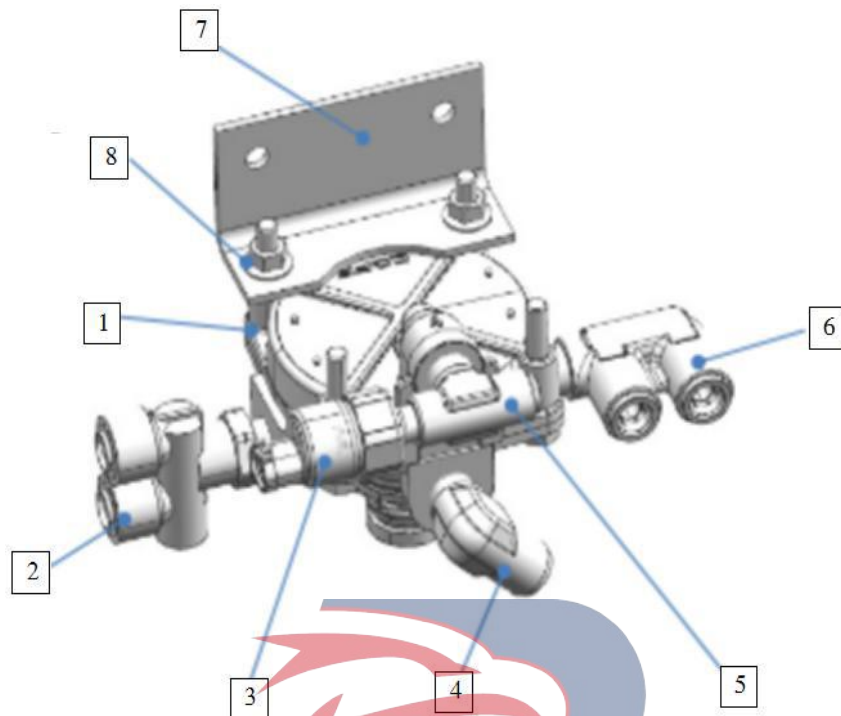

Assembly requirements:

1. Take the connectors (2), (3), (4), (5), and (6), and smear 8-10mm long Loctite 575# thread sealant in the longitudinal direction, starting 2-3 pitches from the lowest part of the thread.
2. Align the sealant-applied connectors (2), (3), (4), (5), and (6) with the valve (1), tighten them by 2-3 turns, and then loosen them by 2-3 turns so as to allow the sealant to be evenly smeared on the valve.
3. Tighten the connectors (2), (3), (4), (5), and (6).
4. As shown in the figure, place the support (7) into the assembly hole shown in the relay valve (1), and put on the nut (8).
5. Tighten the nut (8)

Assembly details:

1. Relay valve
2. Connector (3518046-D17YZ)
3. Switch assembly
4. Connector
5. Connector (3518046-CEZ14)
6. Connector
7. Support
8. Nut (Q32008)

Solenoid valve sub-assembly

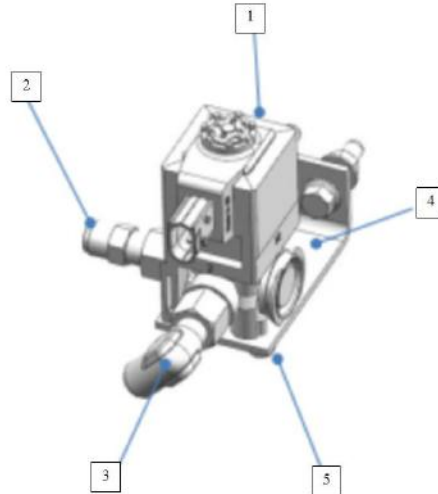

Assembly requirements:

1. Take the connector 2, and smear 8-10mm long thread sealant in the longitudinal direction, starting 2-3 pitches from the lowest part of the thread.
2. Align the sealant-applied connector 2 with the solenoid valve, tighten them by 2 to 3 turns; then loosen them by 2 to 3 turns, so that the sealant is evenly smeared on the solenoid valve body.
3. As shown in the figure, tighten the connector 2. The tightening angle shall be appropriate.
4. Fix the connector 3 to the solenoid valve body in the same way.
5. Fix the support 4 to the solenoid valve 1 using the nut 5.

Assembly details:

1. Solenoid valve
2. Connector
3. Connector
4. Support
5. Bolt (Q1840612)

POWERSTAR

Solenoid valve sub-assembly (transmission with power-take-off)

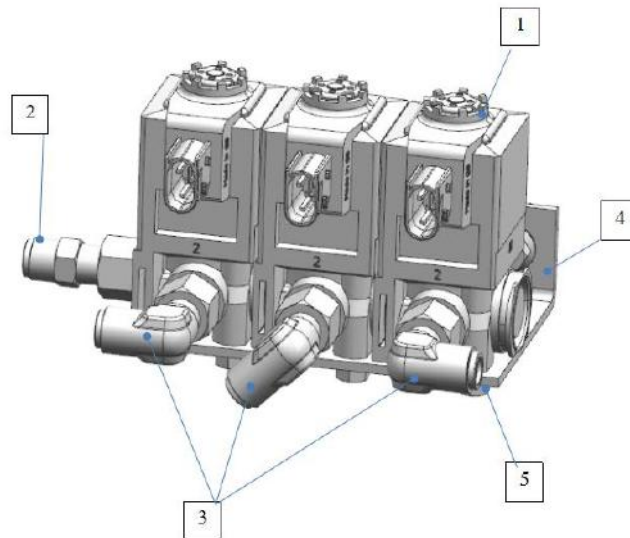

Assembly requirements:

1. Take the connector 2, and smear 8-10mm long thread sealant in the longitudinal direction, starting 2-3 pitches from the lowest part of the thread.
2. Align the sealant-applied connector 2 with the solenoid valve, tighten them by 2 to 3 turns; then loosen them by 2 to 3 turns, so that the sealant evenly smeared on the solenoid valve body.
3. As shown in the figure, tighten the connector 2. The tightening angle shall be appropriate.
4. Fix the connector 3 to the solenoid valve body in the same way.
5. Fix the support 4 to the solenoid valve 1 using the nut 5.

Assembly details:

1. Solenoid valve
2. Connector
3. Connector
4. Support (3754023-D17YZ)
5. Bolt (Q1840612)

POWERSTAR

Front brake valve sub-installing (EXR、EXZ)

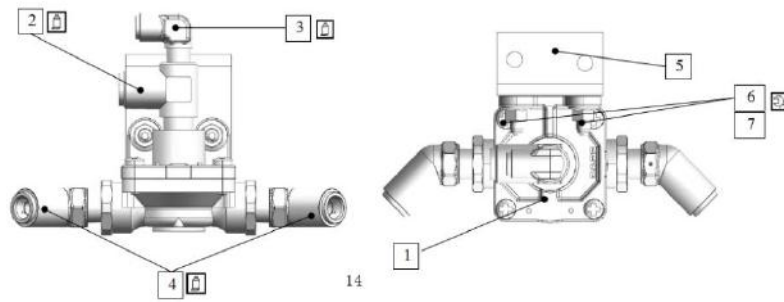

Assembly requirements:

1. Take the connectors (2), (3) and (4), and smear 8-10mm long Loctite 575# thread sealant in the longitudinal direction, starting 2-3 pitches from the lowest part of the thread.
2. Align the sealant-applied connectors (2), (3) and (4) with the valve (1), tighten them by 2-3 turns, and then loosen them by 2-3 turns so as to allow the sealant to be evenly smeared on the valve.
3. Tighten the connectors (2), (3) (4).
4. As shown in the figure, take the bolt (6), pass it through the assembly holes of the support (5) and the relay valve (1), and put on the nut (7).
5. Tighten the nut (7) successively.

Assembly details:

1. Quick release valve
2. Connector (8100661-D17YZ)
3. Connector
4. Connector (3523223-D17YZ)
5. Support (3516217-D17YZ)
6. Bolt (Q1840825)
7. Nut (Q32008)

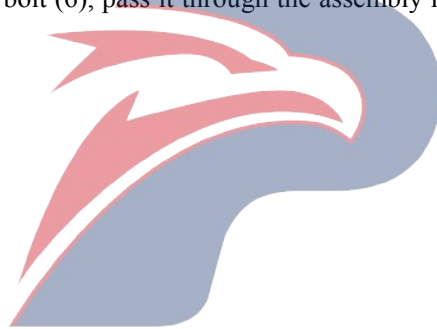

POWERSTAR

Front brake valve assembly

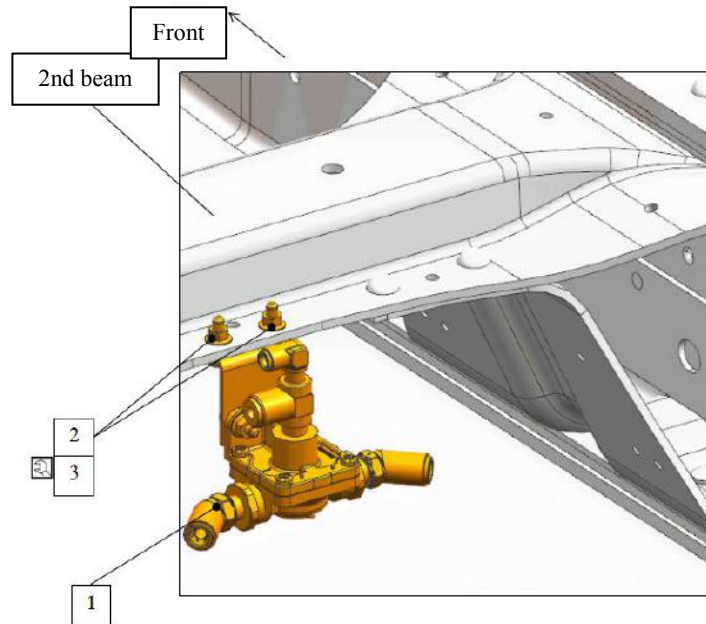

Assembly requirements:

1. As shown in the figure, take the valve assembly (1), put the bolt (3) through the upper mounting hole of the valve assembly (1) and the corresponding hole in the frame, and put on the nut (2) by 2~3 pitches.
2. Tighten the nut (2)

Assembly details:

1. Quick release valve assembly (8974339230)
2. Nut (Q32008)
3. Bolt (Q1840825)

POWERSTAR

Tee connector sub-assembly

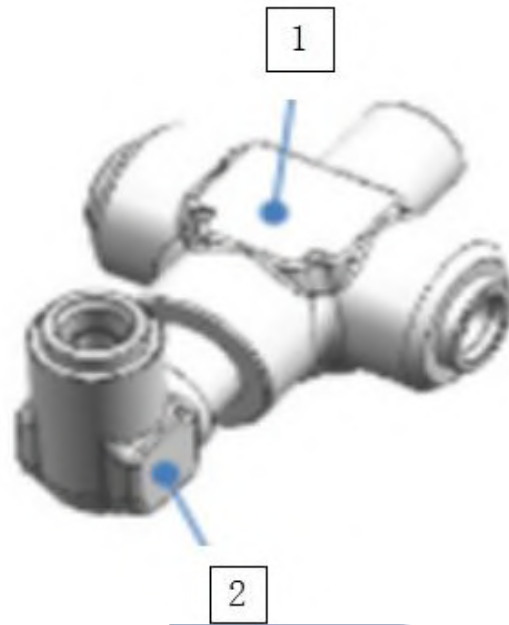

Assembly requirements:

1. Take the connector (2), and smear 8-10mm long Loctite 575# thread sealant in the longitudinal direction, starting 2-3 pitches from the lowest part of the thread.
2. Align the sealant-smeared connector (2) with the tee connector (1), tighten 2 to 3 turns; then unscrew 2 to 3 turns, so that the sealant is evenly smeared on the tee connector.
3. As shown in the figure, fasten the connector (2). The tightening angle shall be appropriate.

Assembly details:

1. Connector
2. Connector

POWERSTAR

Stabilizer bar assembly

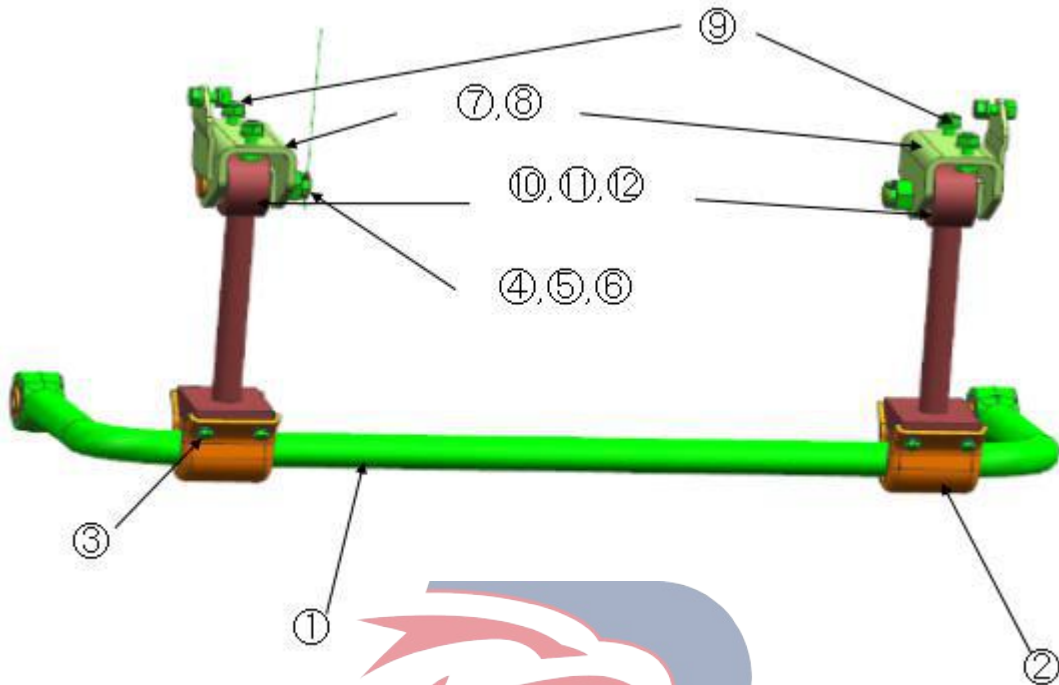

Assembly requirements:

1. The stabilizer bar assembly ①, holder ②, and bolt ③ are connected together;
Fix the support-stabilizer bars ⑦ and ⑧ with the pin ④, nut ⑤ and cotter pin ⑥;
2. Fix the stabilizer bar assembly ⑩ with liner bushing-stabilizer bars ⑪ and ⑫ and bolt ⑨; The bolt should be tight and stable.

Assembly details:

1. Stabilizer bar assembly (2912240-CYR14)
2. Holder (2912261-CYR14)
3. Bolt (2912262-CYR14)
4. Pin (2912263-CYR14)
5. Nut (Q341B24T13)
6. Cotter pin (Q5005045)
7. Support-stabilizer bar (2912264-CYR14)
8. Support-stabilizer bar (2912265-CYR14)
9. Bolt (Q1841016)
10. Stabilizer bar assembly(2912250-CYR14)
11. Lining-stabilizer (2912266-CYR14)
12. Lining-stabilizer (2912267-CYR14)

Frame drawbar assembly

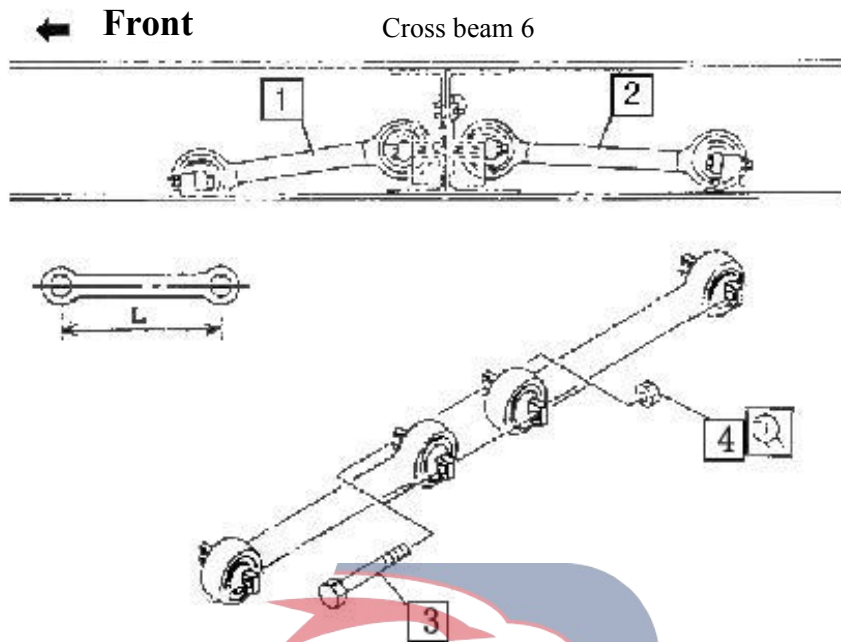

Assembly requirements:

1. Get bolt (3) through the hole on drawbar (1), the middle hole on beam of frame 6, and the hole on the drawbar (2), and finally screw the nut (4).
2. Tighten the nut (4) at a torque of 284 - 343N.m.
3. Spray black paint onto the nut (4).

Assembly details:

1. Upper tie rod-front (2912550-D15EH)
2. Upper tie rod-rear (2912280-D17YZ)
3. Bolt (2912053-130/C)
4. Nut (2912055-130/C)

POWERSTAR

Double rear axle steel plate assembly

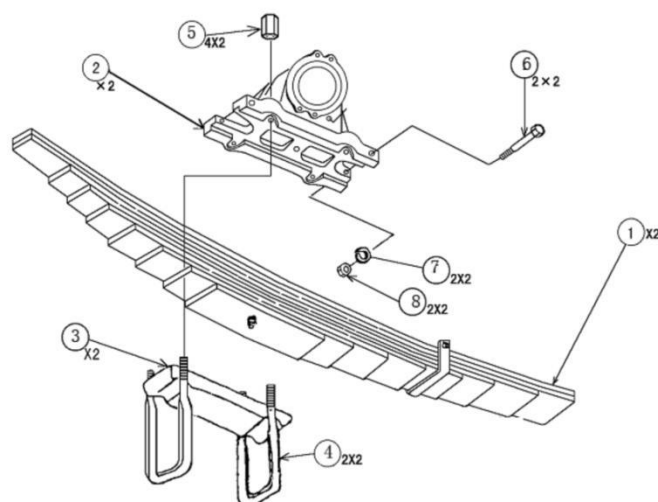

Assembly requirements:

1. Check whether the arc high marks ("+", "-", "0") around the leaf spring are the same. Check the connections of parts ②, ③, ④ and make it clean, if not, clean them with cotton.
2. As shown in the figure, preliminarily connect and fasten the rear leaf spring assembly ①, base ② and the upper plate ③ with U-shaped bolt ④ and nut ⑤.. Note: U-shaped bolt ④ should be installed in the groove on the plate ③; the bolt mounting holes of base ② should be facing outward;
3. Assemble bolt ⑥, washer ⑦, nut ⑧ on the base ②, no tightening.

Assembly details:

1. Rear leaf spring assembly (2912010-D17YZ)
2. Support
3. Bolt
4. Washer (Q40522)
5. Nut (Q341B22T13(M22×1.5))
6. Pressure plate
7. Rear U-shaped bolt
8. Nut (2912052-130/C)

POWERSTAR

Double rear axle support assembly

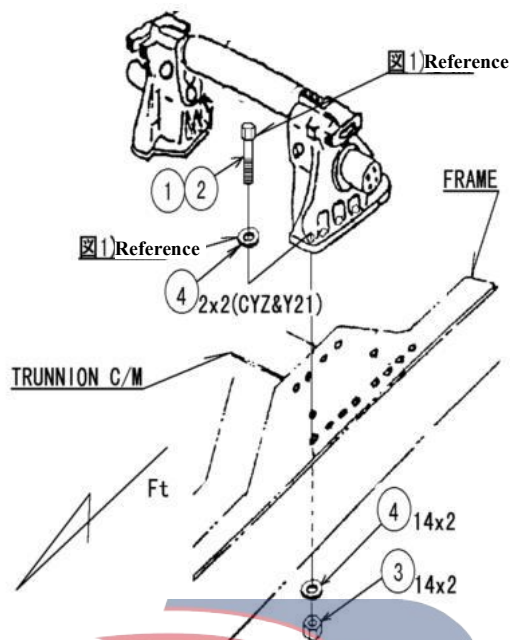

Assembly requirements:

1. Take the washer (1), bolt (2), bolt (3) and nut (4) to connect the rear axle with double rear axle to the frame according to the installation direction as shown in the figure. Installation sequence: According to the picture Installation hole location map From top to bottom, assembly from left to right. Note: The installation direction of bolts, nuts and washers is as shown in the figure.
2. Tighten the nut (4) at a torque of $320\pm 30\text{N.m}$.
3. Spray black paint on combination surface of the double rear axle spring bearing and bolt and nut .

Assembly details:

1. Bolt
2. Bolt (Q151B1855TF2)
3. Nut (Q341B18)
4. Washer

POWERSTAR

Support lower tie rod assembly (EXZ. CXZ)

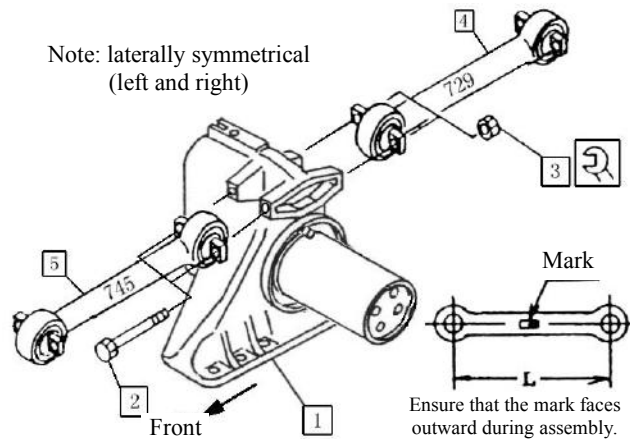

Assembly requirements:

1. As shown in the figure, take the bolt (2), put it through the holes of the pull rod (5), the base (1), and the pull rod (4), and screw on the nut (3).
2. Tighten the nut (3) at a torque of 284-343Nm.
3. Spray black paint on the nut (3).

Assembly details:

1. Support (2918013-130/C)
2. Bolt (2912053-130/C)
3. Nut (2912055-130/C)
4. Upper tie rod-rear (2912280-D17YZ)
5. Upper tie rod-front(2912550-D17YZ)



POWERSTAR

Fix the ABS sensor harness (EXZ)

Attached drawing

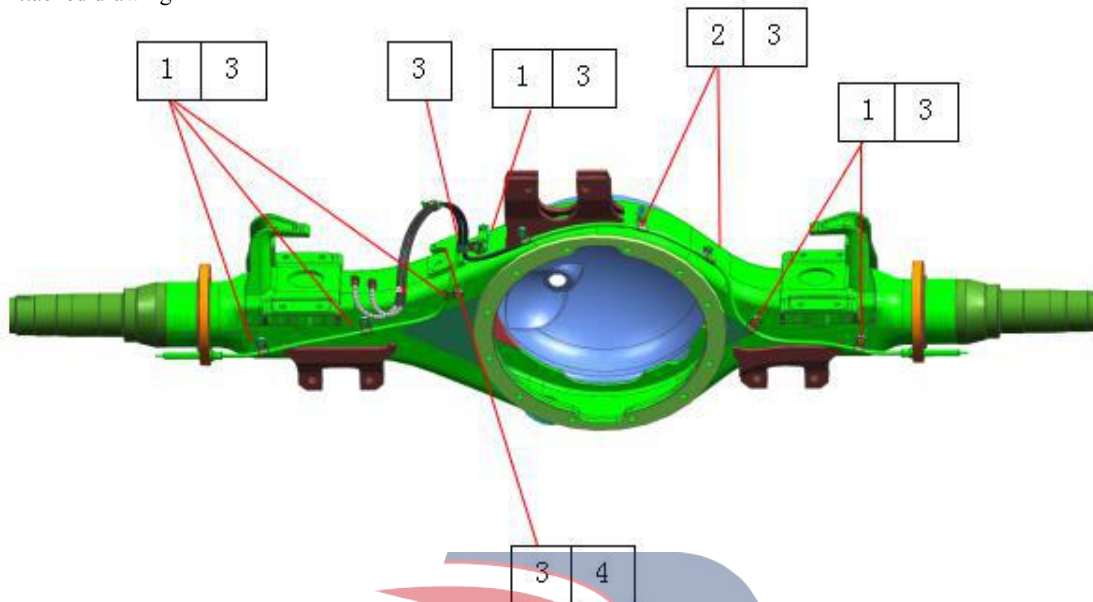

Assembly requirements:

1. Run the ABS sensor wiring harness in the direction as shown in the figure and fix it as shown therein;
2. Fix the ABS sensor harness into the corresponding mounting holes with harness clips ①, ② and ④, fix the harness with bolt ③ using a pneumatic wrench, make it tight and stable.

Assembly details:

1. ABS wiring harness clip (3204156-D17YZ)
2. ABS wiring harness clip
3. Bolt (Q1840816)
4. ABS wiring harness clip

POWERSTAR

Fix the ABS sensor harness (EXR)

Attached drawing

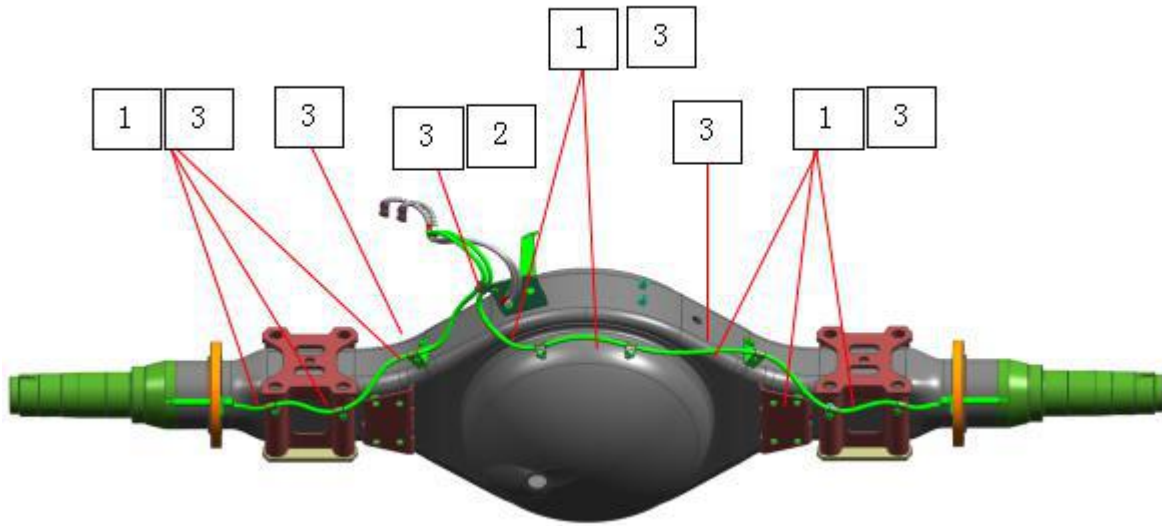

Assembly requirements:

1. Run the ABS sensor wiring harness in the direction as shown in the figure and fix it as shown therein;
2. Fix the ABS sensor harness into the corresponding mounting holes with harness clips ①, ②, fix the harness with bolt ③ using a pneumatic wrench, and make it tight and stable.

Assembly details:

1. ABS wiring harness clip (3204156-D17YZ)
2. ABS wiring harness clip
3. Bolt (Q1840816)

POWERSTAR

Rear relay valve sub-assembly

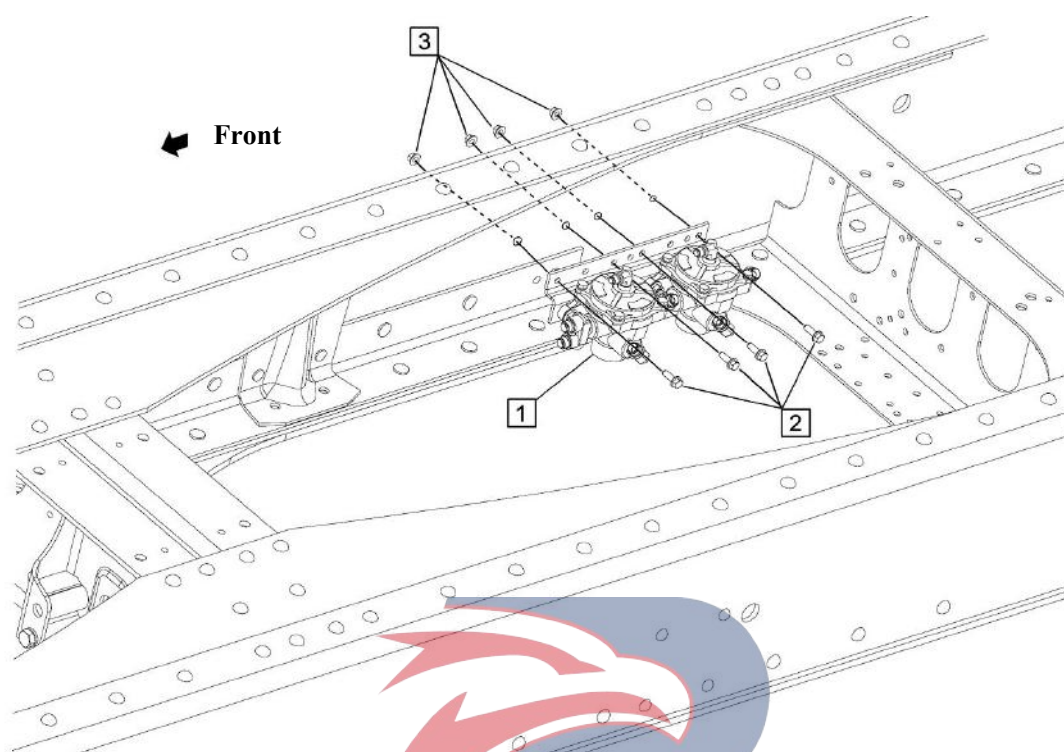

Assembly requirements:

1. As shown in the figure, insert bolt (2) into the left hole on valve assembly (1), and then insert it into the corresponding hole on the frame
2. Put on the nut (3)
3. Tighten nut (3)

Assembly details:

1. Relay valve (8974339200)
2. Bolt (Q1840825)
3. Nut (Q32008)

POWERSTAR

Rear axle nylon tube mounting bracket assembly

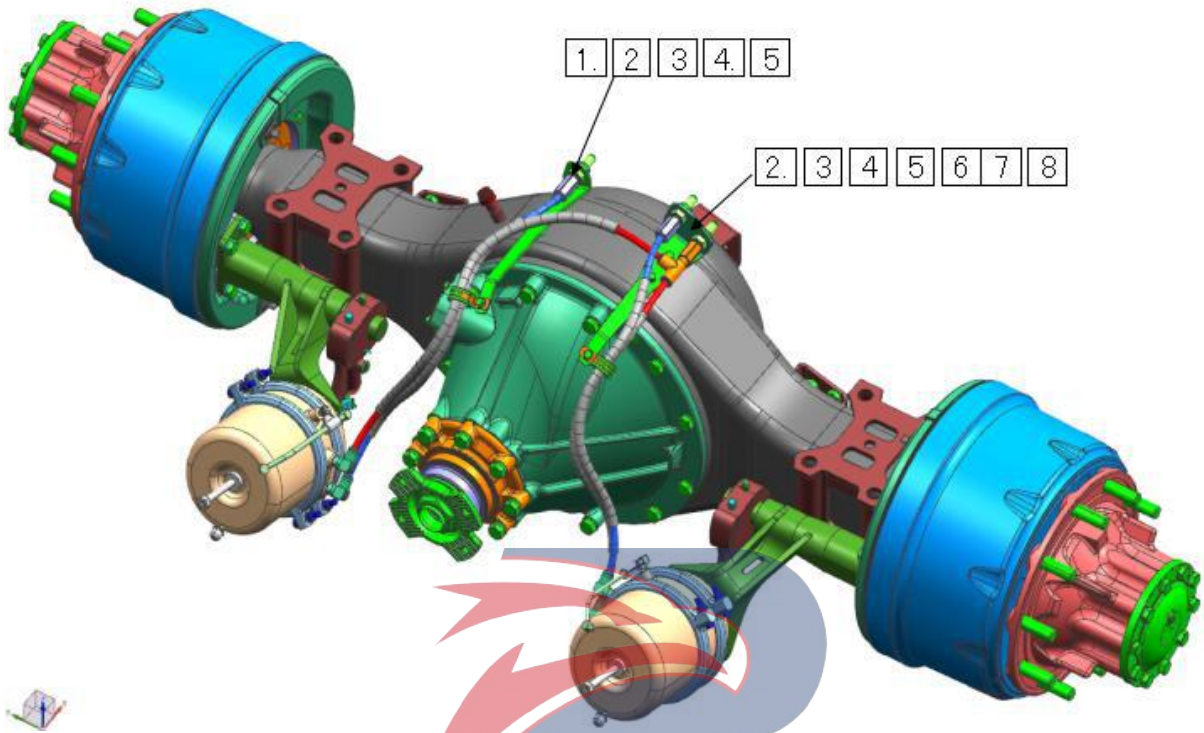

Assembly requirements:

1. As shown in the figure, assemble parts (1), (2), (3), (4), (5), (6), (7) and (8).

Assembly details:

1. Bracket
2. Connector (3521056-CYR14)
3. Nut (Q341B16T12)
4. Spring washer (Q40516)
5. Connector (3506121-D15YR)
6. Bracket (3506111-D15YZ)
7. Connector
8. Connector (3506122-D15YR)

Rear axle nylon tube connection

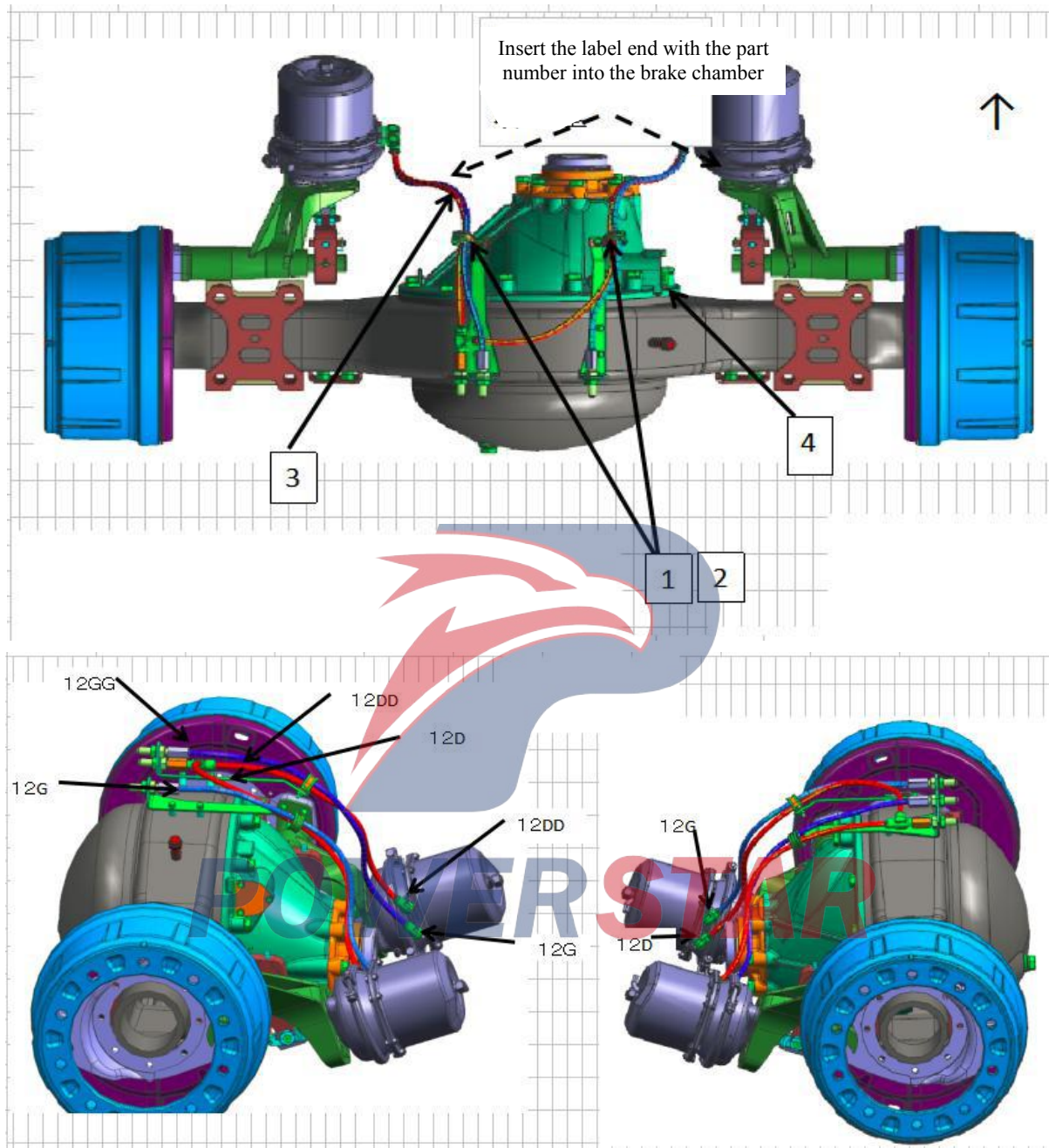

Assembly requirements:

1. As shown in the figure, assemble parts (1)(2)(3) and (4).

Assembly details:

1. Clip
2. Bolt (Q1840820)
3. Nylon tube (3506330-D15YR)
4. Nylon tube (3506320-D15YR)

Rear parking brake hose sub-assembly

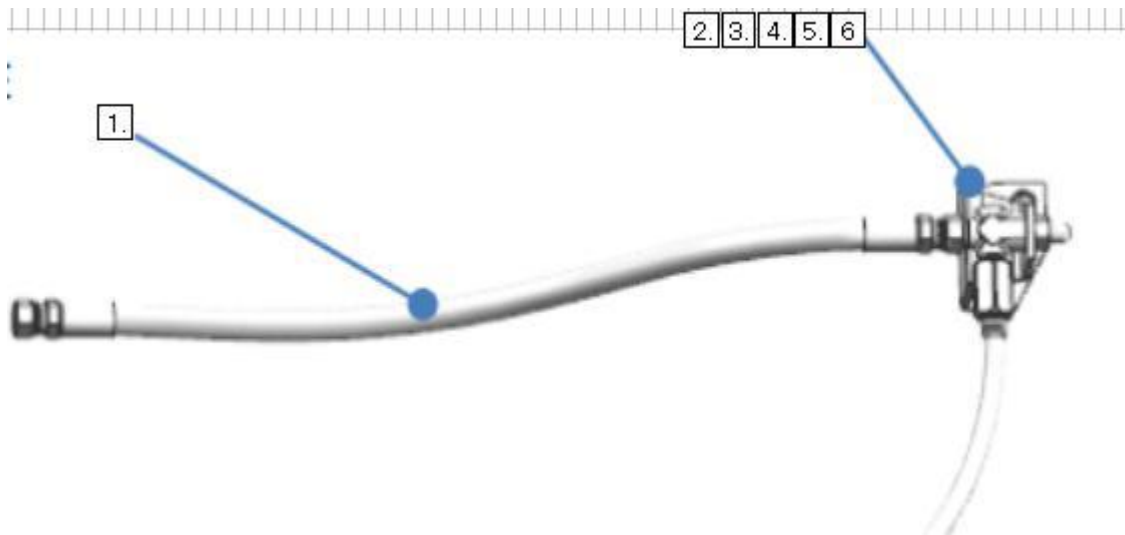

Assembly requirements:

1. As shown in the figure, assemble parts (1) (2) (3) (4) (5) and (6).

Assembly details:

1. Hose assembly (3506320-CYR14)
2. Connector
3. Bracket
4. Bolt (Q1841025)
5. Nut (Q341B12)
6. Connector (3506121-D15YR)

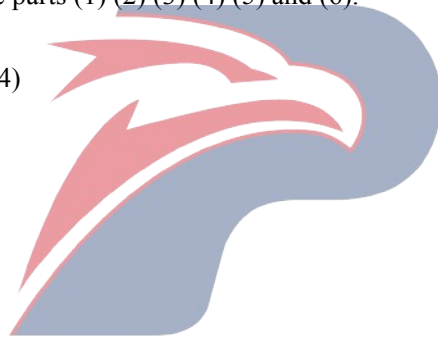

POWERSTAR

Support assembly for shift cable and upshift/downshift air pipe

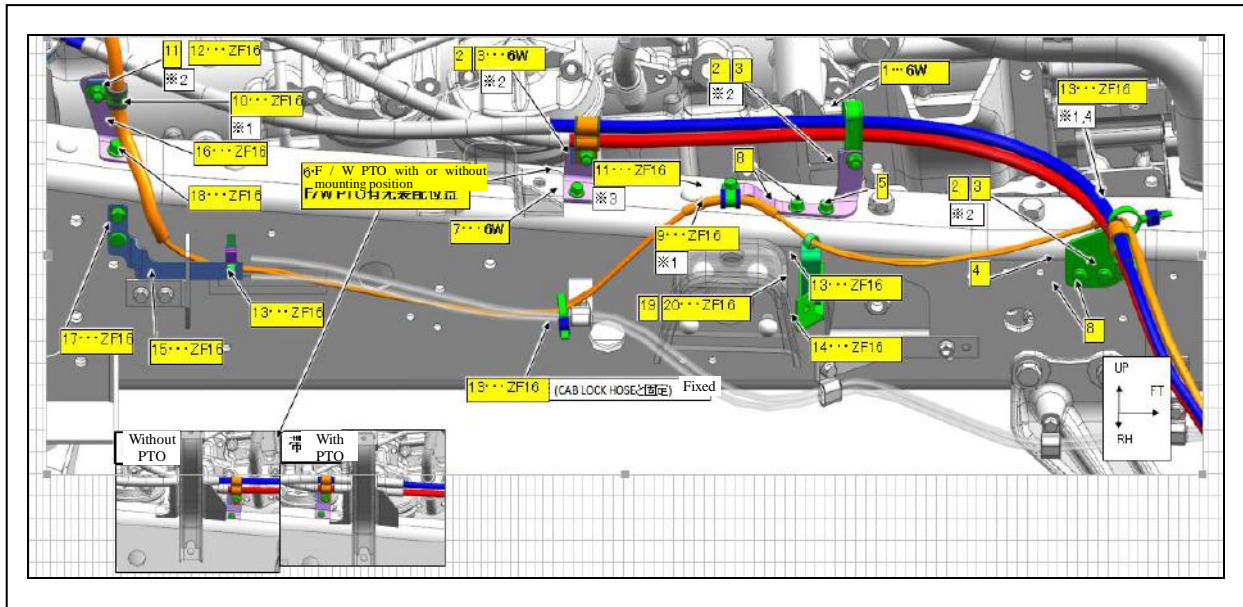

Assembly requirements:

1. Assemble parts (1) (2) (3) (4) (5) (6) (7) (8) (9) (10) (11) (12) (13) (14) (15) (16) (17) (18) (19) and (20) as shown in the figure.

Assembly requirements:

1. Clip
2. Bolt (Q1840820)
2. Bolt (Q1840820)
3. Nut (Q32008)
3. Nut (Q32008)
4. Support-shift cable
5. Support-shift cable (1702162-D17YZ)
6. Support-shift cable (1702163-D16YZ)
7. Bolt (Q1840825)
8. Bolt (Q1840830)
9. Clip
10. Clip(3724139-D17YZ)
11. Bolt (Q1840820)
12. Bolt (Q32008)
13. Nut
14. Binding tape
15. Binding tape (1703271-D17YZ)
16. Support (1703272-D17YZ)
17. Support (1703273-D17YZ)
18. Support (Q1840825)
19. Bolt (Q1840835)
20. Bolt (Q1840830)

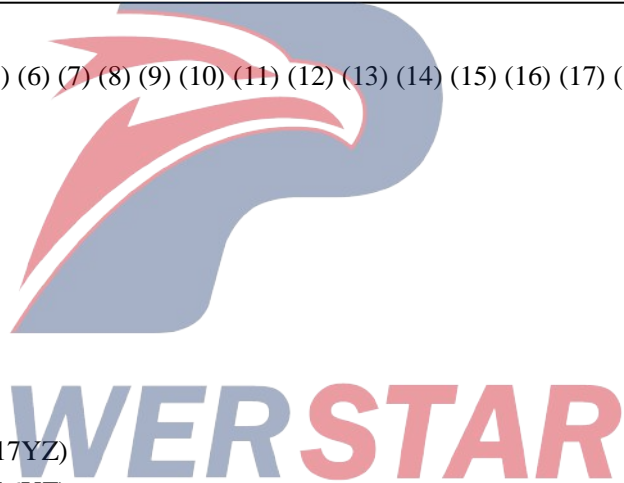

Left mounting support assembly of cab

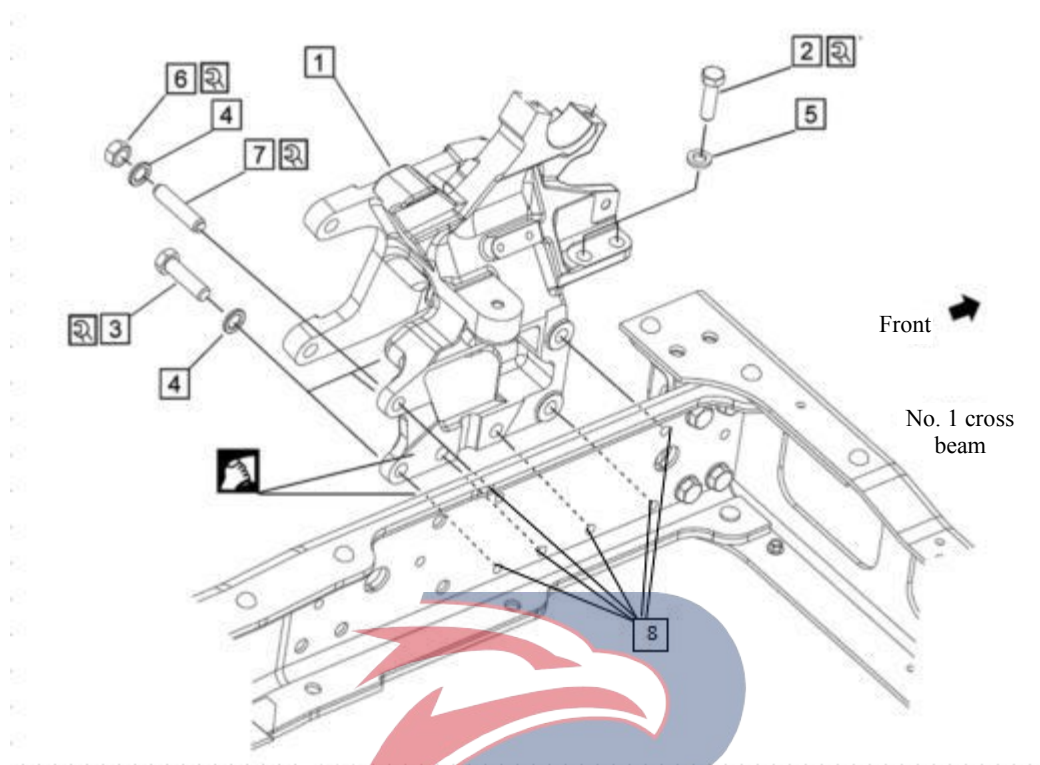

Assembly requirements:

1. As shown in the figure, install the support assembly – cab installation (1) onto the mounting hole on the left side of the frame.
2. Put bolts (2) and (3) and stud (7) into washers (4) and (5) as shown on the right, get them through support assembly - cab installation (1), and screw
3. Tighten bolts (3) and (7) at a torque of $219\pm 21\text{N.m}$.
4. Tighten bolt (2) at a torque of $157\pm 14\text{N.m}$.

Assembly details:

1. Support assembly-cab installation (5001011-D17YZ)
2. Bolt (Q151B1450TF2)
3. Washer (Q151B1660T)
4. Stud
5. Nut (2801104-113)
6. Washer (Q341B16)
7. Bolt (
8. Nut (Q32016T13(P=1.5))

Right mounting support assembly of cab

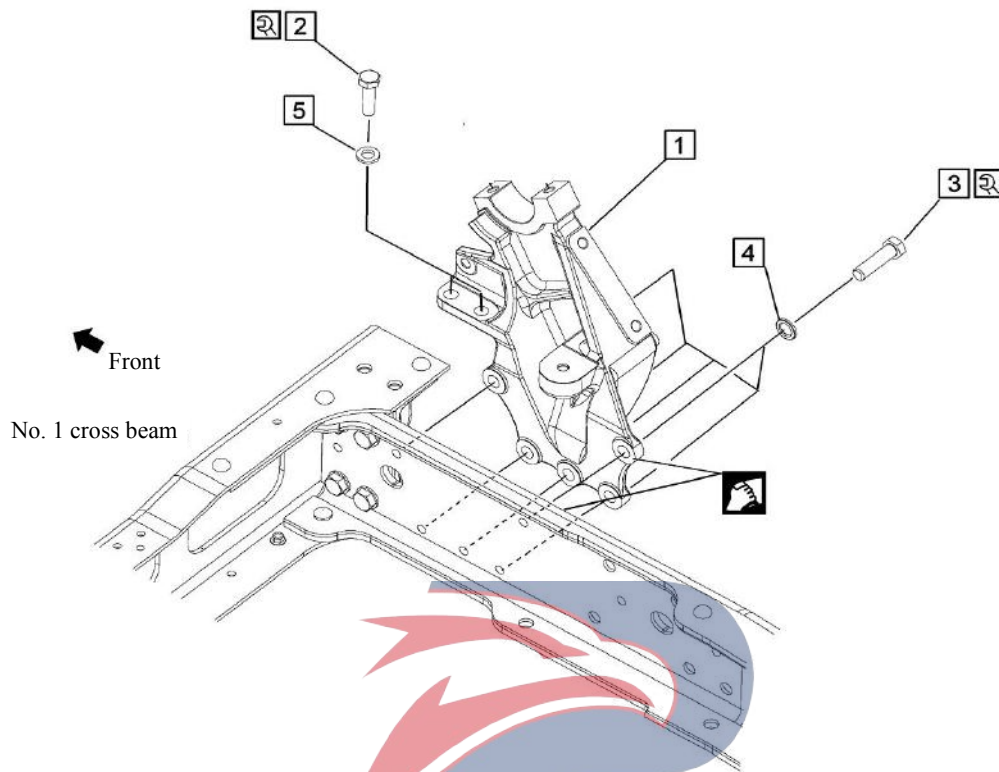

Assembly requirements:

1. As shown, install the support assembly - cab installation (1) onto the mounting hole on the right side of the frame.
2. Get the bolt (2) and (3) through support assembly - cab installation (1) as shown on the right, and screw them into the welding nut of the mounting hole on the right side of the frame by 2~3 threads.
3. Tighten bolt (3) at a torque of $219\pm 21\text{N.m}$.
4. Tighten bolt (2) at a torque of $157\pm 14\text{N.m}$.

Assembly details:

1. Support assembly - cab installation (8203920-D17YZ)
2. Bolt (Q151B1450TF2)
3. Bolt (Q151B1660T)
4. Washer
5. Washer (2801104-113)
6. Nut (Q32016T13(P=1.5))

Step fitting

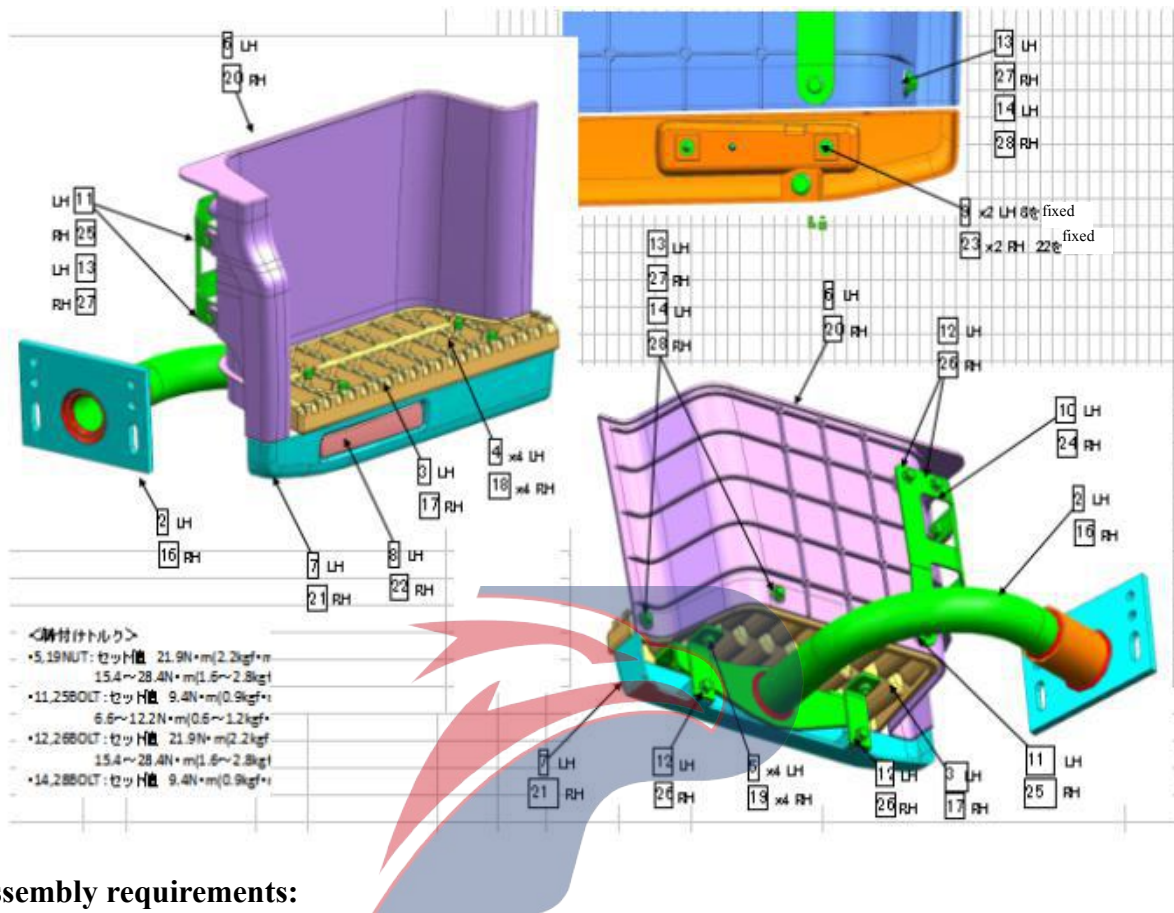

Assembly requirements:

1. Attach the steps 3 and 4 to the support assembly - steps 1 and 2 with bolt 5 and nut 6, and tighten the bolts.
2. Attach the baffles 8 and 94 on the steps 3 and 4 with bolt 10 and washer 7, and tighten the bolts.
3. Attach brackets 11 and 12 on the baffles 8 and 9 with bolts 13, 14 and 15 and washer 16.

Assembly details:

1. Step assembly (——)
2. Step assembly (8405211-D17YZ)
3. Step assembly (8405240-D17YZ)
4. Bolt (Q1840840)
5. Nut (Q32008)
6. Baffle - right side of step (8405246-D17YZ)
7. Retaining plate (8405247-D17YZ)
8. Reflector (8973789100)
9. Nut clamp piece (8405013-P301)
10. Support (8405245-D17YZ)
11. Bolt (Q1840625)
12. Bolt (Q1840816)
13. Washer (Q40106)

14. Bolt (Q1840616)
15. Step assembly (—)
16. Step assembly (8405201-D17YZ)
17. Step assembly (8405230-D17YZ)
18. Bolt (Q1840840)
19. Nut (Q32008)
20. Retaining plate—Step left(8405236-D17YZ)
21. Retaining plate (8405237-D17YZ)
22. Reflector (8973789100)
23. Nut clamp piece (8405013-P301)
24. Support (8405235-D17YZ)
25. Bolt (Q1840625)
26. Bolt (Q1840816)
27. Washer (Q40106)
28. Bolt (Q1840616)

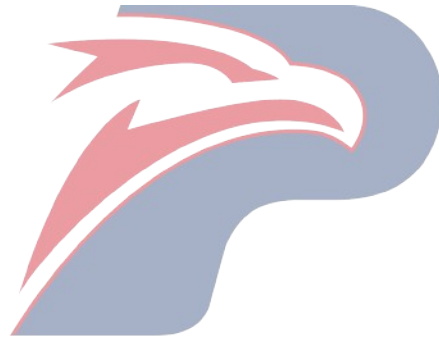

POWERSTAR

Step installation

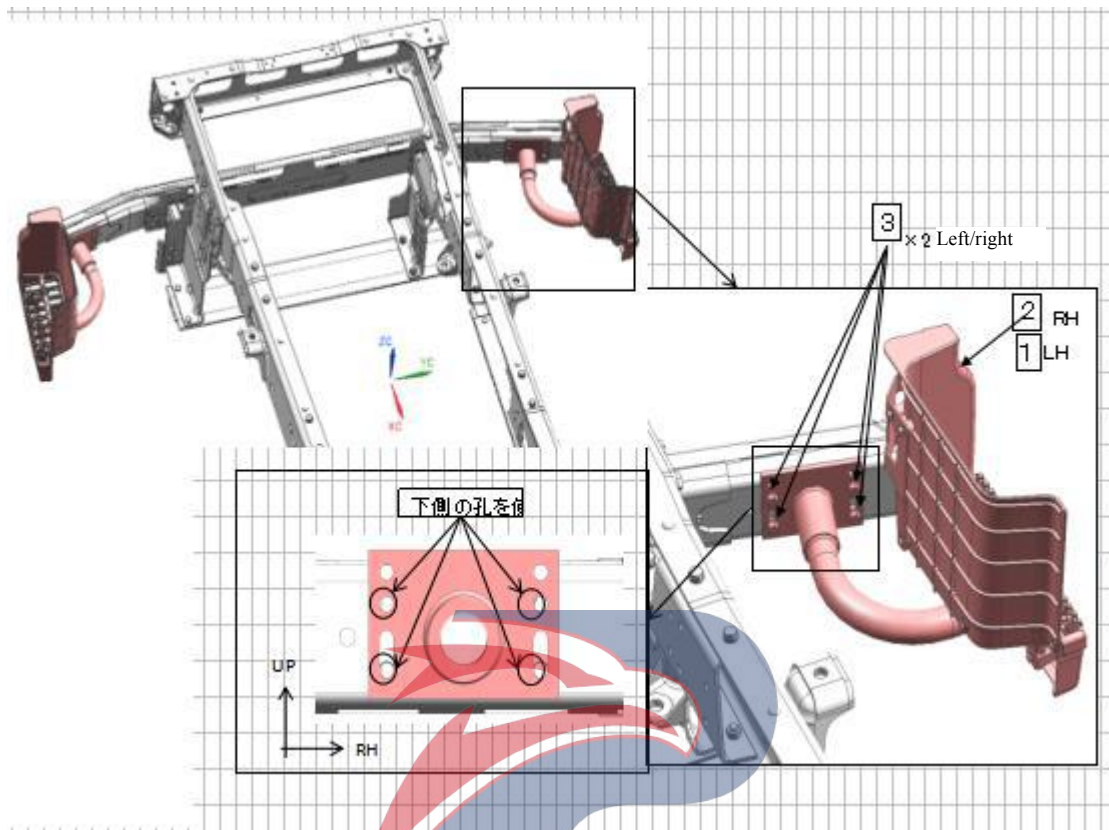

Assembly requirements:

1. Install the step assembly (1) (2) onto the front guard with bolt (3), and tighten the bolts.

Assembly details:

1. Step assembly (8405210-D17YZ)
2. Step assembly (8405200-D17YZ)
3. Bolt (Q1841230 (P=1.25))

POWERSTAR

Air reservoir sub-assembly (EXZ, EXR)

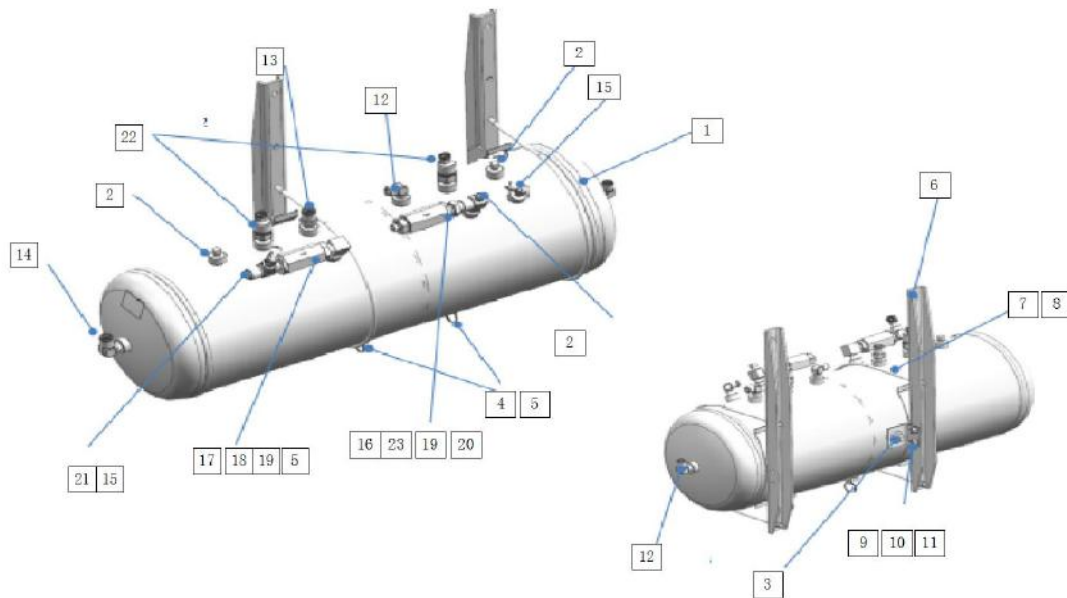

Assembly requirements:

1. Install the support 9 to the support 6 with the bolt 10 and nut 11.
2. As shown in the figure, take (2) and (3). Smear 8-10mm long sealant in the longitudinal direction, starting 2-3 pitches from the lowest part of the thread.
3. Screw the sealant-applied connectors (2) and (3) into the air tank (1), tighten them two or three turns, and then loosen them two or three turns so as to allow the sealant to be evenly smeared on the joint.
4. Tighten the parts (2) and (3) successively.
5. Take the water discharge valve (4), put on the gasket (5), and screw it into the air tank (1). Tighten the water drain valve (2) with the confirmed torque of $22.5 \pm 6.9 \text{ Nm}$ and make a red inkpad mark.
6. Fix the assembled air tank (1) on the support (6) using the U-shaped fixing screw (7) and the nut (8).

Assembly details:

1. Air reservoir assembly (3513050-D17YZ)
2. Plug (3513115-150)
3. Plug (3513113-117/C)
4. Water discharge valve
5. Gasket (3506904-CEH24)
6. Support (3513216-D17YZ)
7. U-shaped fixing screw
8. Nut (Q340B08)
9. Support
10. Bolt(Q1840820)
11. Nut(Q32008)
12. Connector
13. Connector
14. Connector
15. Connector
16. Connector (3506181-D17YZ)
17. Connector
18. Connector

- 19. Check valve (3515011-CEZ14)
- 20. Connector(3506422-D17YZ)
- 21. Connector(3506423-D17YZ)
- 22. Low-voltage switch
- 23. Connector (3515016-CEZ14)

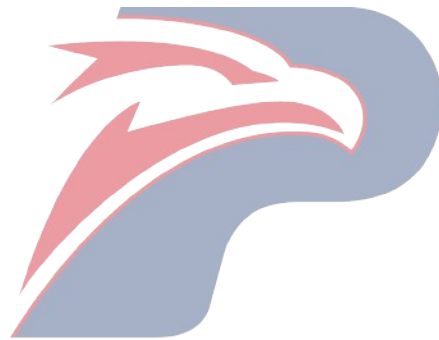

POWERSTAR

Air reservoir sub-assembly (2)(EXZ)

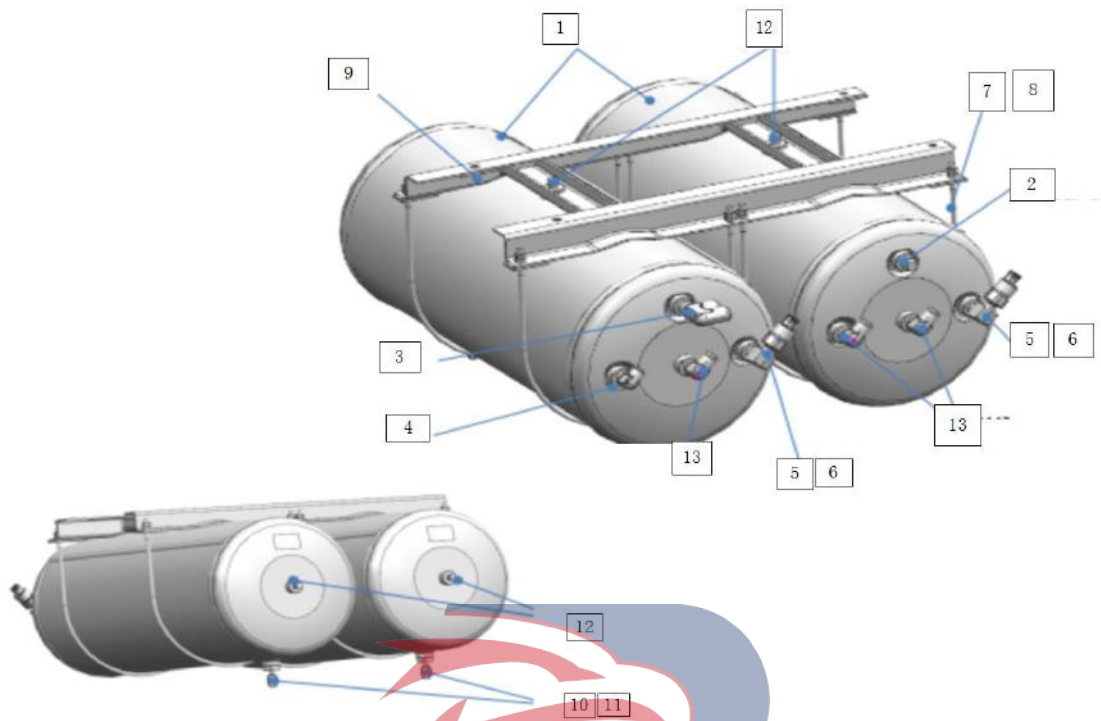

Assembly requirements:

1. Take the water discharge valve (11), put on the gasket (12), and screw it into the air tank (1). Tighten the water discharge valve (11) with the confirmed torque of $22.5 \pm 6.9 \text{Nm}$ and make a red inkpad mark.
2. Fix the assembled air tank (1) on the support (10) using the U-shaped fixing screw (8) and the nut (9).
3. As shown in the figure, take the plug (2). Smear 8-10mm long sealant in the longitudinal direction, starting 2-3 pitches from the lowest part of the thread.
4. Screw the sealant-applied connector (2) into the air tank (1), tighten it two or three turns, and then loosen it two or three turns so as to allow the sealant to be evenly smeared on the joint.
5. Tighten the parts (2) successively.
6. Tighten the connectors 3-7 using the same method. The tightening angle shall be appropriate.

Assembly details:

1. Air reservoir assembly (3513211-D17YZ)
2. Plug (3513113-117/C)
3. Connector
4. Connector (
5. Connector
6. Low-voltage switch
7. U-shaped fixing screw (3513528-D17YZ)
8. Nut (Q340B08)
9. Support-air reservoir (3513216-D17YZ)
10. Water discharge valve
11. Gasket (3506904-CEH24)
12. Plug (3513115-150)
13. Connector

Air reservoir sub-assembly (2)(EXR)

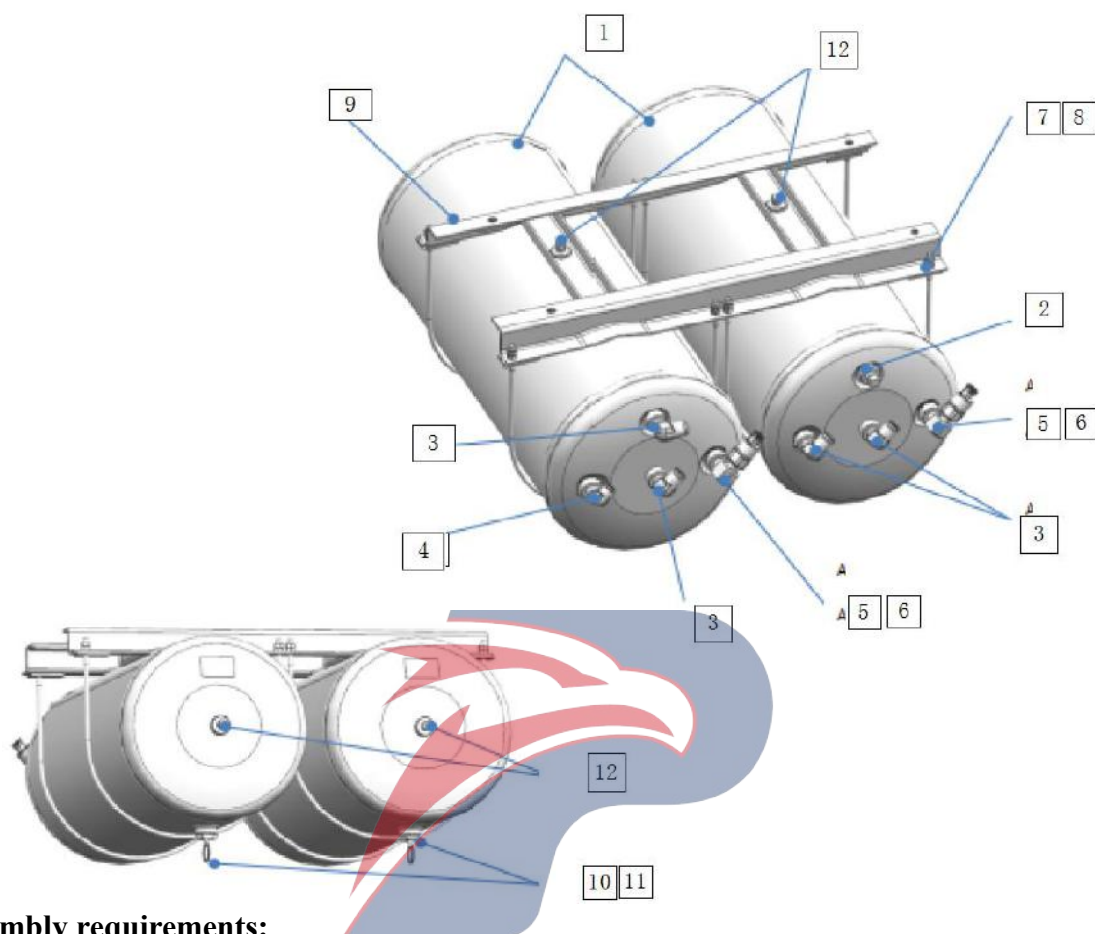

Assembly requirements:

1. Take the water discharge valve (11), put on the gasket (12), and screw it into the air tank (1). Tighten the water discharge valve (11) with the confirmed torque of $22.5 \pm 6.9 \text{ Nm}$ and make a red inkpad mark.
2. Fix the assembled air tank (1) on the support (10) using the U-shaped fixing screw (8) and the nut (9).
3. As shown in the figure, take the plug (2). Smear 8-10mm long sealant in the longitudinal direction, starting 2-3 pitches from the lowest part of the thread.
4. Screw the sealant-applied connector (2) into the air tank (1), tighten it two or three turns, and then loosen it two or three turns so as to allow the sealant to be evenly smeared on the joint.
5. Tighten the parts (2) successively.
6. Tighten the connectors 3-7 using the same method. The tightening angle shall be appropriate.

Assembly details:

1. Air reservoir assembly (3513211-D17YZ)
2. Plug (3513113-117/C)
3. Connector
4. Connector
5. Connector
6. Low-voltage switch
7. U-shaped fixing screw (3513528-D17YZ)
8. Nut (Q340B08)
9. Support-air reservoir (3513216-D17YZ)
10. Water discharge valve
11. Gasket (3506904-CEH24)
12. Plug (3513115-150)

Air reservoir sub-assembly (tail reservoir) (EXZ)

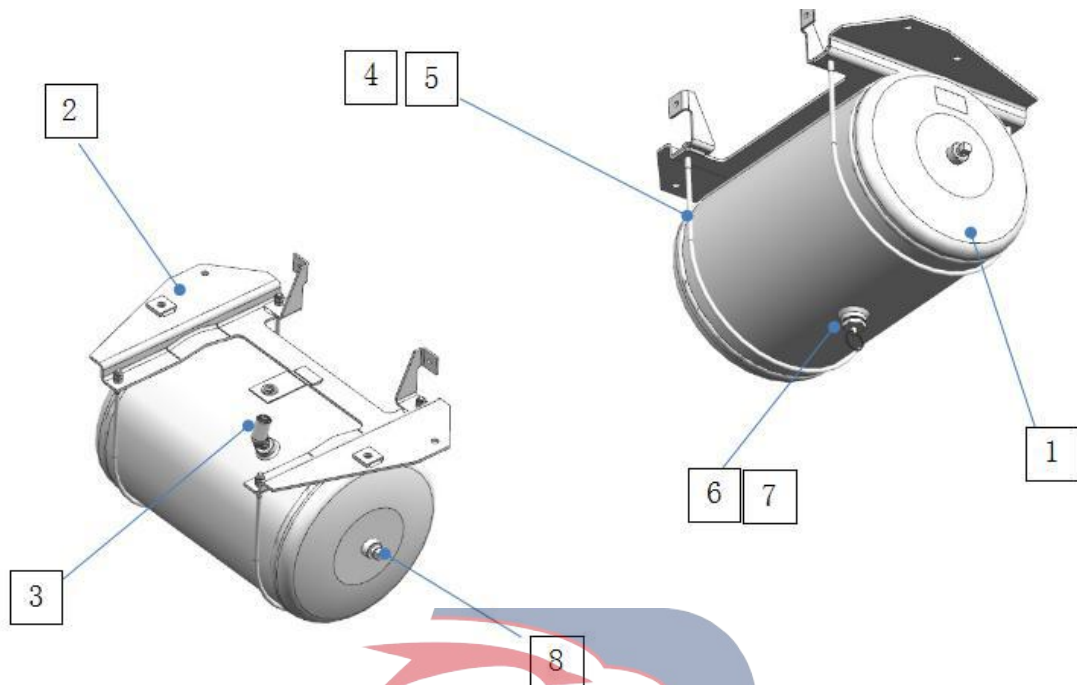

Assembly requirements:

1. As shown in the figure, take the plug (8). Smear 8-10mm long sealant in the longitudinal direction, starting 2-3 pitches from the lowest part of the thread.
2. Screw the sealant-applied connector (8) into the air tank (1), tighten it two or three turns, and then loosen it two or three turns so as to allow the sealant to be evenly smeared on the joint.
3. Fastener (8).
4. Fix the air reservoir (1) on the supports (2) and (9) using the U-shaped fixing screw (4) and the nut (5).
5. Take the water discharge valve (6), put on the gasket (7), and screw it into the air reservoir (1). Tighten the water discharge valve (6) with the confirmed torque of $22.5 \pm 6.9 \text{ Nm}$ and make a red inkpad mark.
6. Tighten the connector 3 using the method to assemble the plug. The tightening angle shall be appropriate.

Assembly details:

1. Air reservoir (3513231-D25EH)
2. Support (3606323-D17YZ)
3. Connector (3523223-D17YZ)
4. U-shaped fixing screw (3513528-D17YZ)
5. Nut (Q340B08)
6. Water discharge valve
7. Gasket (3506904-CEH24)
8. Plug (3513113-117/C)

Spring assembly

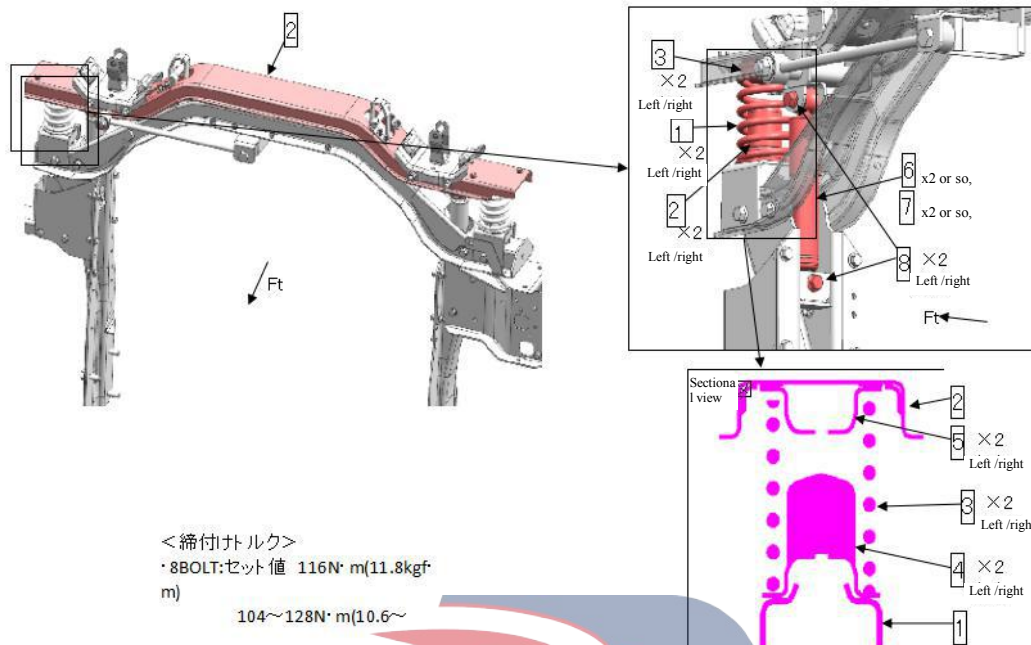

Assembly requirements:

1. Take the connector 5, and smear 8-10mm long Loctite 575# thread sealant in the longitudinal direction, starting 2-3 pitches from the lowest part of the thread.
2. Screw the sealant-applied connector (5) into the air spring assembly (1) two or three turns; then loosen it two or three turns so as to allow the sealant to be evenly smeared on the connector (5).
3. As shown in the figure, tighten the connector (5). The tightening angle shall be appropriate.
4. Take the sub-assembled air spring assembly (1) and connect its upper end to the cross beam by using the bolt (4) and connect its lower end to the portal frame support assembly by using the bolt (3) conductor-air spring (2).
5. Tighten bolts (3) and (4).

Assembly details:

1. Support assembly
2. Support assembly
3. Coil spring
4. Rubber gasket
5. Pedestal
6. Damper assembly (8202520-D34EZ)
7. Damper assembly (8202520-D34EZ)
8. Bolt (Q1841260T(P=1.25))

Oil pipe connection (6W high ceiling)

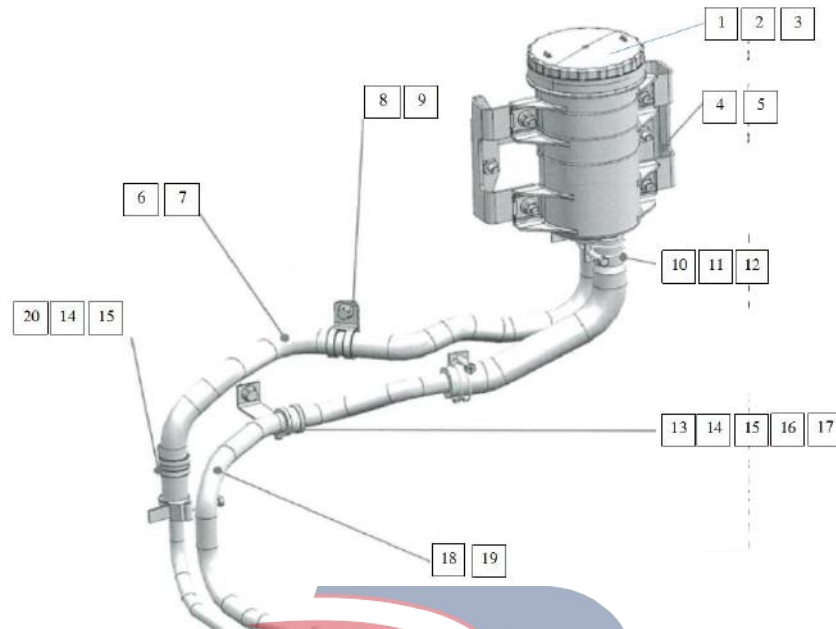

Assembly requirements:

1. Fix the oil tank assembly-power steering gear 1 to the support-steering oil tank 4 with the parts 2, 3, and 5.
2. Connect the rubber hoses-oil tank inlet and outlet 6 and 10 to the oil tank with the parts 7 and 11.
3. Connect the part 10 to the part 12 with the part 11; fix the part 6 on the support with the parts 8 and 9; fix the part 12 with the parts 13 and 14.
4. Connect the parts 12 and 19 to each other using the part 20.
5. Fix the part 12 using the parts 13-18.

Assembly details:

1. Oil tank assembly-power steering gear
2. Bolt (Q1840825)
3. Nut (Q32008)
4. Support-steering oil tank
5. Bolt (Q1840825)
6. Rubber hose-oil tank inlet (3408035-D17YZ)
7. Clip (
8. Clip
9. Bolt (Q1840820)
10. Rubber hose- oil tank outlet (3408039-D17YZ)
11. Clip
12. Clip (
13. Clip
14. Bolt (Q1840820)
15. Nut (Q32008)

- 16. Support
- 17. Bolt (Q1840820)
- 18. Hard hose - pump inlet (3408042-D17YZ)
- 19. Rubber hose - pump inlet (3408044-D17YZ)
- 20. Clip

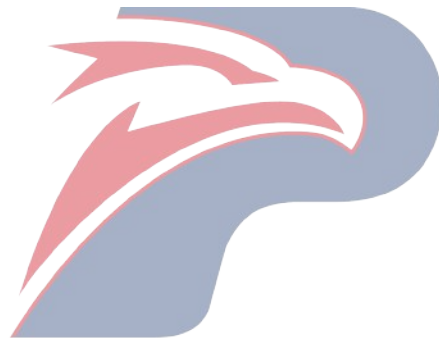

POWERSTAR

Expansion water tank assembly and hose assembly

6w engine flat-roof cab assembly:

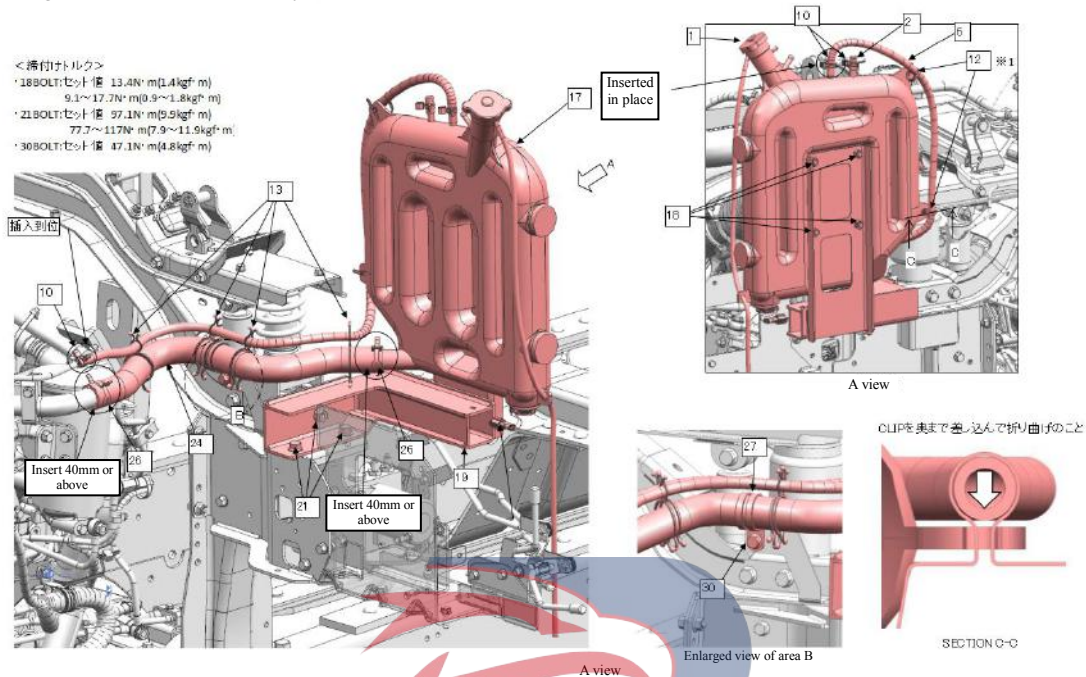

Assembly requirements:

1. Affix the warning sign-fill antifreeze 1 onto the cover of expansion water tank assembly 8.
2. Fix the support 10 onto the gantry with bolt 11.
3. Fix the expansion water tank assembly 8 onto the support 10 with bolt 9.
4. Connect and fix hose 4 with clips 5,6 and 7.
5. Connect and fix hose 12 with clips 13 and 14, bolts 3 and 15, and support 2.

Assembly details:

- | | |
|---------------------------------|-----------------------------------|
| 1. Warning sign | 15. Clip |
| 2. Rubber cover (1301315-D17YZ) | 16. Clip |
| 3. Support (1301116-D15YZ) | 14. Bolt (Q1840820) |
| 4. Bolt (Q1840820) | 15. Nut (Q32008) |
| 5. Nut (Q32008) | 16. Support |
| 6. Water pipe (1301025-D34EZ) | 17. Expansion water tank assembly |
| 7. Hose | 18. Bolt |
| 8. Hose | 19. Support |
| 9. Hose (1301026-D15YR) | 20. Support (1301231-D17YZ) |
| 10. Clip (1104102-117/C) | 21. Bolt (Q1841230(P=1.25)) |
| 11. Clip (1104102-117/C) | 22. Hose |
| 12. Clip | 23. Hose (1301132-D15YR) |
| 13. Clip | 24. Hose (1301132-D34EZ) |
| 14. Clip | 25. Hose (1301032-D17YZ) |

26. Clip
27. Clip
28. Clip
29. Clip

30. Bolt (Q1841025(P=1.25))
31. Bolt (Q1841025(P=1.25))
32. Bolt (Q1841025(P=1.25))

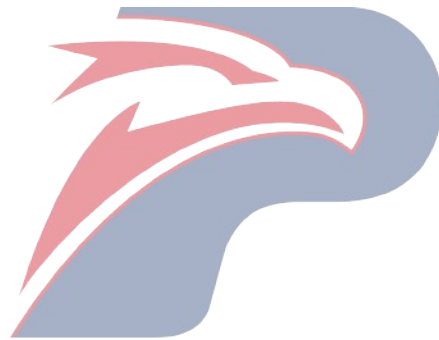

POWERSTAR

Lifter oil pipe gantry sub-assembly

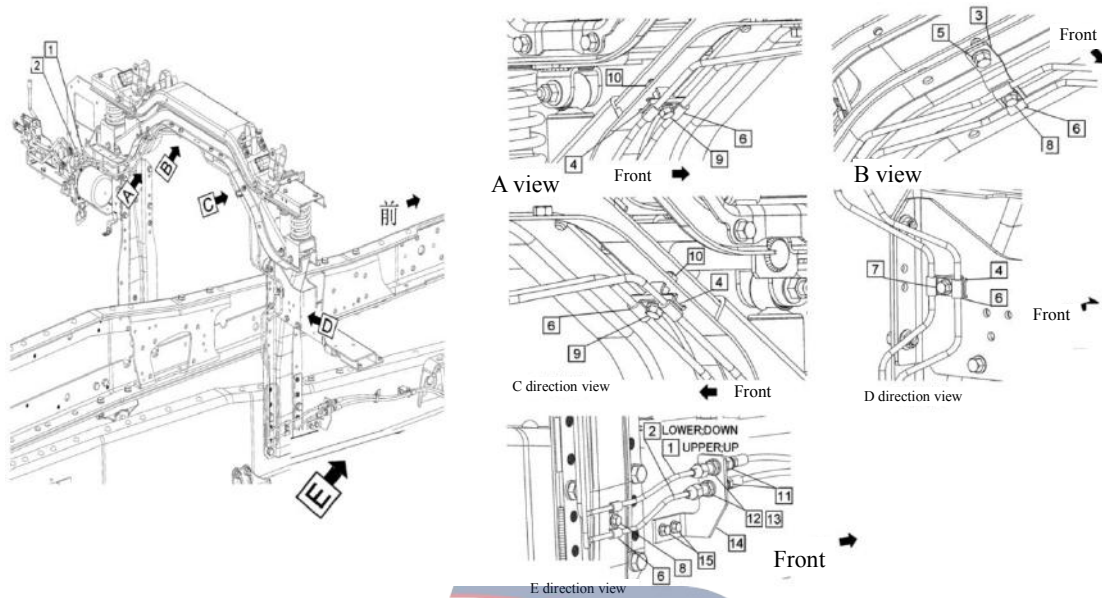

Assembly requirements:

1. Assemble parts (1)(2) (2)(4) (5) (6) (7) (7) (9) (11)(20) (11)(12) (13) (14) and (15) as shown in the figure.

Assembly details:

1. Hard pipe assembly - oil inlet

Hard pipe assembly - oil inlet (8202531-D17YZ)

2. Hard pipe assembly - oil drainage

Hard pipe assembly - oil drainage
(8202532-D17YZ)

3. Support

4. Support (3506012-117)

5. Bolt (Q1841020×1.25)

6. Clip

7. Bolt (Q1840840)

8. Bolt (Q1840820)

9. Bolt (Q1840835)

10. Nut (Q32008)

11. Connector

12. Nut (Q351C12)

13. Spring washer (Q40312)

14. Support

15. Bolt (Q1840830)

POWERSTAR

Air filter sub-assembly

High-ceiling cab assembly

Overall view

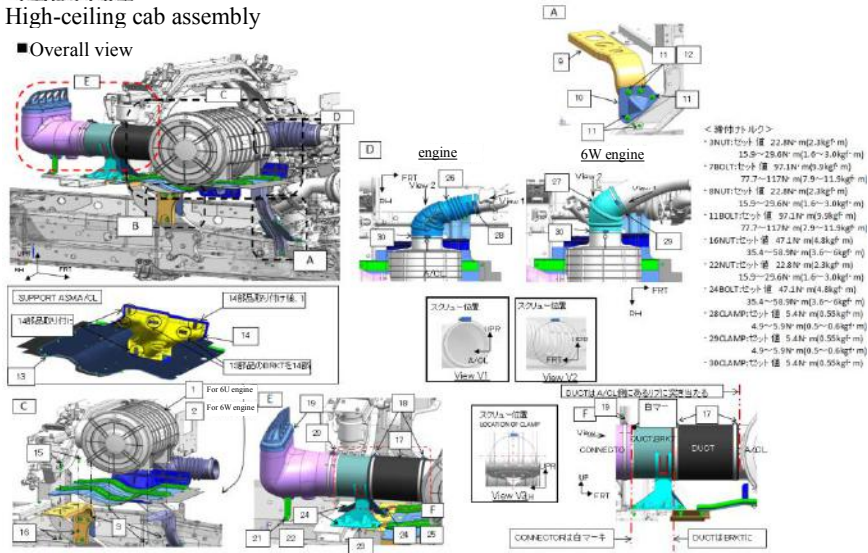

Assembly requirements:

1. Assemble parts (1)(2) (3)(3) (4) (5) (6) (7) and (8) as shown in the figure.

Assembly details:

- | | |
|--|--|
| 1. Air filter assembly | 19. Connector |
| 2. Air filter assembly (for 6W)(1109240-D17YZ) | 20. Pipe clamp (1109217-D17YZ) |
| 3. Nut (Q32008) | 21. Bolt (Q1840825) |
| 9. Support (1109313-D17YZ) | 22. Nut (Q32008) |
| 10. Support (1109314-D17YZ) | 23. Air intake device (1109516-D17YZ) |
| 11. Bolt (Q1841230(P=1.25)) | 24. Bolt (Q1841025(P=1.25)) |
| 12. Nut (Q32012(P=1.25)) | 25. Nut (Q32010T13F2(P=1.25)) |
| 13. Support assembly - air filter | 26. Rubber pipe - air filter to engine (1109215-D15YR) |
| 14. Baffle plate | 27. Rubber pipe - air filter to engine (for 6W)(1109215-D17YZ) |
| 15. Bolt (Q1841025(P=1.25)) | 28. Clip |
| 16. Nut (Q32010T13F2(P=1.25)) | 29. Pipe clamp (for 6W) |
| 17. Air intake device (1109514-D17YZ) | 30. Pipe clamp |
| 18. Pipe clamp (1109217-D17YZ) | |

Hard pipe assembly

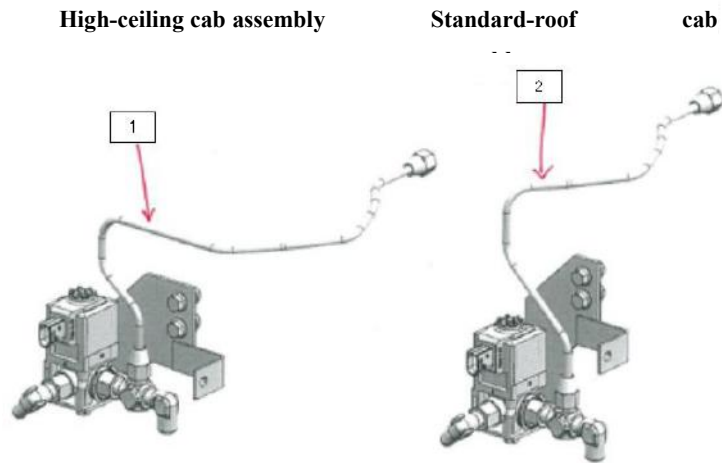

Assembly requirements:

1. Arrange the air pipe assemblies (1) or (2) as shown on the right, connect its lower end to the solenoid valve assembly connector, and also connect its upper end to the regulating valve assembly connector.
2. Tighten the connectors of both ends of the air pipe assembly (1) or (2).

Assembly details:

1. Air pipe assembly (5001651-D17YZ)
2. Air pipe assembly (5001661-D17YZ)

POWERSTAR

Gantry turnover cylinder and pull rod sub-assembly

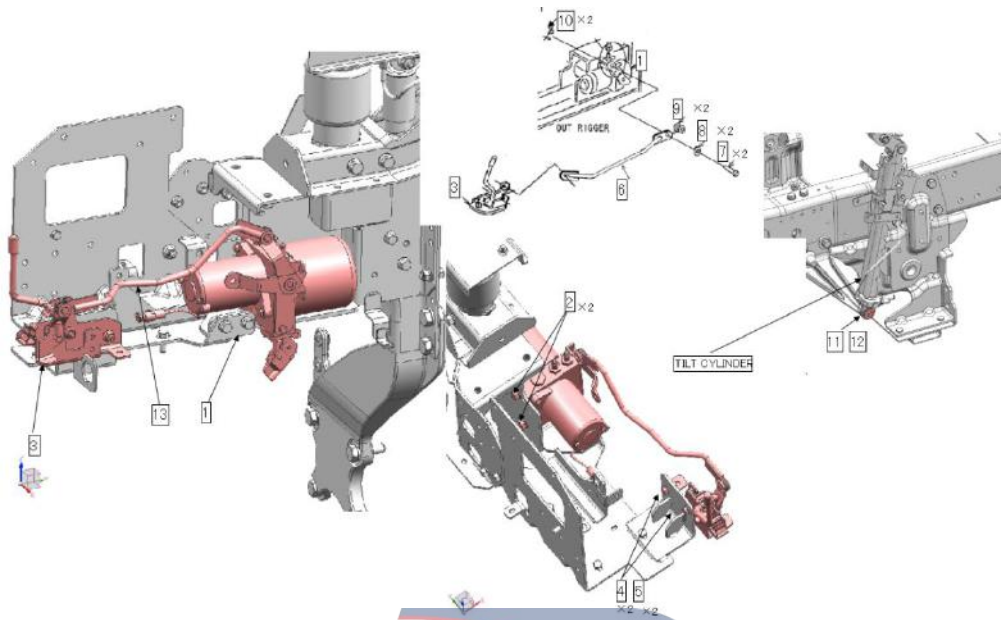

Assembly requirements:

1. Assemble parts (1)(2)(3)(4)(5)(6)(7)(8)(9)(10)(11) and (12) as shown in the figure.

Assembly details:

- | | |
|---|-------------------------|
| 1. Cab turnover pump assembly (8982373000) | 7. Pin (Q5100817) |
| 2. Bolt (Q1841016(P=1.25)) | 8. Washer (Q40208) |
| 3. Control lever (8202412-D17YZ) | 9. Liner bushing |
| 4. Bolt (Q1840820) | 10. Pin (8101194-117/C) |
| 5. Nut (Q32008) | 11. Bolt |
| 6. Drawbar assembly - turnover cylinder (8202413-D17YZ) | 12. Washer (Q40210) |

Gantry drawbar, lockout device sub-assembly

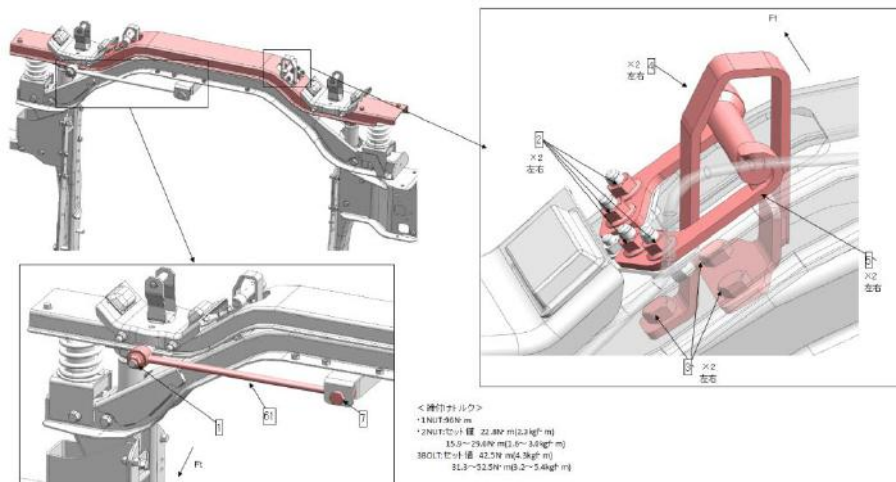

Assembly requirements:

1. Assemble parts (1)(2)(3)(4)(5)(6) and (7) as shown in the figure.
2. Tightening bolts (1) and (7) at a torque of 96 N.m.
3. Apply red inkpad oil on the heads of bolts (1) and (4).

Assembly details:

1. Bolt (Q32016T13(P=1.5))
2. Nut (Q32008)
3. Bolt (Q151B1025)
4. Locking device - top
5. Locking device
6. Connecting rod assembly
7. Assembling bolt

POWERSTAR

Gantry and frame connection

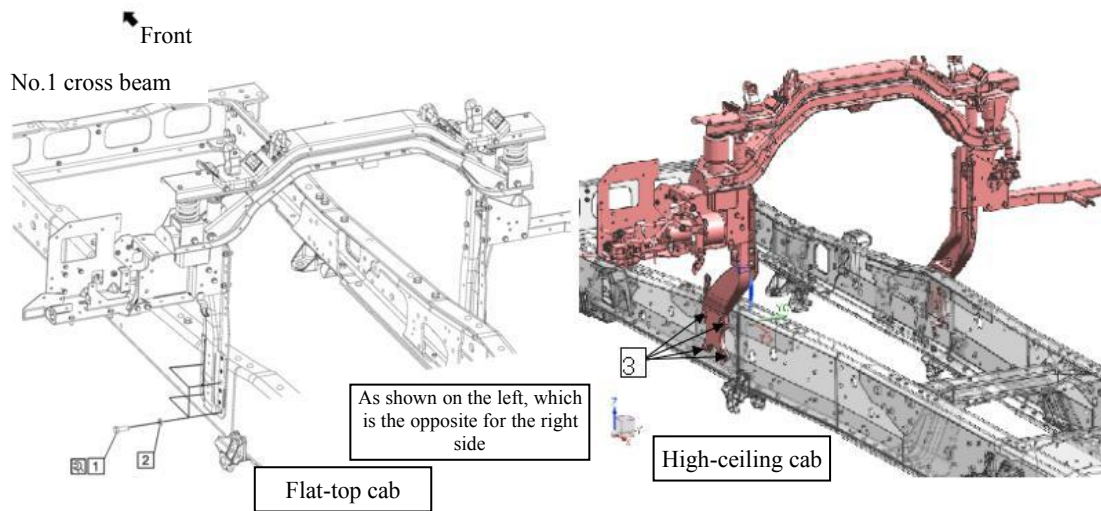

Assembly requirements:

1. As shown in the figure, the gantry assembly is lifted to the pictorial position.
2. Insert bolt (1) into spring washer (2), and let them pass through the mounting hole on the gantry, and screw the bolt into the nut hole on the frame.
3. Tighten bolt (1) at a torque of 152 N.m.
4. Apply red inkpad oil on the head of bolt (1).

Assembly details:

1. Bolt (Q151B1445T)
2. Washer (2801104-113)
3. Bolt (Q1841450)

POWERSTAR

Portal frame supports sub-assemblies (high ceiling)

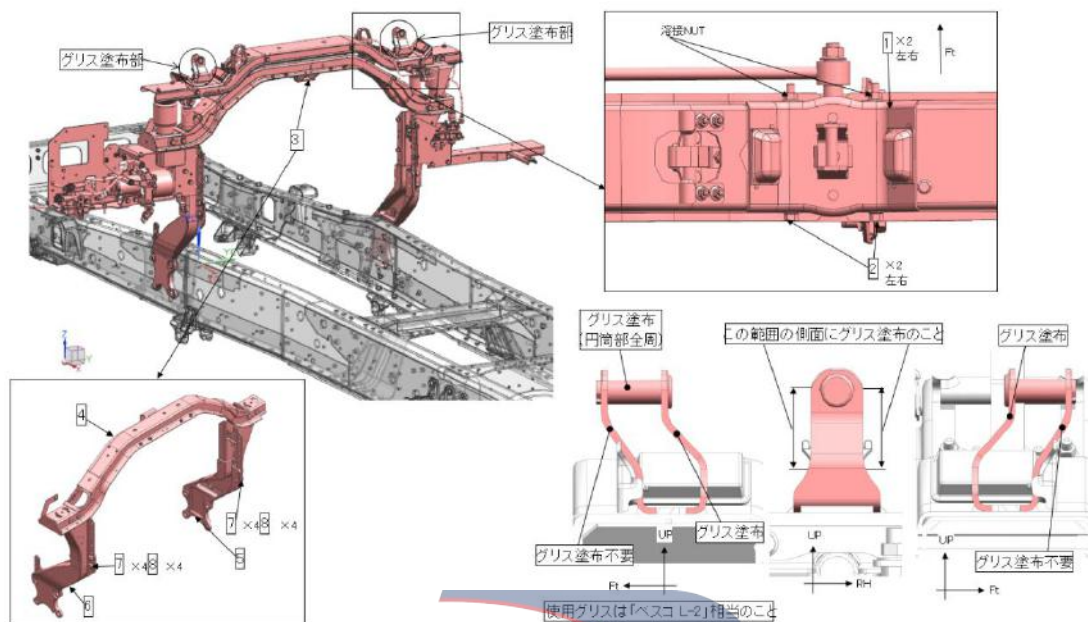

Assembly requirements:

1. Assemble parts (1),(2),(3),(4),(5),(6),(7) and (8) as shown in the figure.
2. Tighten bolt (7) at a torque of $142+28$ N.m.
3. Apply red inkpad oil on the head of bolt (7).

Assembly details:

1. Support (8202490-D17YZ)
2. Bolt (Q18410140)
3. Support assembly (5001010-D17YZ)
4. Cross beam (5001012-D17YZ)
5. Support assembly (5001015-D17YZ)
6. Support assembly (5001016-D17YZ)
7. Bolt (Q151B1425T)
8. Washer (2801104-113)

POWERSTAR

Portal frame supports sub-assemblies (flat roof)

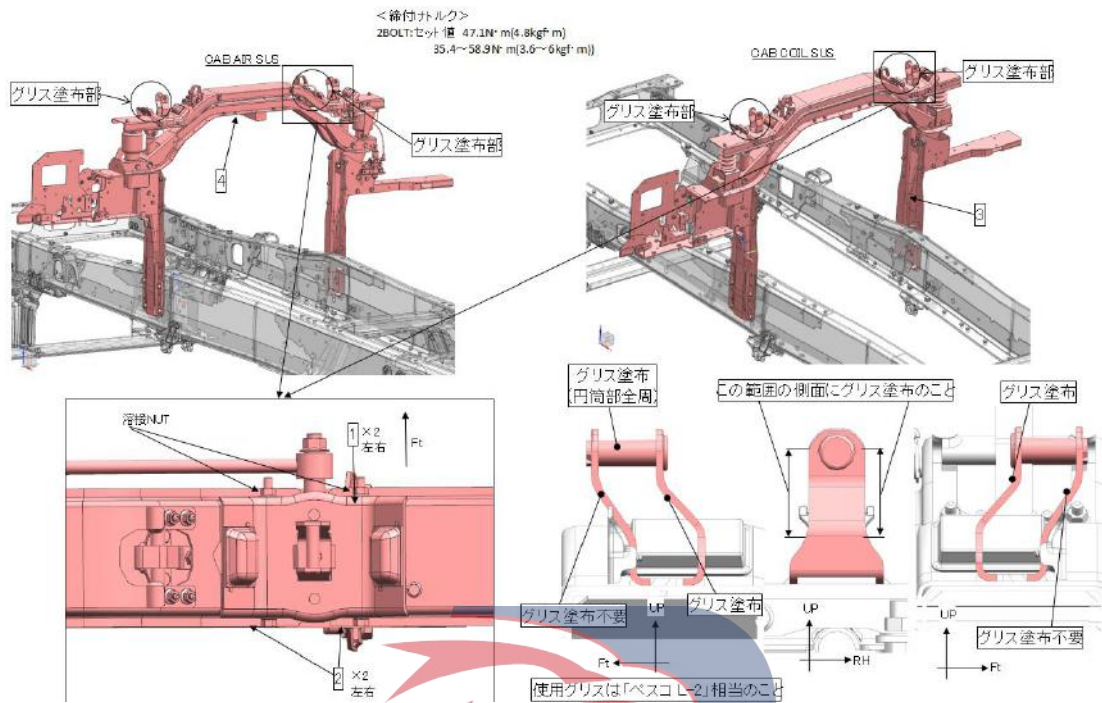

Assembly requirements:

1. Assemble parts (1)(2)(3) and (4) as shown in the figure.
2. Tighten bolt (2) at a torque of 142±28 N.m.
3. Apply red inkpad oil on the head of bolt (2).

Assembly details:

1. Support (8202490-D17YZ)
2. Bolt (Q18410140)
3. Support assembly
4. Cross beam (5001030-D17YZ)

POWERSTAR

Portal frame supports sub-assemblies (flat roof)

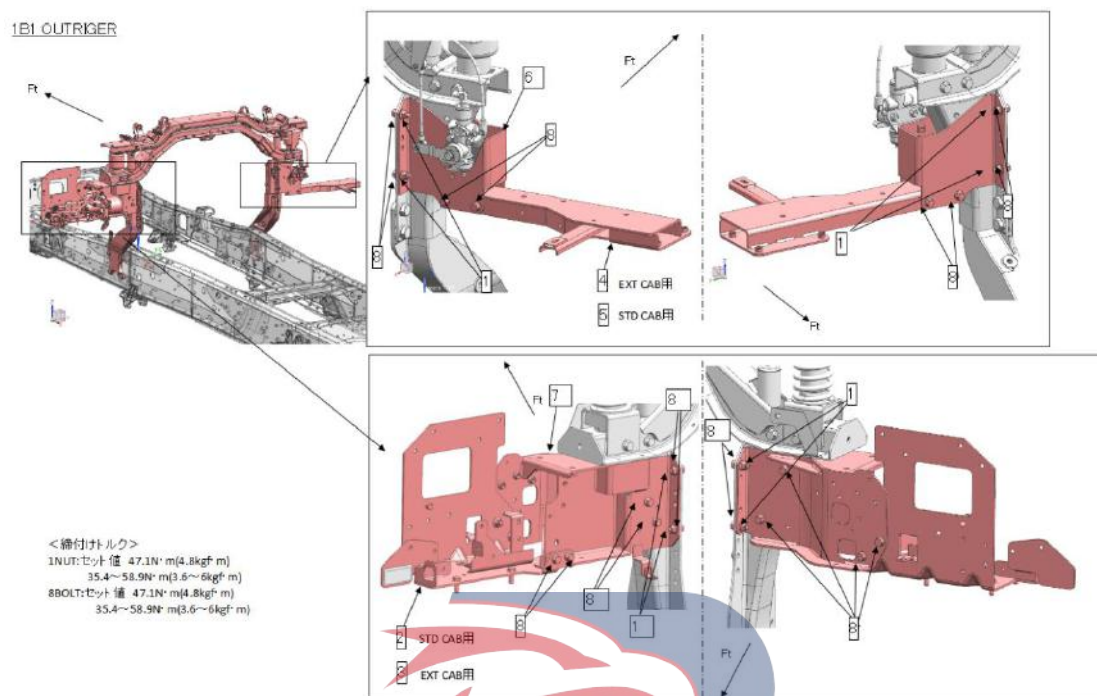

Assembly requirements:

1. Assemble parts (1),(2),(3),(4),(5),(6),(7), and (8) as shown in the figure.

Assembly details:

1. Nut (Q32010T13F2(P=1.25))
2. Support (flat roof)
3. Support (high ceiling) (5001023-D17YZ)
4. Support (high ceiling) (5001024-D17YZ)
5. Support (flat roof))
6. Support (5001024-D34EZ)
7. Support (5001025-D34EZ)
8. Bolt (Q1841025(P=1.25))

Airbag assembly

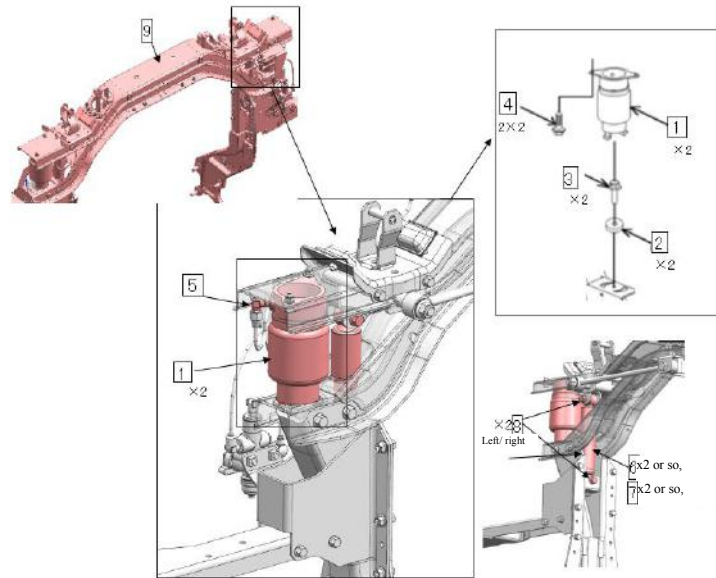

Assembly requirements:

1. Take the connector 5, and smear 8-10mm long Loctite 575# thread sealant in the longitudinal direction, starting 2-3 pitches from the lowest part of the thread.
2. Screw the sealant-applied connector (5) into the air spring assembly (1) two or three turns; then loosen it two or three turns so as to allow the sealant to be evenly smeared on the connector (5).
3. As shown in the figure, tighten the connector (5). The tightening angle shall be appropriate.
4. Take the sub-assembled air spring assembly (1) and connect its upper end to the cross beam by using the bolt (4) and connect its lower end to the portal frame support assembly by using the bolt (3) and conductor-air spring (2).
5. Tighten bolts (3) and (4).

Assembly details:

1. Air spring assembly (5002821-D17YZ)
2. Conductor-air spring
3. Bolt (Q1840820)
4. Bolt
5. Connector
6. Damper assembly (8202520-D34EZ)
7. Damper assembly (8202520-D17YZ)
8. Bolt (Q1841260T(P=1.25))
9. Support assembly (5001020-D17YZ)

Regulating valve assembly

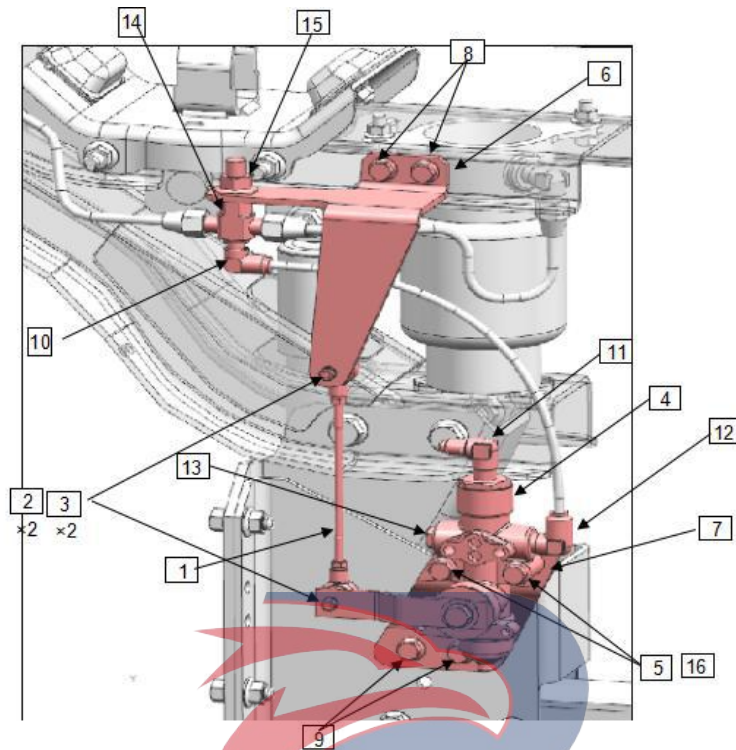

Assembly requirements:

1. Fit and fix the bracket (6), connectors (10) and (14) and bolt (15) as shown on the right.
2. Fit and fix the bracket (7), valve (4), bolt (5), nut (16) and connectors (11) (12) (13) as shown on the right.
3. Fix the sub-assembled support (6) on the bracket on the right side of the portal frame using the bolt (8) as shown in the figure.
4. Fix the sub-assembled support (7) on the bracket on the right side of the portal frame using the bolt (9) as shown in the figure.
5. Take the connecting rod assembly (1), with the nut (2) and the spring washer (3), its upper end connected to the lower mounting hole of the bracket (6) and its lower end connected to the left mounting hole of the valve assembly (4).
6. Tighten bolts (8) and (9), and nut (2).

Assembly details:

- | | |
|----------------------------|-----------------------|
| 1. Connecting rod assembly | 9. Bolt (Q1840825) |
| 2. Spring washer (Q40305) | 10. Connector |
| 3. Nut (Q340B05T13) | 11. Connector |
| 4. Valve | 12. Connector |
| 5. Bolt (0280608450) | 13. Plug |
| 6. Support | 14. Connector |
| 7. Support | 15. Nut (Q32012T13F2) |
| 8. Bolt (Q1840820) | 16. Nut (Q32008) |

Hard pipe assembly for left and right airbags

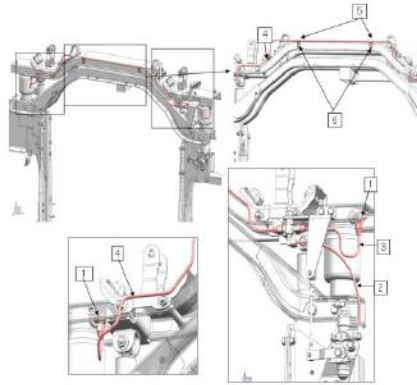

Assembly requirements:

1. Arrange air pipe assembly (4) as shown on the right. Connect the left end to the connector of left air spring assembly and connect its right end to the connector of the gantry on the right side.
2. Arrange air pipe assembly (3) as shown on the right. Connect the left end to the right connector of the gantry, and connect its right end to the connector of right air spring assembly.
3. Fix the air pipe assembly (4) with clip (5) and bolt (6) as shown on the right.
4. Tighten bolt (6) and both ends of the air pipe assemblies (3) and (4).
5. Insert the nylon tube (2) repeatedly as shown on the right to ensure that the nylon tube is inserted into place on both ends.

Assembly details:

1. Connector
2. Nylon tube
3. Air pipe assembly
4. Air pipe assembly
5. Clip
6. Bolt (Q1840820)

POWERSTAR

Urea tank hose mounting support assembly (6W)

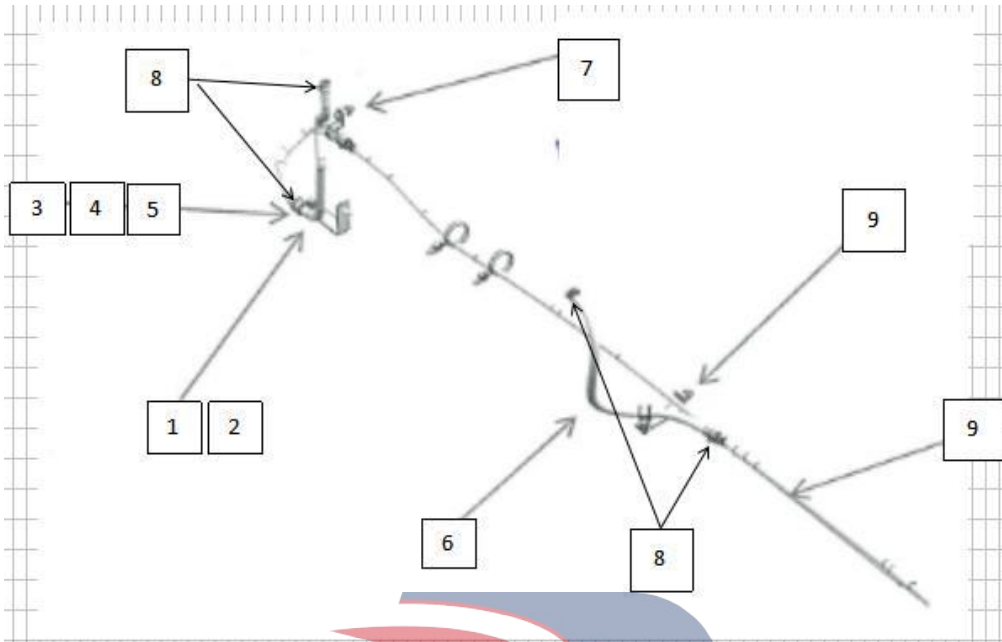

Assembly requirements:

1. As shown in the figure, take the parts (1)(2)(3)(4)(5)(6)(7)(8)(9) and assemble them.

Assembly details:

1. Support (1205083-D17YZ)
2. Bolt (Q1840825)
3. Pipe clamp
4. Bolt (Q1840820)
5. Nut (Q32008)
6. Warm water pipe (1205189-D17YZ)
7. Nylon hose assembly (1205266-D17YZ)
7. Nylon hose assembly (1205267-D15EH)
8. Circumferential clamp (1205211-D17YZ)
9. Support (3724419-117)

POWERSTAR

Urea tank sub-assembly (EXR)

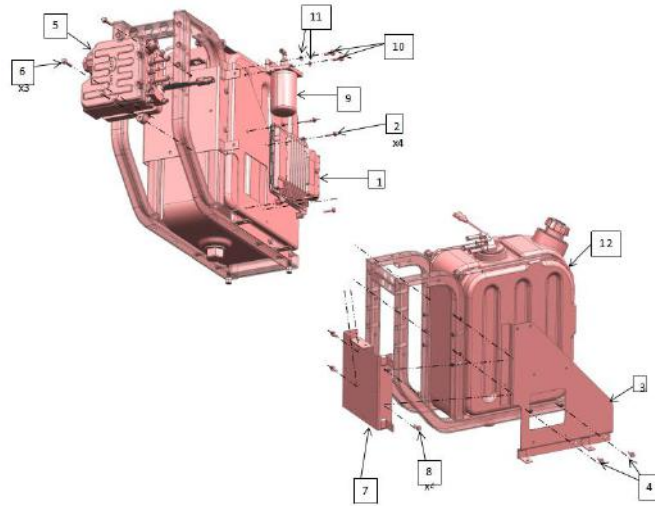

Assembly requirements:

1. Assemble parts (1)(2)(3)(4)(5)(6)(7)(8)(9)(10) and(11) as shown in the figure.

Assembly details:

1. Controller
2. Bolt (Q1840635)
3. Support (1205131-D15YZ)
4. Bolt (Q1840825)
5. Feed pump-urea (1205620-D17YZ)
6. Bolt (Q1840840)
7. Support (1205132-D15YZ)
8. Bolt (Q1840825)
9. Separator assembly (1205630-D17YZ)
10. Bolt (Q1840825)
11. Washer (Q40008)
12. Urea tank assembly (1205640-D17YZ)

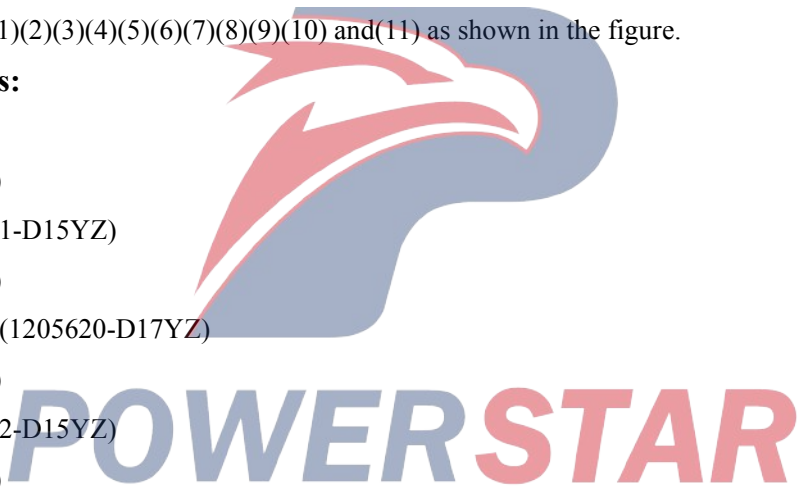

Urea tank sub-assembly (EXZ)

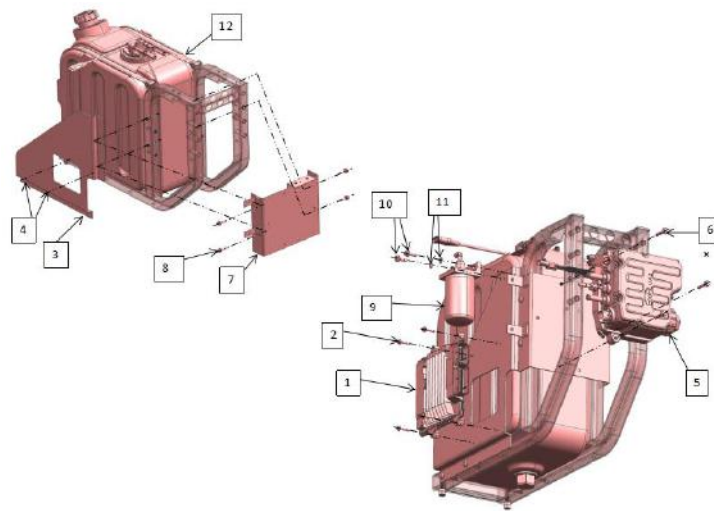

Assembly requirements:

1. Assemble parts (1)(2)(3)(4)(5)(6)(7)(8)(9)(10) and (11) as shown in the figure.

Assembly details:

1. Controller
2. Bolt (Q1840635)
3. Support (1205131-D17YZ)
4. Bolt (Q1840825)
5. Feed pump-urea (1205620-D17YZ)
6. Bolt (Q1840840)
7. Support (1205132-D17YZ)
8. Bolt (Q1840825)
9. Separator assembly (1205630-D17YZ)
10. Bolt (Q1840825)
11. Washer (Q40008)
12. Urea tank assembly (1205640-D17YZ)

The logo for POWERSTAR, featuring a stylized blue and red graphic above the word "POWERSTAR" in a bold, sans-serif font. The "P" is blue and the "O" is red, with a white swoosh underneath. The rest of the word "POWERSTAR" is in blue.

Urea tank sub-assembly connecting to the frame

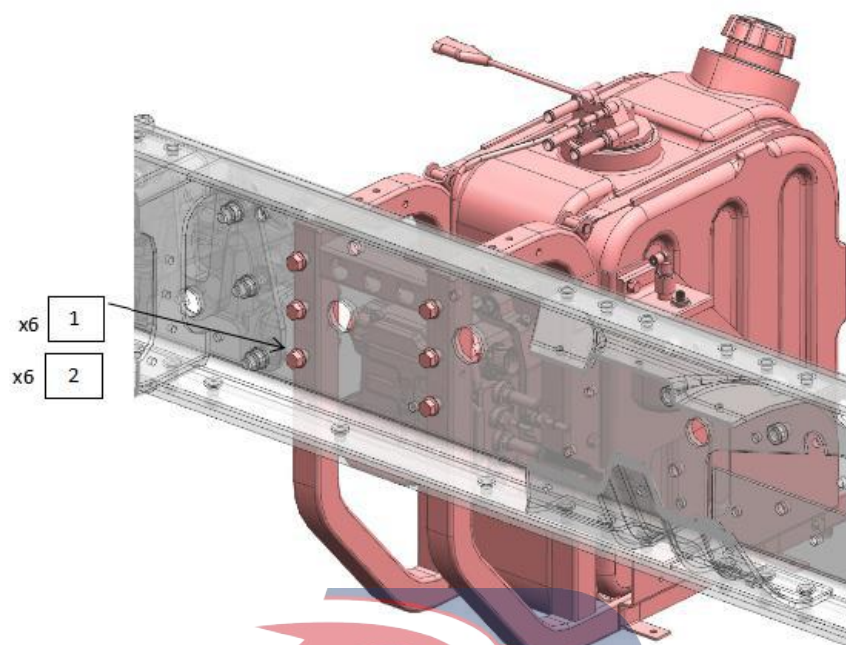

Assembly requirements:

1. Connect them with bolt (1) and nut (2).

Assembly details:

1. Bolt (Q1841270(P=1.25))
2. Nut (Q32012T13F2(P=1.25))

POWERSTAR

License plate support

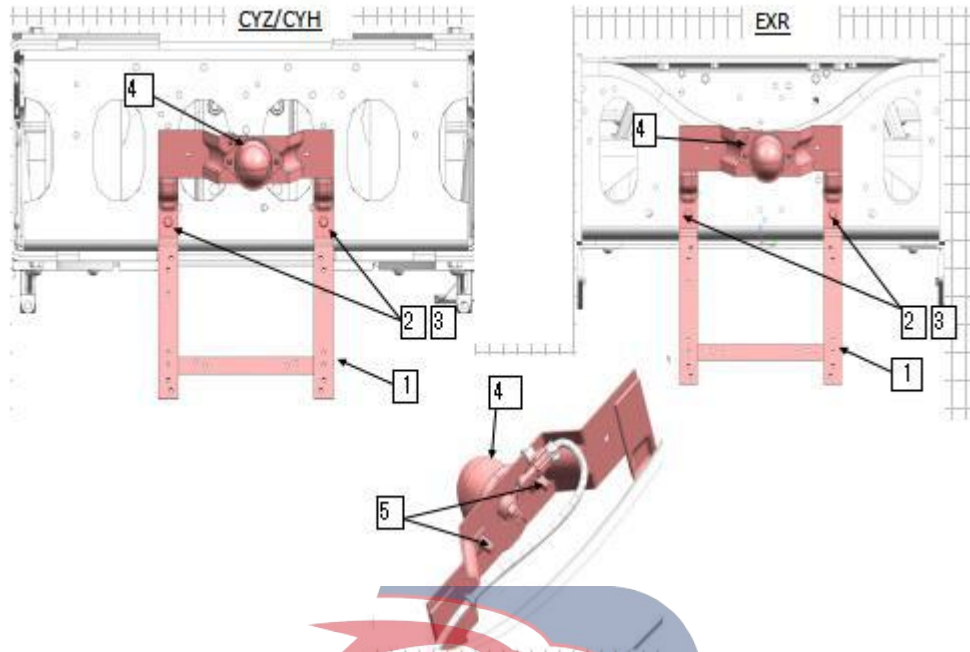

Assembly requirements:

1. Assemble parts (1)(2)(3)(4)and (5) as shown in the figure.

Assembly details:

1. Support
2. Bolt (Q1840825)
3. Nut (Q32008)
4. License plate lamp assembly (3717010-117)
5. Washer nut (6201401-26)

POWERSTAR

License plate support (EXZ type)

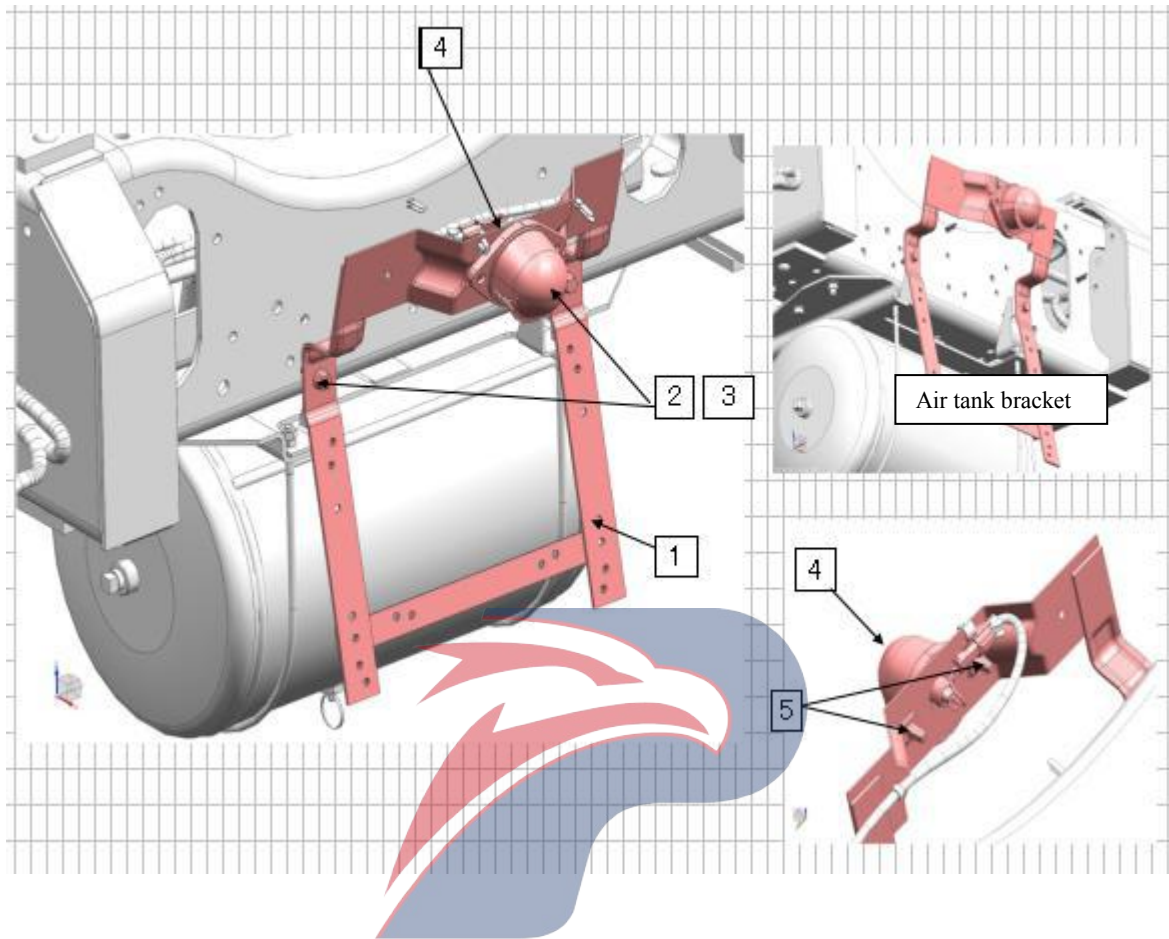

Assembly requirements:

1. Assemble (1)(2)(3)(4) and (5) as shown in the figure.

Assembly details:

1. Support
2. Bolt (Q1840825)
3. Nut (Q32008)
4. License plate lamp assembly (3717010-117)
5. Washer nut (6201401-26)

POWERSTAR

Guard rod

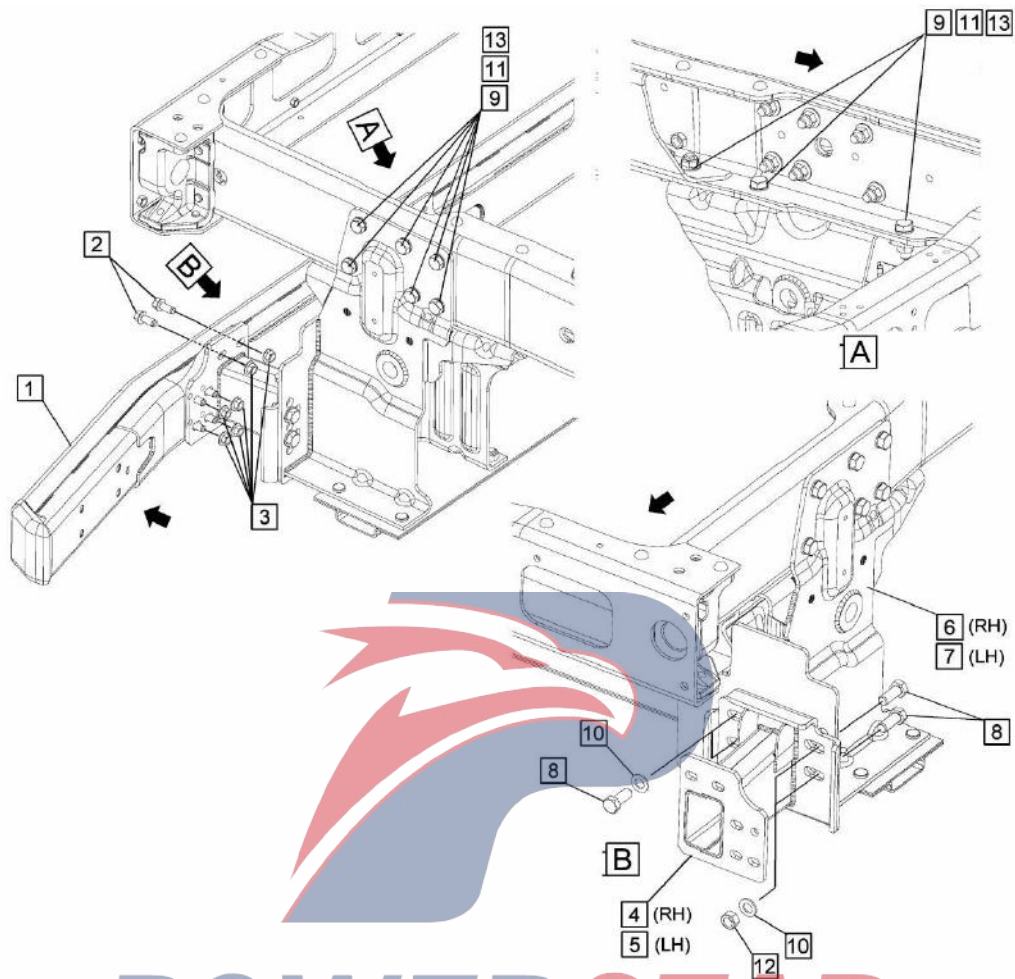

Assembly requirements:

1. Fix the supports 6 and 7 onto the frame with bolt 9, washer 11 and nut 13, and tighten the bolt at a torque of $221 \pm 44 \text{ N.m}$.
2. Fix the supports 4 and 5 onto the frames 6 and 7 with bolt 8, washer 10 and nut 12, and tighten the bolt.
3. Fix the fender rod onto the supports 4 and 5 with bolt 2 and nut 3, and tighten them.

Assembly details:

1. Anti-collision beam (2803210-D17YZ)
2. Bolt (Q1841235(P=1.25))
3. Nut (Q32012T13F2(P=1.25))
4. Support
5. Support
6. Support
7. Support
8. Bolt (Q151B1640T)
9. Bolt (Q151B1650T)
10. Washer (Q40116)
11. Washer
12. Nut (Q341B16)
13. Nut (Q32016T13(P=1.5))

Front suspension assembly (6W)

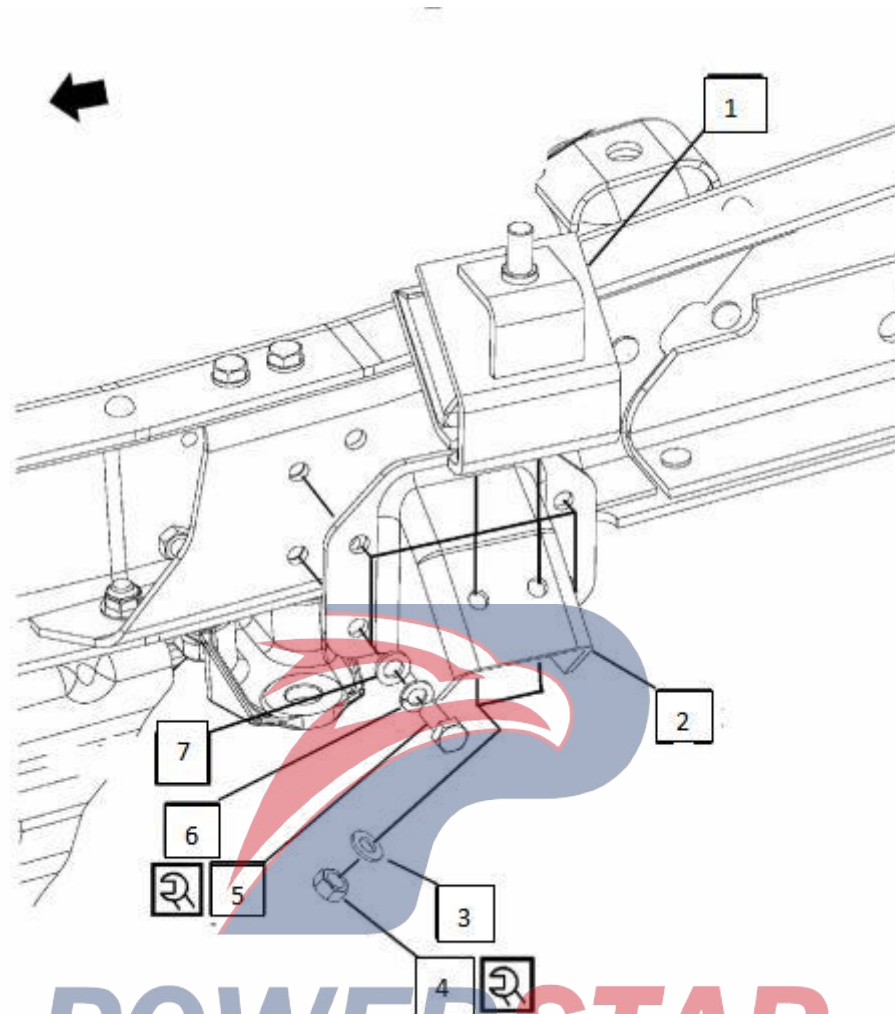

Assembly requirements:

1. Pass the front rubber pad assembly-engine ① through the bracket ② as required, and put the spring washer ③ and nut ④.
2. Tighten the nut ④ and confirm its tightening with the torque of $113\pm 15\text{N.m}$.
3. Take bolt ⑦ and put it successively through the spring washer ⑤, the washer ⑥, and the assembly of ① and ②, and tighten them successively from left to right.
4. Confirm its tightening with the torque of $157\pm 20\text{N.m}$.
5. Apply red inkpad oil on bolt ⑦ as the torque mark.

Assembly details:

1. Front rubber pad assembly-engine mounting (1532151471)
2. Right bracket (1532112720)
2. Left bracket (1006042-D17YZ)
3. Spring washer (Q40314)
4. Nut (Q341B14)
5. Bolt (Q151B1435T)

6. Spring washer (Q40514)

7. Washer (2801104-113)

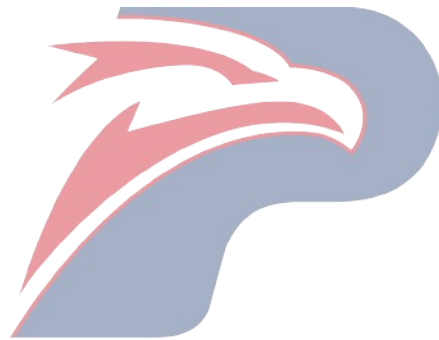

POWERSTAR

Front axle brake hose assembly (EXR/EXZ dangerous goods type)

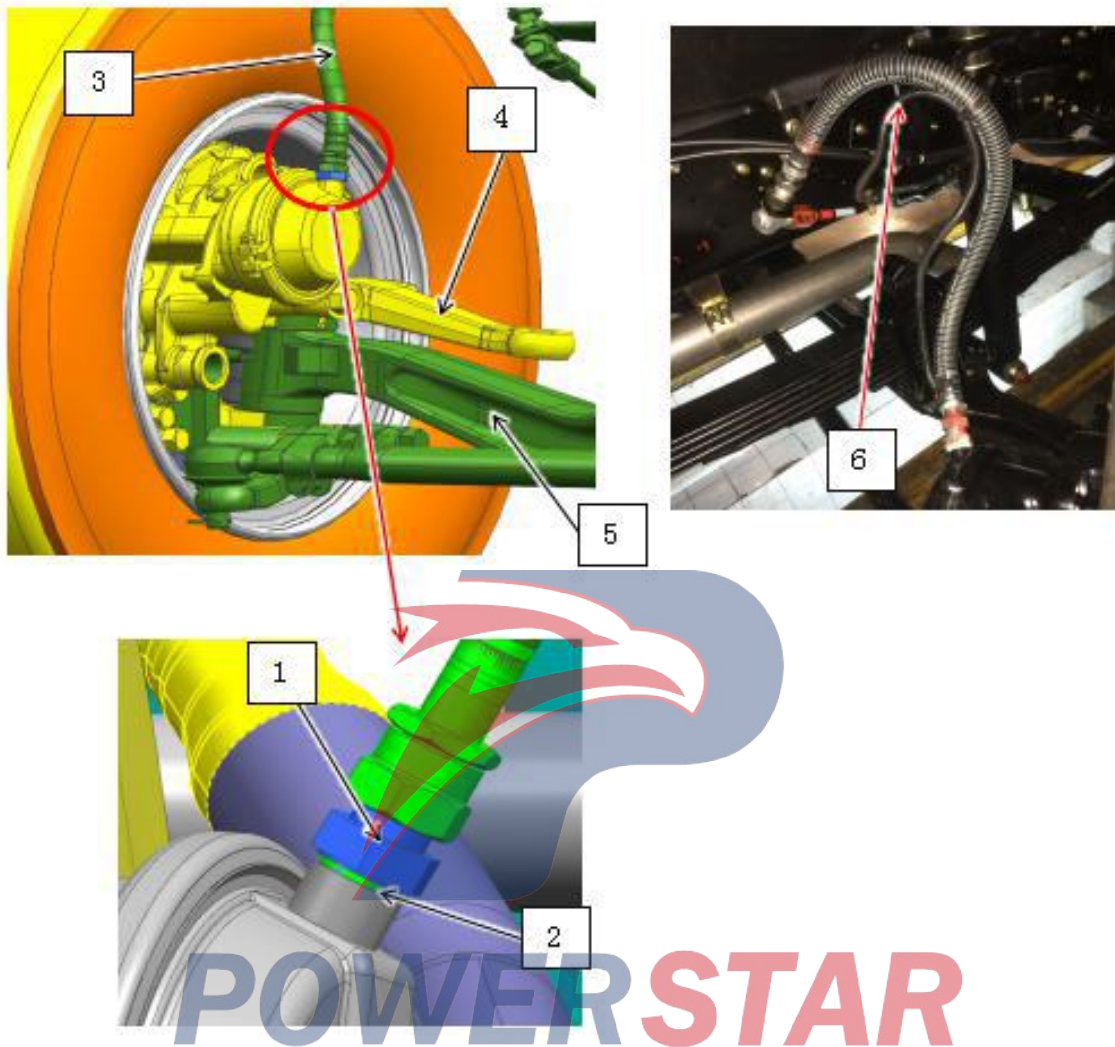

Assembly requirements:

1. Connect the hose assembly ③ as shown in the figure, tighten them with a solid wrench, and finally control the torque with a torque wrench;
2. Fix the ABS conversion harness ⑥, and tie it onto the hose assembly with the ribbon;
3. Apply Loctite 575 sealant onto the threaded end of the conversion connector ①, and connect it to the axle assembly connector, and finally tighten them with a solid wrench.

Assembly details:

1. Conversion connector
2. Washer
3. Hose assembly (3506098-CEH14)
4. Steering knuckle arm
5. Front axle assembly (3001010-CEH15)
6. ABS conversion harness

Front brake valve assembly

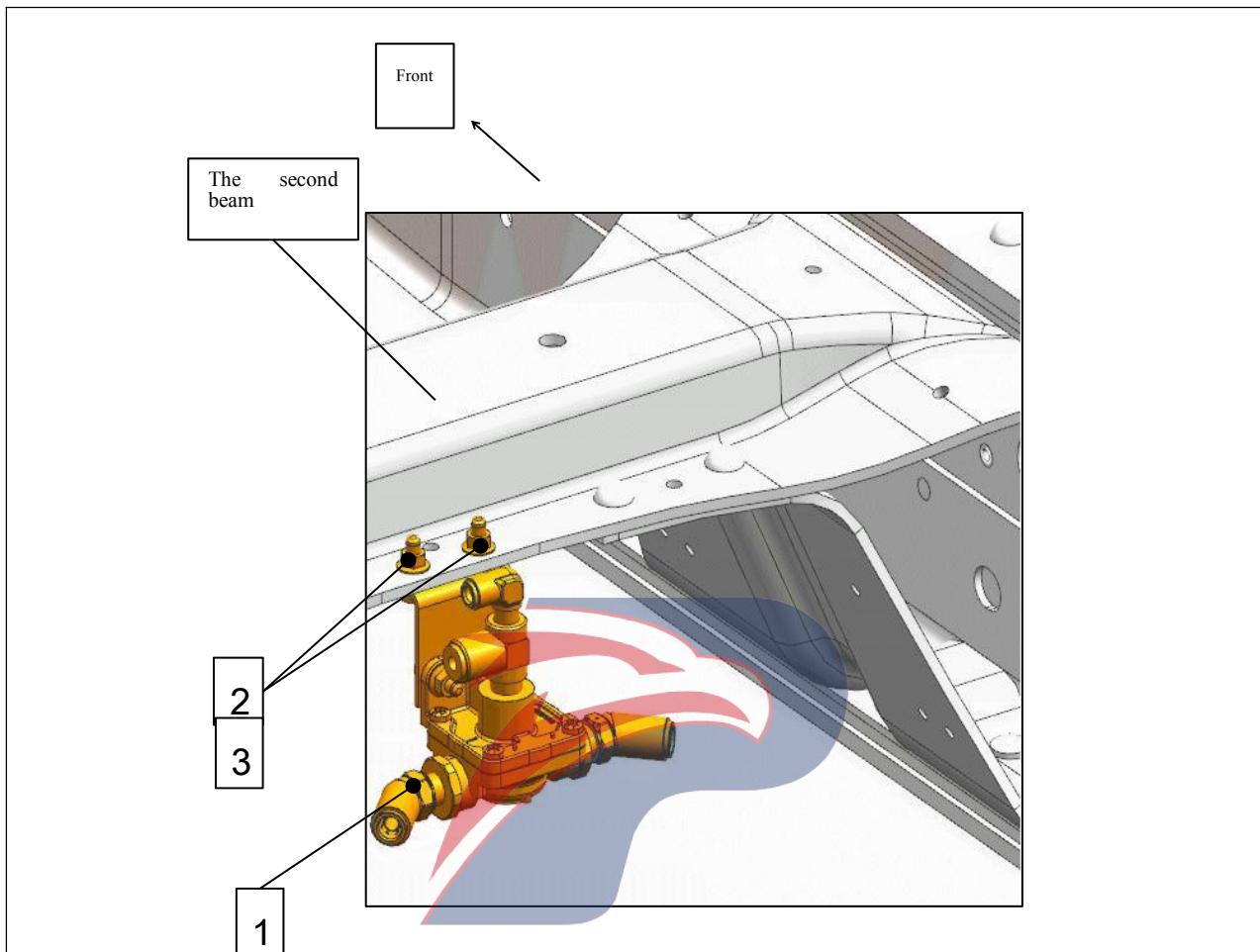

Assembly requirements:

1. As shown in the figure, take the valve assembly (1), put the bolt (3) through the upper mounting hole of the valve assembly (1) and the corresponding hole in the frame, and put on the nut (2) by 2~3 pitches.
2. Tighten the nut(2)

Assembly details:

1. Quick release valve assembly (8974339230)
2. Nut_(Q32008)
3. Bolt_(Q1840825)

Fuel filter sub-assembly

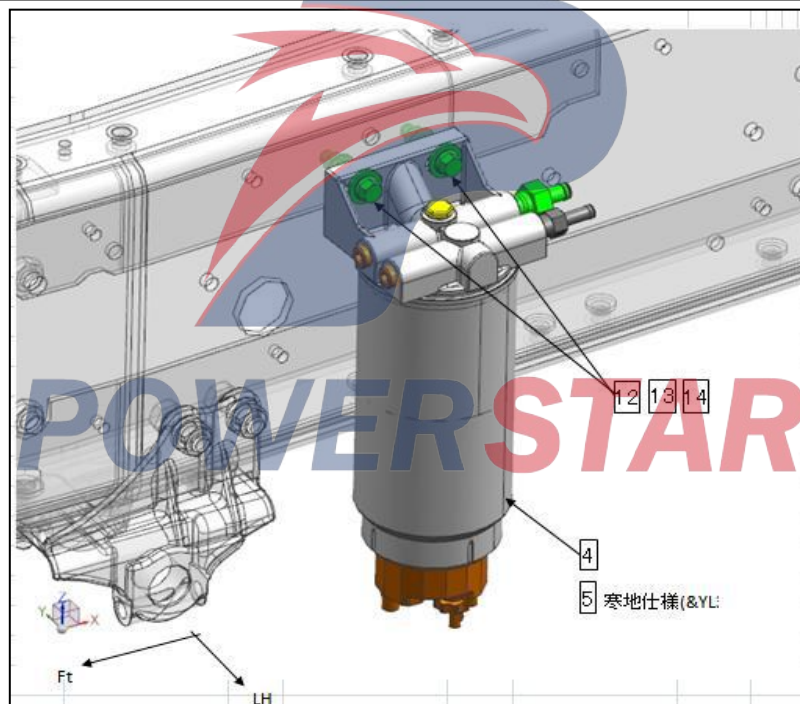
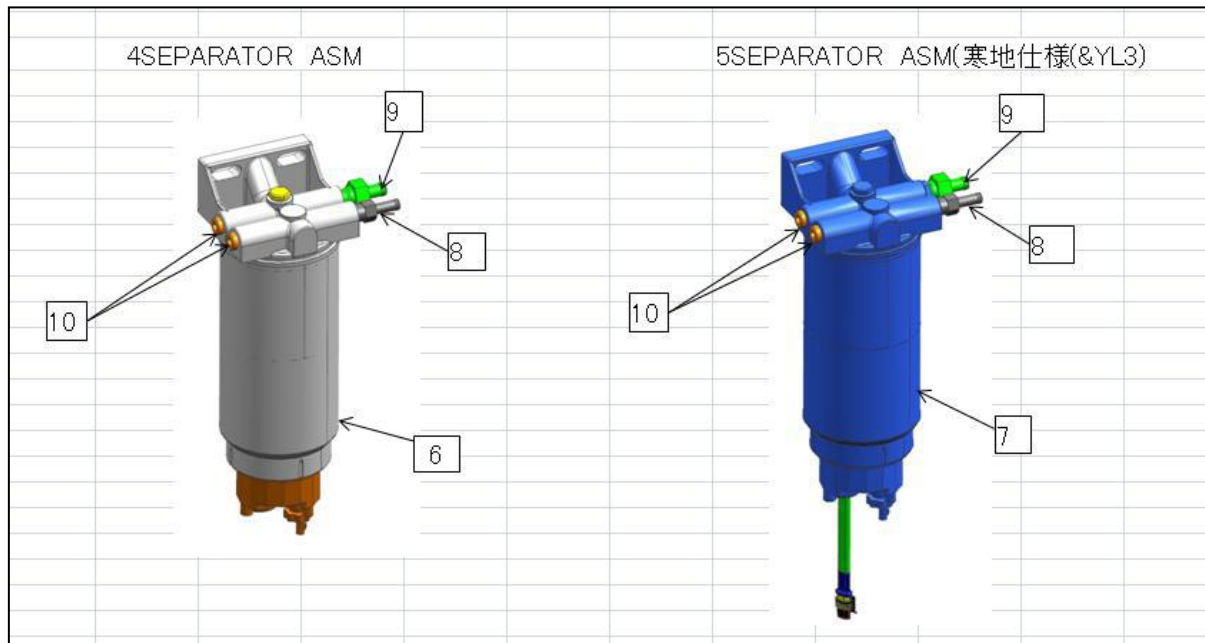

<締付けトルク>

- ・3NUT:セット値 22.8N・m(2.3kgf・m)
15.9~29.6N・m(1.6~3.0kgf・m)
- ・14NUT:セット値 47.1N・m(4.8kgf・m)
35.4~58.9N・m(3.6~6kgf・m)
- ・19NUT:セット値 22.8N・m(2.3kgf・m)
15.9~29.6N・m(1.6~3.0kgf・m)
- ・20NUT:セット値 47.1N・m(4.8kgf・m)
35.4~58.9N・m(3.6~6kgf・m)

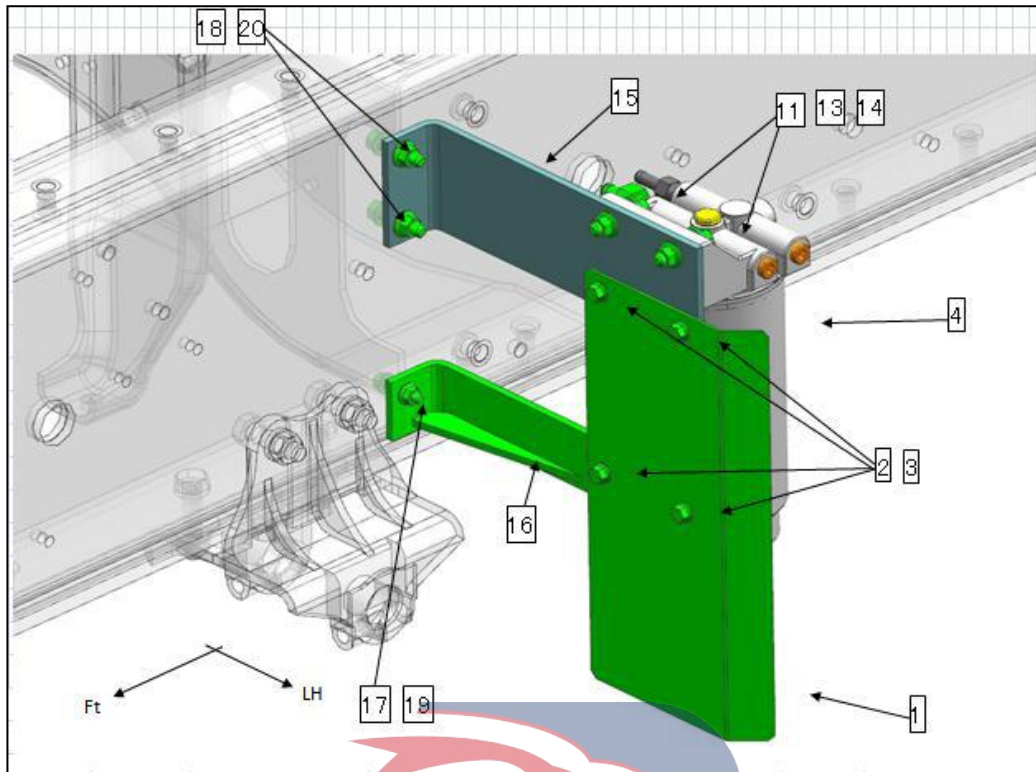

Assembly requirements:

1. Insert bolt ⑤ into washer ⑥, oil-water separator ① and fastening bolt ⑦.
2. Apply sealant to connectors (8) and (9) and tighten them at a torque of $39 \pm 5 \text{ N.m}$

Assembly details:

1. Protection-oil-water separator 1104151-D15EH
2. Bolt Q1840820
3. Nut Q32008
4. Oil-water separator sub-assembly
5. Oil-water separator sub-assembly 1104020-D17YZ
6. Oil-water separator
7. Oil-water separator 1104030-D17YZ
8. Connector
9. Connector
10. Plug 1
11. Bolt Q1841040(P=1.25)
12. Bolt Q1841050(P=1.25)
13. Washer Q40110
14. Nut Q32010(P=1.25)
15. Support 1104057-D15EH
16. Support 1104158-D15EH
17. Bolt Q1840830
18. Bolt Q1841040(P=1.25)
19. Nut Q32008
20. Nut Q32010(P=1.25)

POWERSTAR

Front axle assembly of hazardous goods chassis with disc brake (EXR、EXZ)

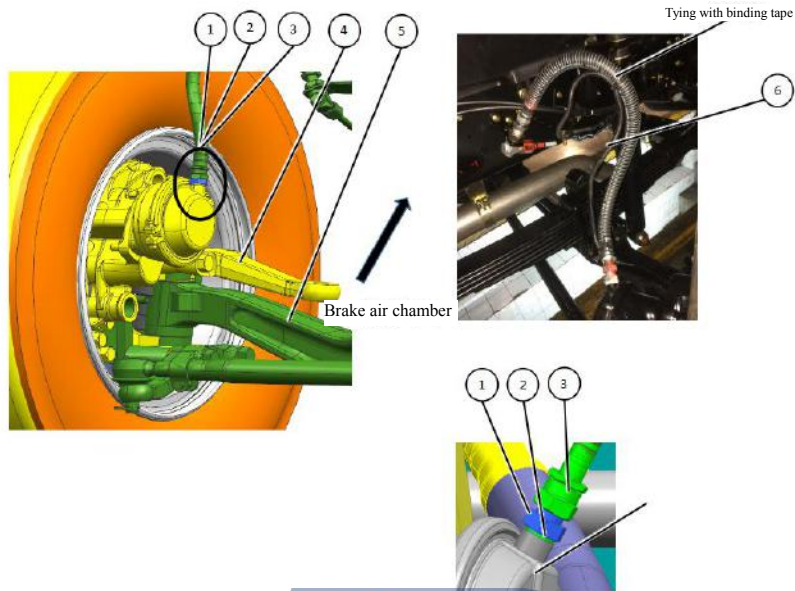

Assembly requirements:

1. Assemble parts (1)(2)(3)(4)(5) and (6) as shown in the figure.

Assembly details:

1. Adapter
2. Washer
3. Hose assembly (3506098-CEH14)
4. Steering knuckle arm
5. Front axle assembly (3001010-CEH15)
6. ABS conversion harness

POWERSTAR

Front exhaust pipe assembly for hazardous goods (EXZ)

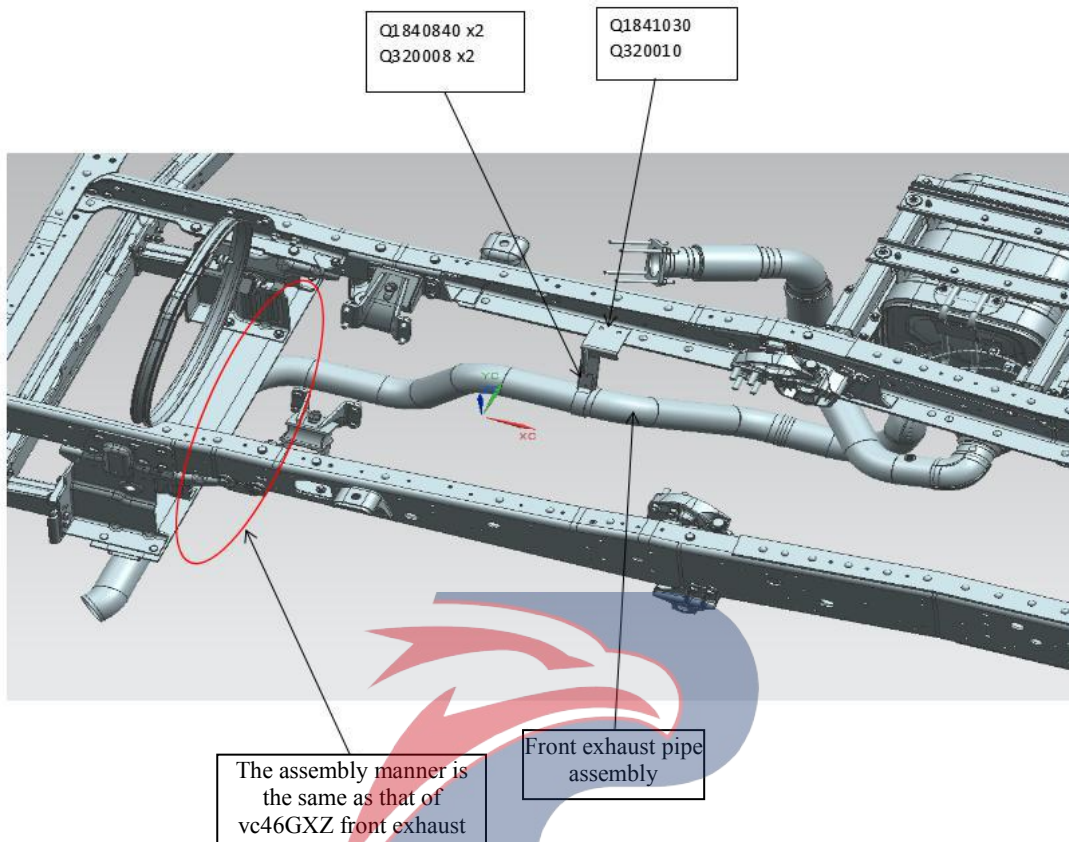

Assembly requirements:

1. Assemble parts (1) (2) (3) (4) (5) and (6) as shown in the figure.

Assembly details:

1. Front exhaust pipe assembly (203940-D17YZ)
2. Support assembly (1203941-D17YZ)
3. Bolt (Q1840840)
4. Nut (Q32008)
5. Bolt (Q1841030)
6. Nut (Q32010)

Transmission harness fixing

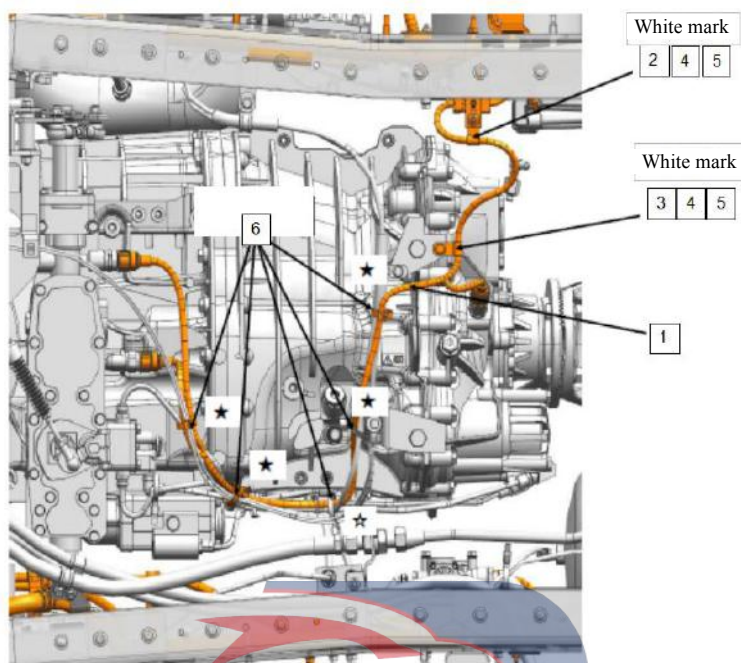

Assembly requirements:

1. Fix the harness-transmission (1) with parts (1)(2)(3)(4)(5) and (6) as shown on the right.

Assembly details:

1. Harness-transmission (3724040-D34EZ)
2. Clip (3724139-D17YZ)
3. Clip (3724139-D17YZ)
4. Bolt (Q1840820)
5. Nut (Q32008)
6. Binding tape

POWERSTAR

Rear frame segment's right wiring harness assembly

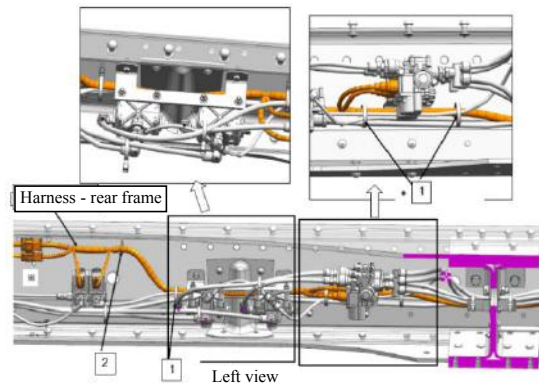

Assembly requirements:

1. Take the parts (1) and (2) and fix the wiring harness to the rear segment of the frame as shown in the figure.

Assembly details:

1. Binding tape
2. Binding tape (3703235-117/C)

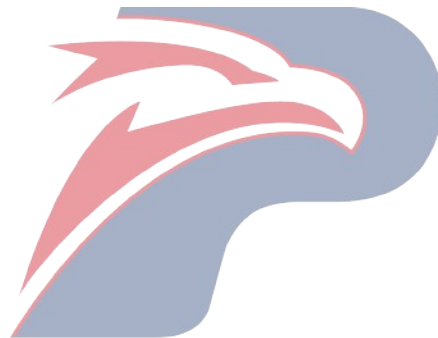

POWERSTAR

Rear frame segment's right wiring harness assembly

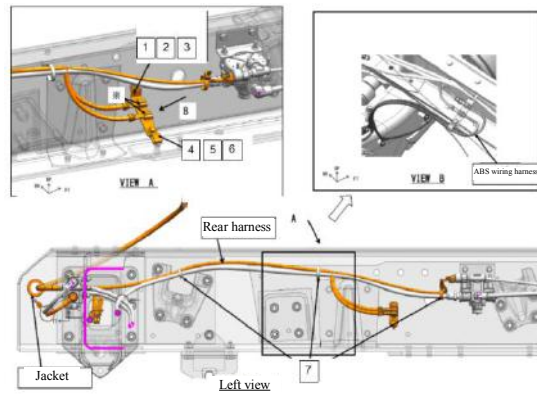

Assembly requirements:

1. Take the parts (1) and (2) and fix the wiring harness to the rear segment of the frame as shown in the figure.

Assembly details:

1. Support (3724324-D17YZ)
2. Bolt (Q1840825)
3. Nut (Q32008)
4. Clip
5. Bolt (Q1840820)
6. Nut (Q32008)
7. Binding tape

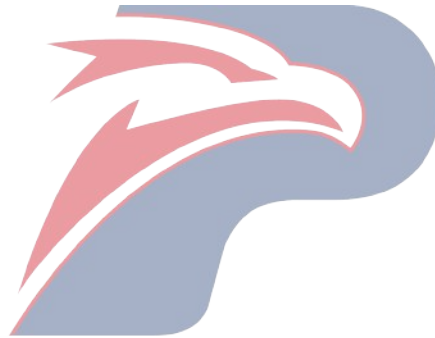

POWERSTAR

Rear frame segment's right wiring harness assembly

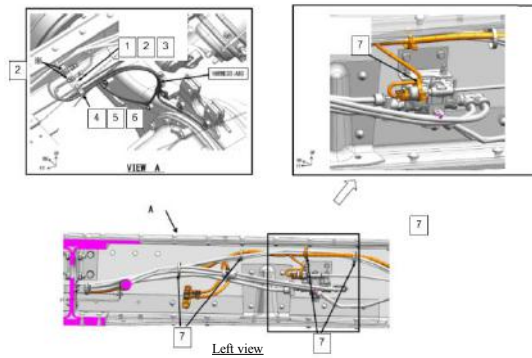

Assembly requirements:

1. Take the parts (1) and (2) and fix the wiring harness to the rear segment of the frame as shown in the figure.

Assembly details:

1. Support (3724324-D17YZ)
2. Bolt (Q1840825)
3. Nut (Q32008)
4. Clip
5. Bolt (Q1840820)
6. Nut (Q32008)
7. Binding tape

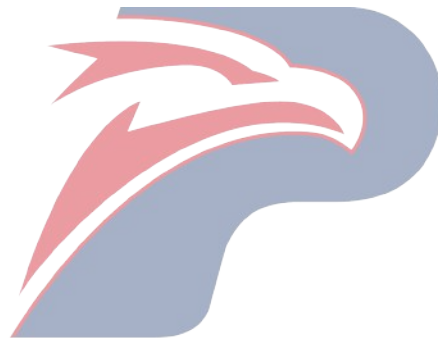

POWERSTAR

Front frame segment's right wiring harness assembly

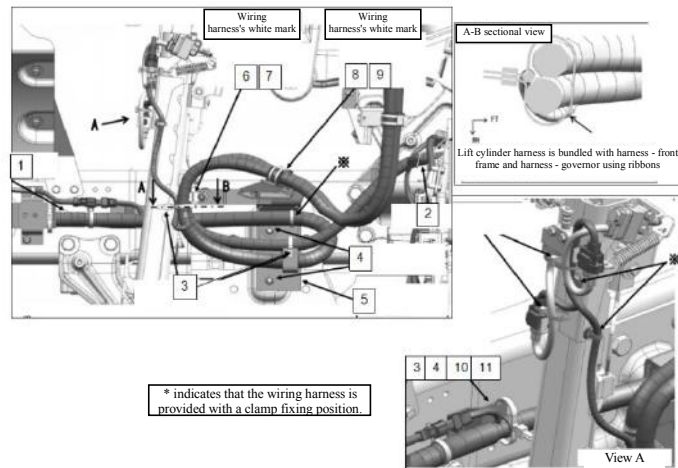

Assembly requirements:

1. Fix the harness-front frame (1) and harness-governor (2) onto the position as shown on the right with parts (3)(4)(5)(6)(7)(8)(9)(10)(11).

Assembly details:

1. Wiring harness–front frame segment
2. Wiring harness-speed regulator
3. Binding tape
4. Nut (Q32008)
5. Support (3724329-D17YZ)
6. Clip
7. Nut (Q32008)
8. Clip (3206429-D17YZ)
9. Bolt (Q1840820)
10. Support
11. Bolt (Q1840835)

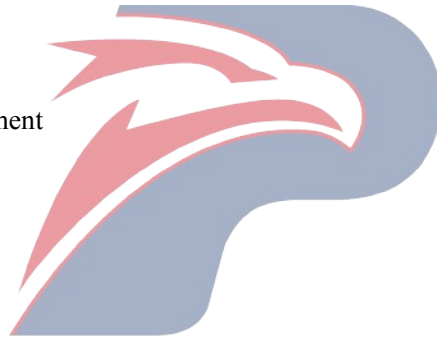

POWERSTAR

Front frame segment's right wiring harness assembly

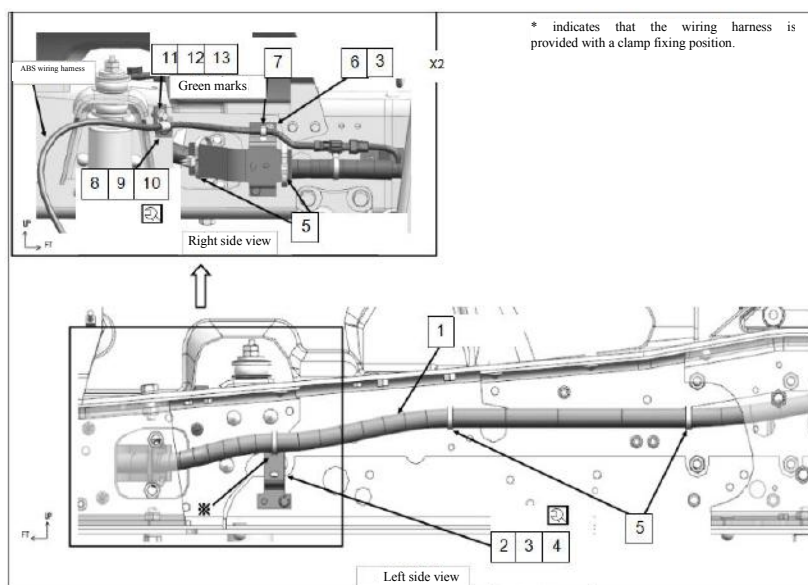

Assembly requirements:

1. Fix the harness-front frame (1) onto the position as shown on the right with parts (2)(3)(4)(5)(6)(7)(8)(9)(10)(11)(12)and (13).

Assembly details:

1. Wiring harness-front frame segment
2. Support
3. Bolt (Q1840830)
4. Nut (Q32008)
5. Binding tape
6. Support (3724330-D17YZ)
7. Clip
8. Support (3724321-D17YZ)
9. Bolt (Q1840820)
10. Nut (Q32008)
11. Clip
12. Bolt (Q1840820)
13. Nut (Q32008)

POWERSTAR

Fit the harness on the right side of the middle frame

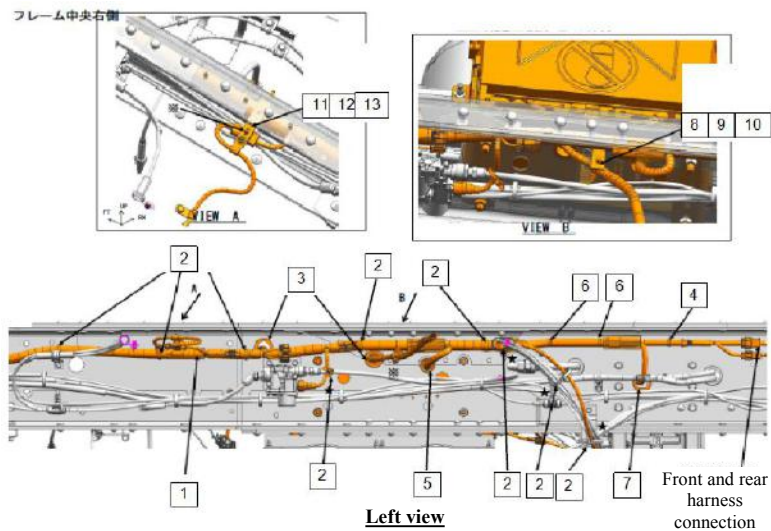

Assembly requirements:

1. Fix the harness-front frame (1) onto the position as shown on the right with parts (2)(3)(4)(5)(6)(7)(8)(9)(10)(11)(12) and (13).

Assembly details:

1. Wiring harness-front frame segment
2. Binding tape
3. Rubber lining
4. Clip (3703235-117/C)
5. Rubber lining
6. Binding tape (3724133-D17YZ)
7. Rubber lining
8. Support
9. Bolt (Q1840830)
10. Nut (Q32008)
11. Support
12. Bolt (Q1840835)
13. Nut (Q32008)

POWERSTAR

Air reservoir harness fixing

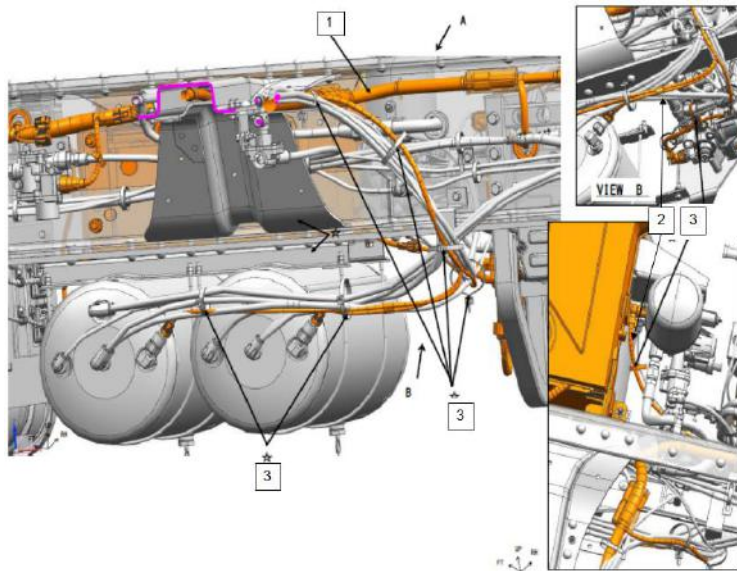

Assembly requirements:

1. Connect the harness-air reservoir (2) to harness-front frame (1) plug and fix them with ribbon (3) as shown on the right.

Assembly details:

1. Harness-front frame segment
2. Harness-Air reservoir (3724620-D17YZ)
3. Binding tape



POWERSTAR

Front headlamp wiring harness fixing

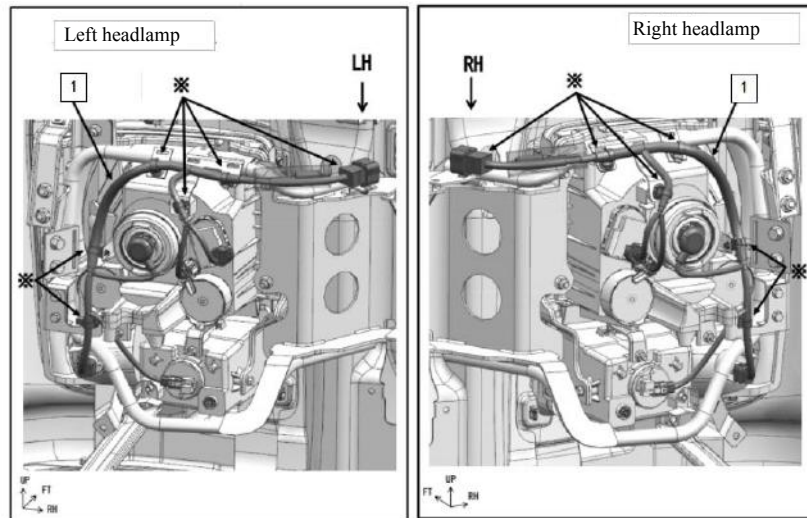

* indicates that the wiring harness is provided with a clamp fixing position.

Assembly requirements:

1. Fix the headlamp wiring harness (1) as shown in the figure.

Assembly details:

1. Headlamp wiring harness (3724010-D17YZ)

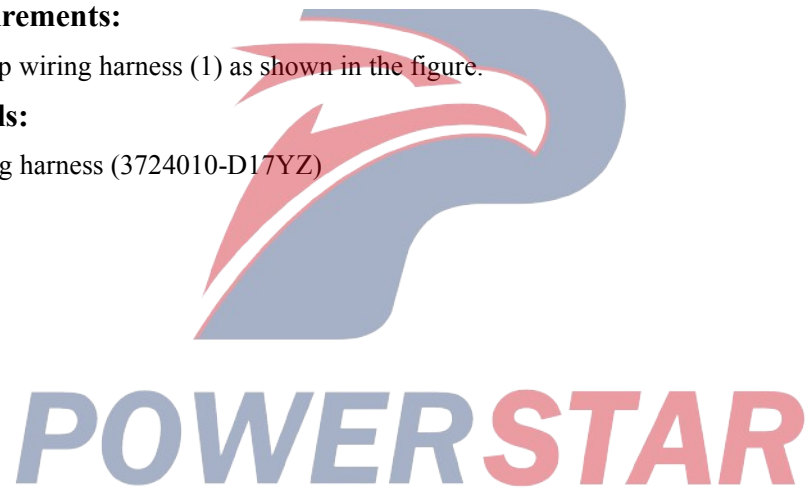

Front headlamp wiring harness fixing

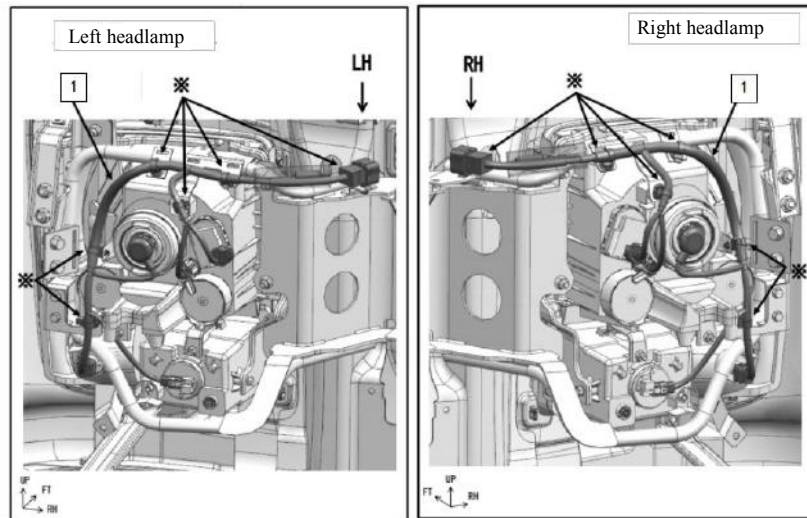

* indicates that the wiring harness is provided with a clamp fixing position.

Assembly requirements:

1. Fix the headlamp wiring harness (1) as shown in the figure.

Assembly details:

1. Headlamp wiring harness (3724010-D17YZ)

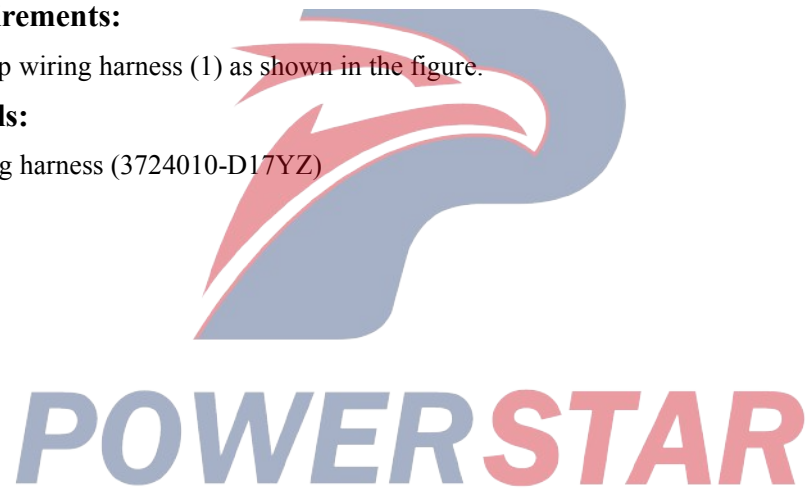

2nd-beam harness fixing

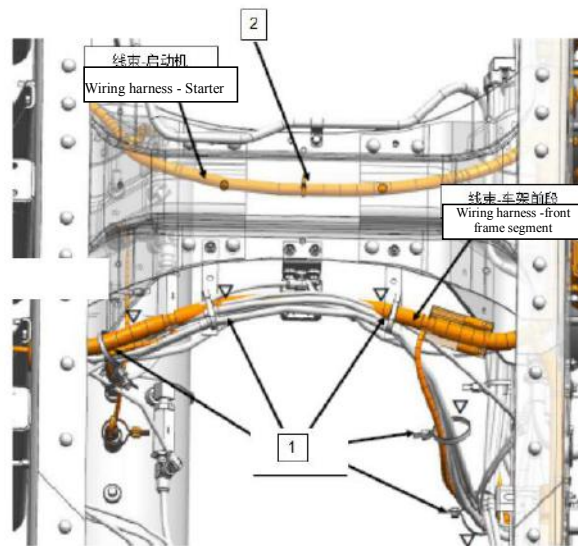

* indicates that the wiring harness is provided with a clamp fixing position.

Assembly requirements:

1. Fix the starter harness and front frame harness with parts (1) and (2) as shown on the right.

Assembly details:

1. Clip (3703235-117/C)
2. Binding tape



POWERSTAR

Generator harness fixing (6W)

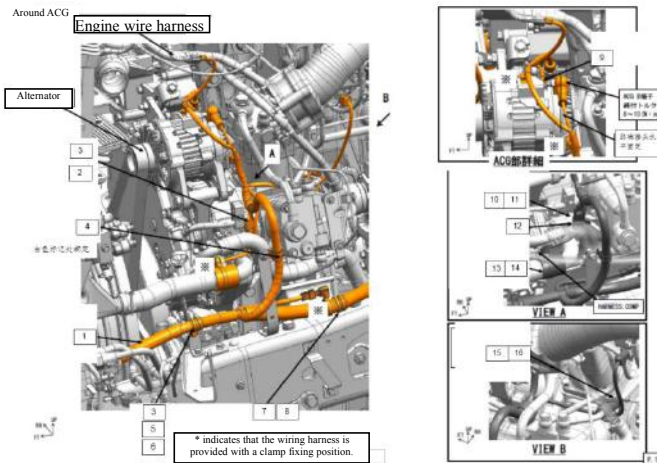

Assembly requirements:

1. Assemble parts (1) to (16) as shown in the figure.

Assembly details:

- | | |
|-----------------------------------|-----------------------------------|
| 1. Wiring harness-speed regulator | 9. Bolt (Q1840610) |
| 2. Clip | 10. Support (3724323-D17YZ) |
| 3. Bolt (Q1840820) | 11. Bolt (Q1840812) |
| 4. Clip | 12. Clip (3724551-803) |
| 5. Clip (3509065-P301) | 13. Rubber gasket (3724137-D17YZ) |
| 6. Nut (Q32008) | 14. Clip (3703237-117/C) |
| 7. Clip (3724566-803) | 15. Rubber gasket (3724136-D17YZ) |
| 8. Bolt (Q1840835) | 16. Clip (1101421-803) |

POWER STAR

Harness fixing of rear combination lamps

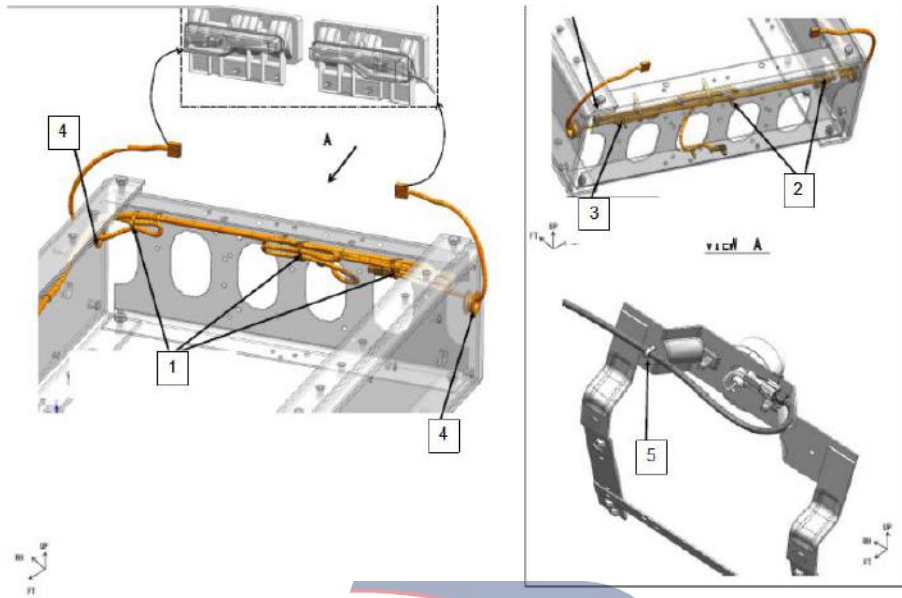

Assembly requirements:

1. Fix the harness of rear combination lamps with parts (1)(2)(3)(4) and (5) as shown on the right.

Assembly details:

1. Binding tape (1101421-803)
2. Clip (3703234-117/C)
3. Clip (3703219-117/C)
4. Jacket
5. Clip



POWERSTAR

Harness fixing of cab front panel

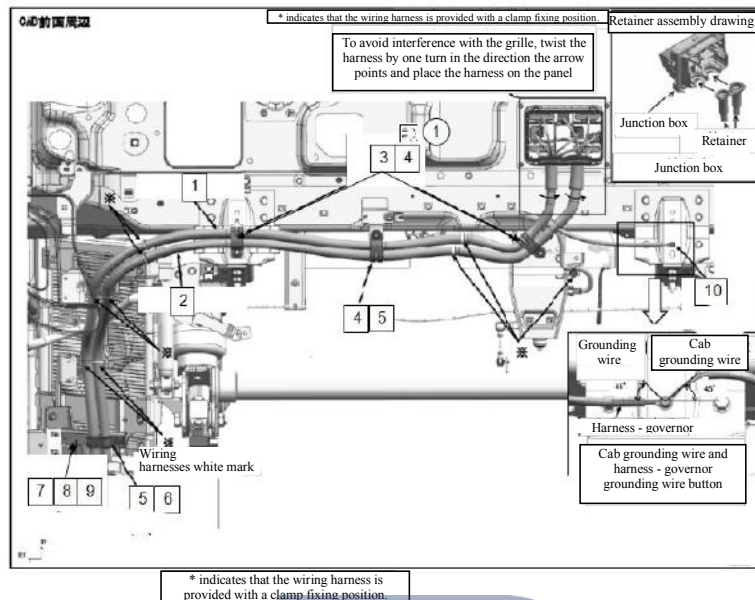

Assembly requirements:

1. Fix the parts (1) and (2) onto the position of the cab with parts (3)(4)(5)(6)(7)(8)(9)(10) as shown on the right.

Assembly details:

1. Wiring harness-front frame segment
2. Wiring harness-speed regulator
3. Clip (8101149-D17YZ)
4. Nut (Q320008)
5. Bolt (Q1840820)
6. Clip (3206429-D17YZ)
7. Support
8. Bolt (Q1840820)
9. Nut (Q320008)
10. Bolt (3703143-D17YZ)

POWERSTAR

Harness assembly on the right side of the gantry (6W)

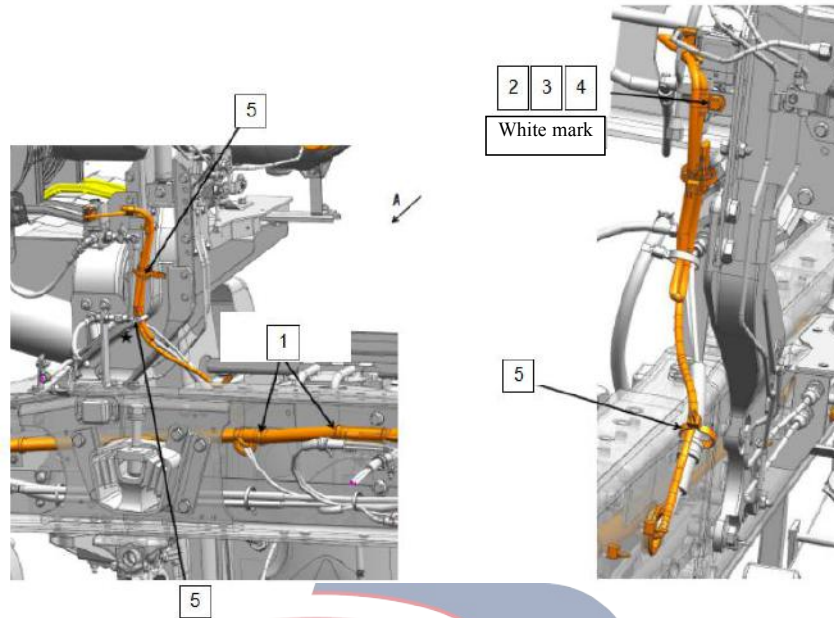

Assembly requirements:

1. Fix the harness-front frame (1) onto the position as shown on the right with parts (2)(3)(4)(5).

Assembly details:

1. Wiring harness-front frame segment
2. Clip
3. Bolt (Q1840820)
4. Nut (Q32008)
5. Binding tape

POWERSTAR

Urea tank harness fixing

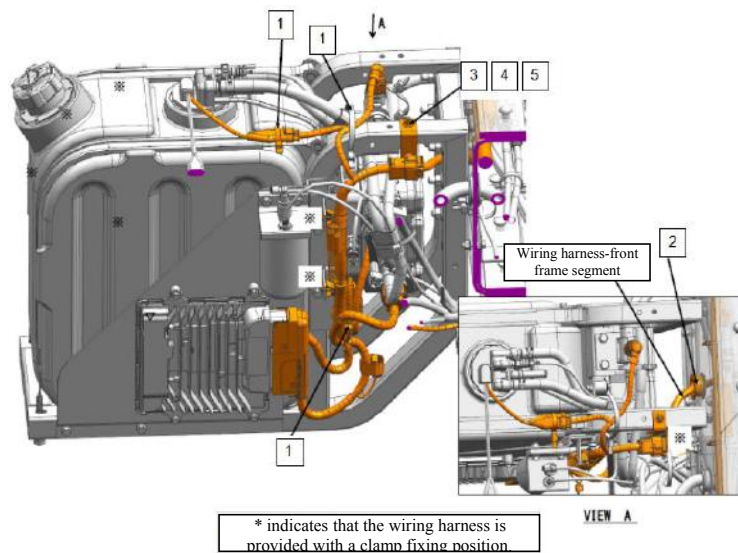

Assembly requirements:

1. Fix the starter harness and front frame harness with parts (1)(2)(3)(4) and (5) as shown on the right.

Assembly details:

1. Binding tape
2. Jacket
3. Support (3724721-D17YZ)
4. Bolt (Q1840820)
5. Nut (Q32008)



POWERSTAR

Starter harness fixing (6W)

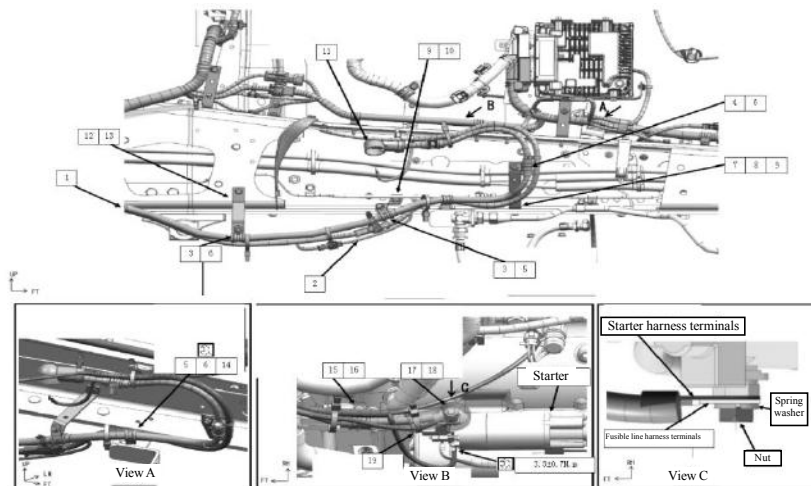

Assembly requirements:

1. Assemble parts (1) to (19) as shown in the figure.

Assembly details:

- | | |
|-----------------------------|------------------------------------|
| 1. Wiring harness-starter | 11. Insulation phase (3703113-117) |
| 2. Fusible wire | 12. Support (3703136-D17YZ) |
| 3. Clip (1002214-850) | 13. Bolt (Q1840825) |
| 4. Clip | 14. Clip (3703245-117/C) |
| 5. Bolt (Q1840820) | 15. Clip (1002214-850) |
| 6. Nut (Q32008) | 16. Bolt (Q1840820) |
| 7. Support (3703138-D17YZ) | 17. Nut |
| 8. Bolt (Q1840830) | 18. Spring washer (Q40510) |
| 9. Nut (Q32008) | 19. Binding tape |
| 10. Support (3703135-D17YZ) | |

Front left harness fixing (6W)

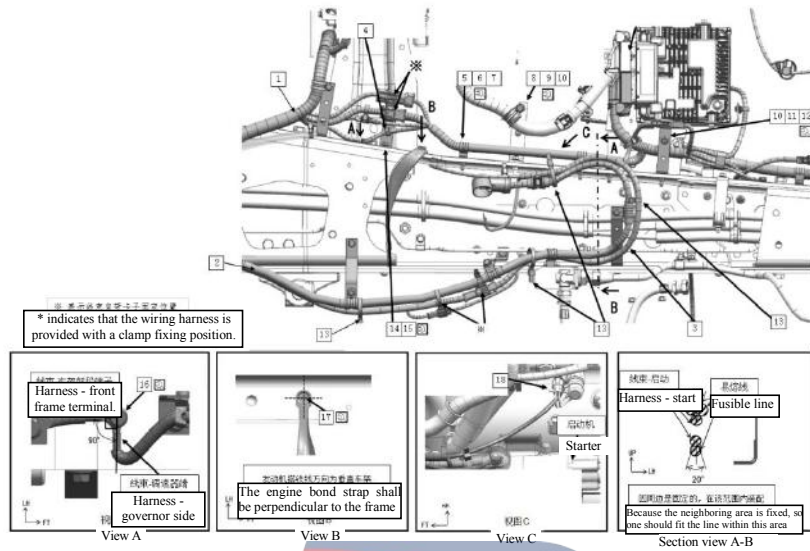

Assembly requirements:

1. Assemble parts (1) to (18) as shown in the figure.

Assembly details:

- | | |
|---------------------------------------|-----------------------------------|
| 1. Wiring harness-front frame segment | 10. Nut (Q32008) |
| 2. Wiring harness-starter | 11. Support (3724327-D17YZ) |
| 3. Fusible wire | 12. Bolt (Q1840820) |
| 4. Clip | 13. Binding tape |
| 5. Clip | 14. Support (3724327-D17YZ) |
| 6. Bolt (Q1840830) | 15. Bolt (Q1840835) |
| 7. Nut (Q32008) | 16. Bolt (Q1840835) |
| 8. Clip (3724566-803) | 17. Nut (Q1841216) |
| 9. Bolt (Q1840820) | 18. Spring washer (3703237-117/C) |

Muffler harness fixing

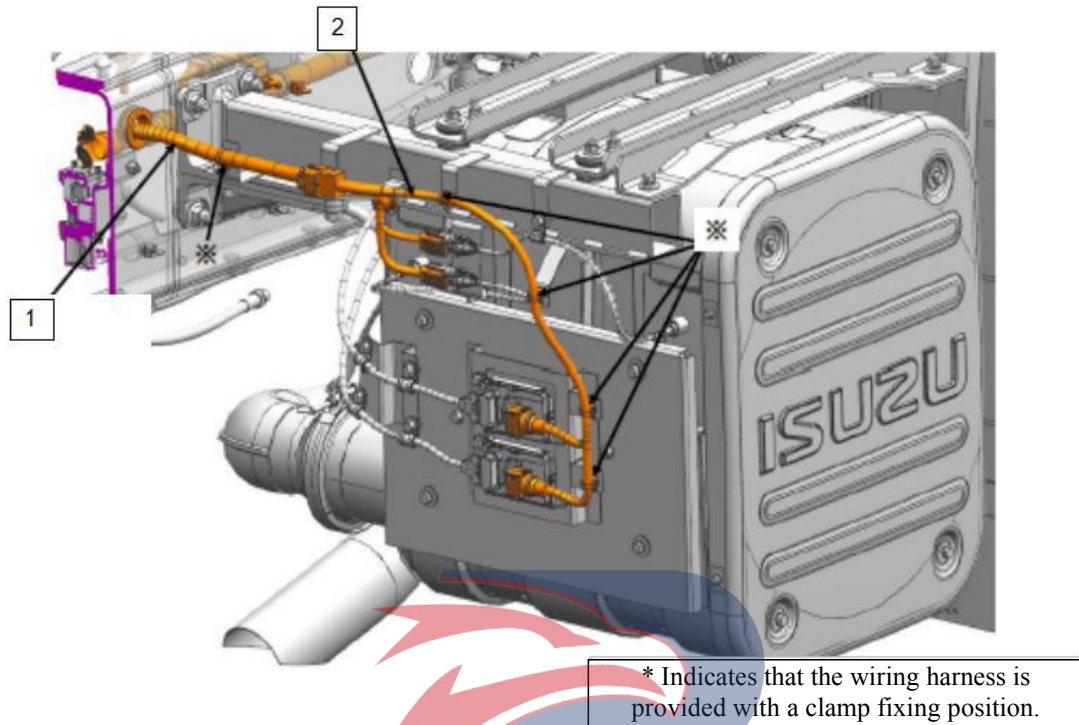

Assembly requirements:

1. Fix the harness-silencer (2) as shown on the right and connect it to harness-front frame (1) plug.

Assembly details:

1. Wiring harness-front frame segment
2. Wiring harness-silencer (EXR/EXZ) (3724590-D17YZ)
3. Wiring harness-silencer (3724590-D15EH)

POWERSTAR

Battery harness fixing

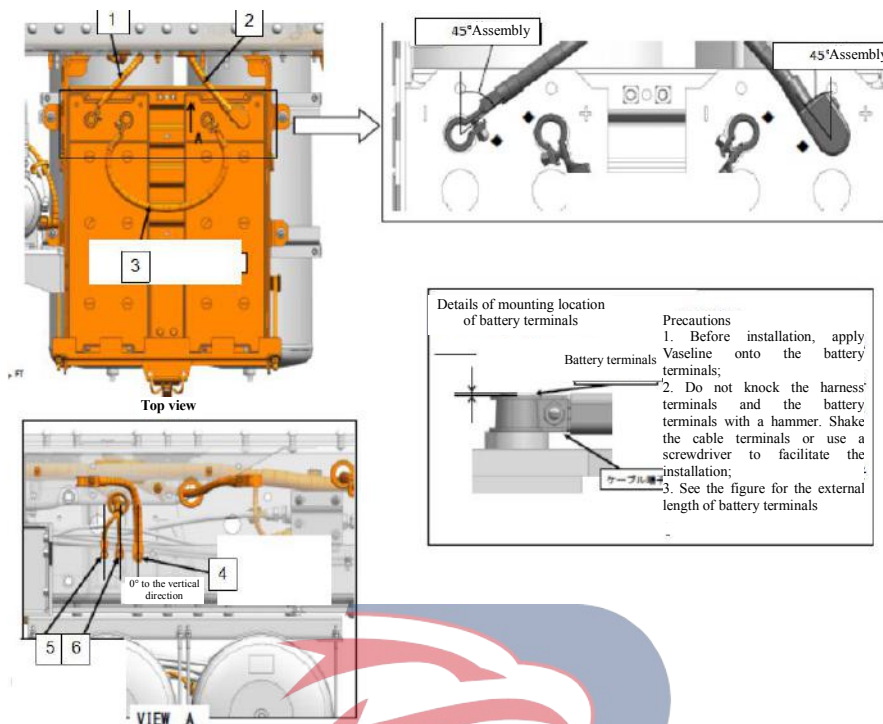

Assembly requirements:

1. Assemble parts (1)(2)(3)(4)(5) and (6) as shown in the figure.

Assembly details:

1. Harness-battery cathode
2. Harness-starter
3. Harness-battery anode to cathode
4. Ground bolt (
5. Gasket (3703224-117/C)
6. Ground bolt

POWERSTAR

1st-beam harness fixing

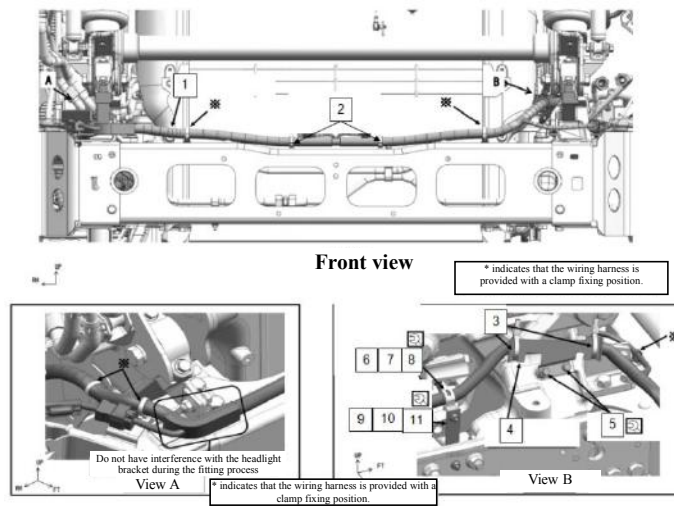

Assembly requirements:

1. Fix the harness-governor (1) onto the position of the 1st beam as shown on the right with parts (3)(4)(5)(6)(7)(8)(9)(10) and (11).

Assembly details:

1. Harness-governor
2. Binding tape
3. Binding tape
4. Support
5. Bolt (Q1840820)
6. Clip (3509065-P301)
7. Bolt (Q1840820)
8. Nut (Q32008)
9. Support (3724328-D17YZ)
10. Bolt (Q1840830)
11. Nut (Q32008)

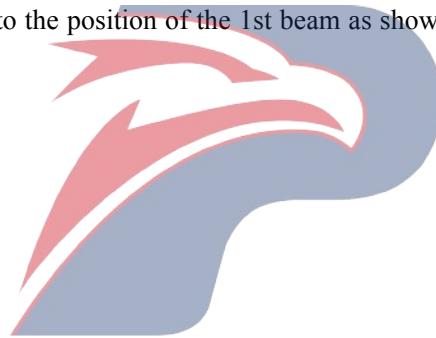

POWERSTAR

Silencer and engine connection

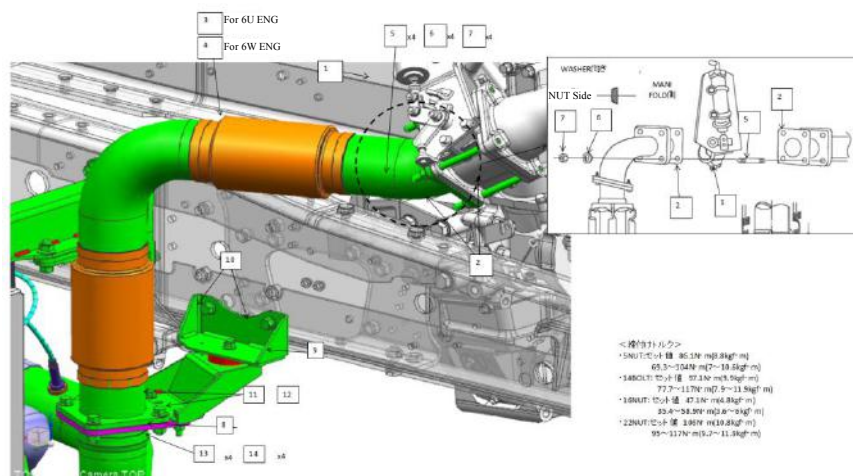

Assembly requirements:

1. Assemble parts (1)(2)(3)(4)(5)(6)(7)(8)(9)(10)(11)(12)(13) and (14) as shown in the figure.

Assembly details:

1. Exhaust brake valve assembly (8976297373)
2. Gasket-exhaust manifold (1203426-D17YZ)
3. Exhaust pipe assembly (for 6U ENG) (1203010-D15YR)
4. Exhaust pipe assembly (for 6U ENG) (1203010-D15YR)
5. Bolt
6. Washer
7. Nut
8. Gasket-exhaust manifold (1203426-D17YZ)
9. Support assembly (1203185-D17YZ)
10. Bolt (Q1841235(P=1.25))
11. Bolt (Q1841035(P=1.25))
12. Nut (Q32010T13F2(P=1.25))
13. Bolt (Q1841235(P=1.25))
14. Nut (Q32012T13F2(P=1.25))

POWERSTAR

Exhaust pipe protection support sub-assembly

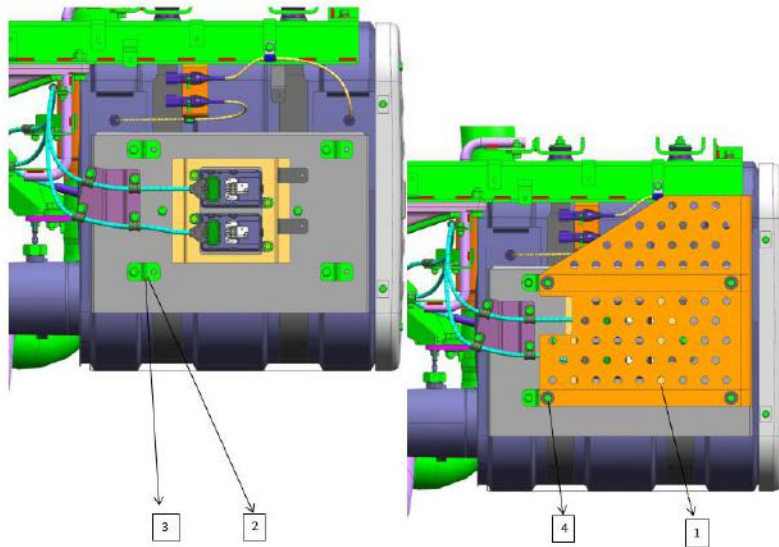

Assembly requirements:

1. Assemble parts (1)(2) and (3) as shown in the figure.

Assembly details:

1. Support (1205179-D17YZ)
2. Support (1205161-D17YZ)
3. Bolt (Q1840825)
4. Bolt (1205069-D17YZ)

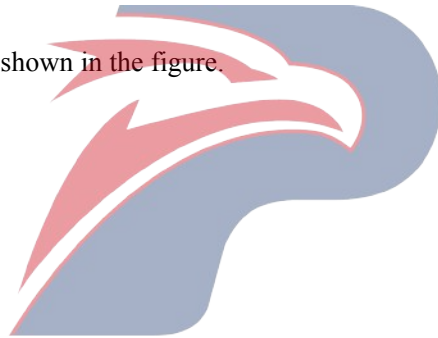

POWERSTAR

Muffler assembly hoisting

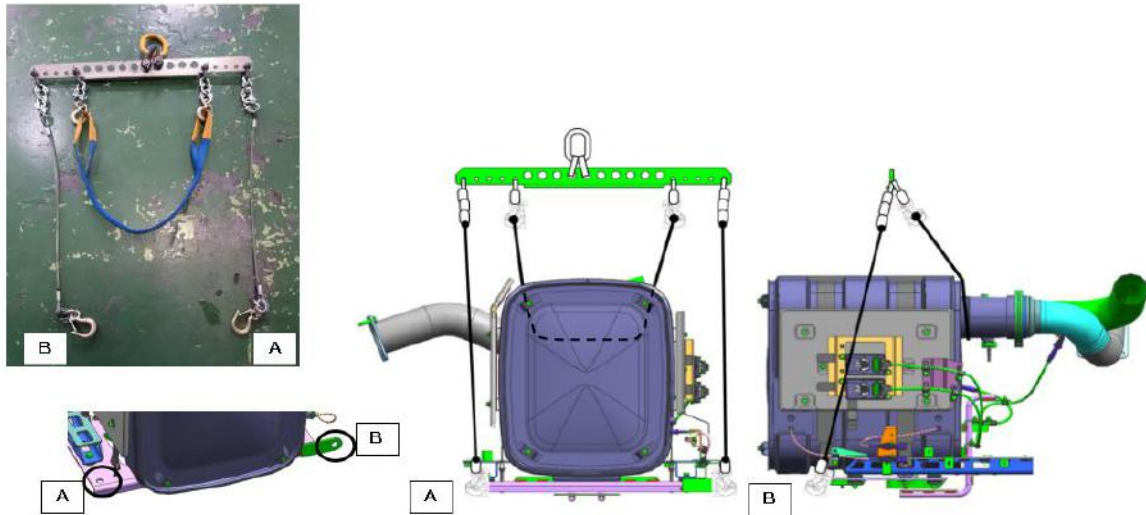

Assembly requirements:

1. As shown, before turning over the frame, the muffler assembly is lifted to the frame with a lifting sling (paying attention to the lifting points).

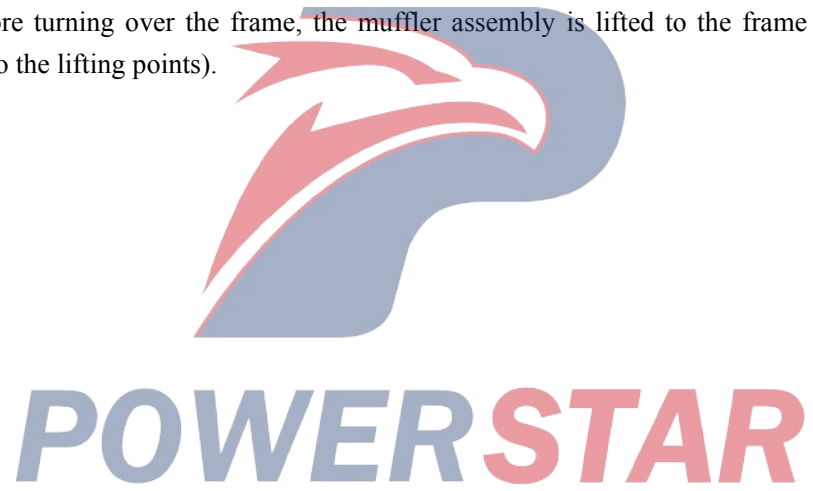

Battery electrode connection

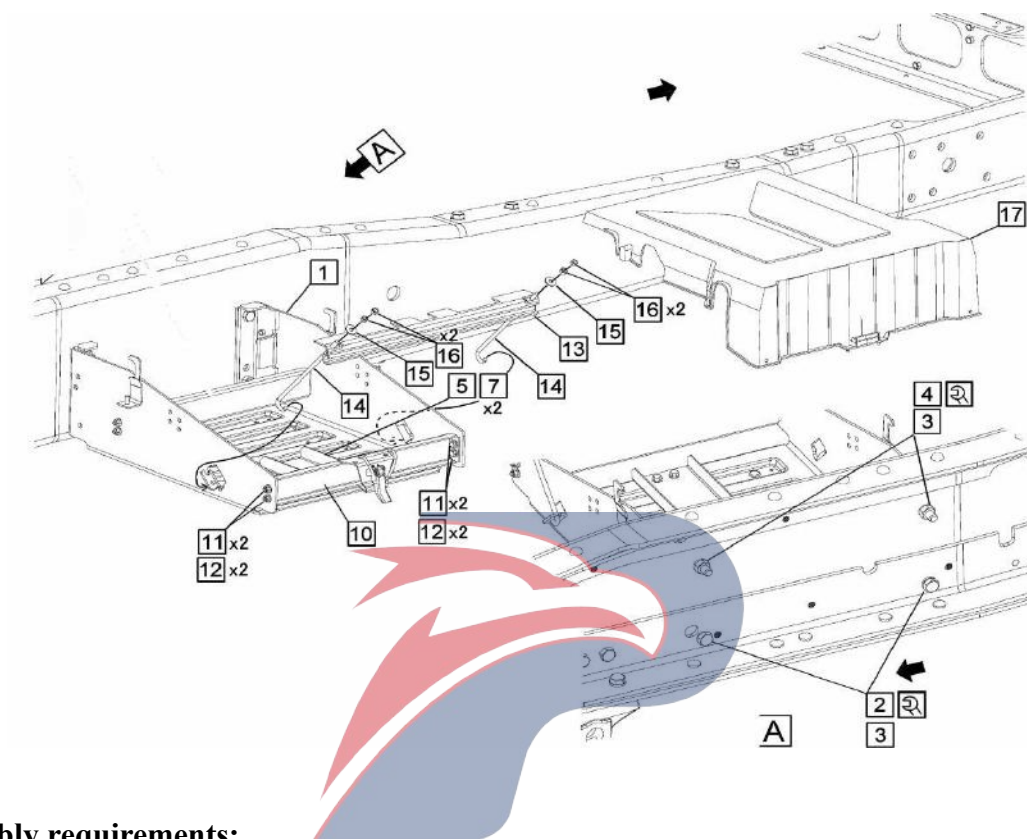

Assembly requirements:

1. Fix support 1 onto the frame with bolt 2, spring washer 3 and nut 4. Torque of bolt and nut: 93~138N.m.
2. Fix gasket 5 onto the support 1 with bolt 7.
3. Fix front plate 10 onto the support 1 with bolt 11 and nut 12.
4. When the battery electrodes are connected, fix the battery with parts 13, 14, 15 and 16.
5. Cover the battery with battery cover plate 17 and fasten part 17 with part 10.

Assembly details:

1. Support assembly-battery (3703130-D34EZ)
Support assembly-battery (EXZ/EXR) (3703130-D17YZ)
2. Bolt
3. Spring washer (Q40314)
4. Nut
5. Gasket (
7. Bolt (Q1840816)
10. Front plate
11. Bolt (Q1840820)
12. Nut (Q32008)

- 13. Front support
- 14. Bolt
- 15. Washer (Q40208)
- 16. Nut (Q340B08)
- 17. Battery cover plate (3703151-D17YZ)

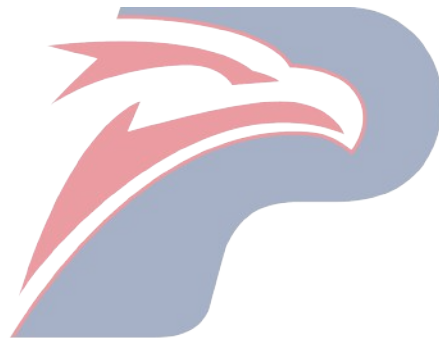

POWERSTAR

Oil pipe connection

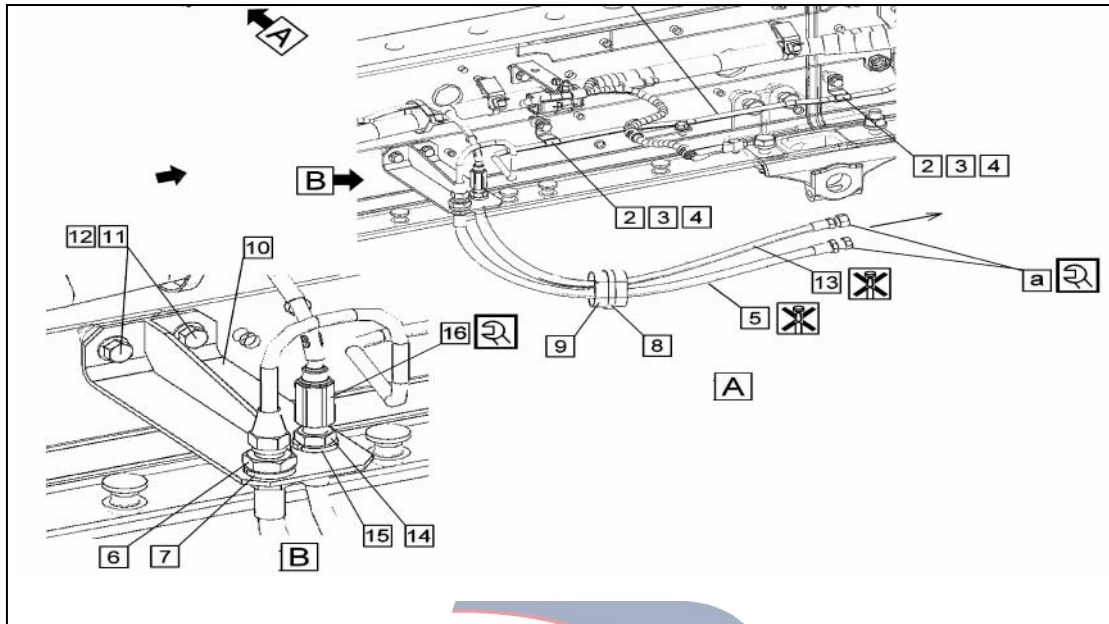

Assembly requirements:

1. Fix the oil pipe 1 with parts 2, 3 and 4, and fix the support 10 onto the frame with parts 11 and 12.
2. Connect parts 1 and 5 with parts 6 and 7, and also connect parts 13 and 16 with parts 14 and 15.
3. Connect parts 5 and 13 with parts 8 and 9.
4. Torque of part 16: $13.25 \pm 1.45 \text{ N.m}$.
5. The other end of part 13.5 is connected to the transmission at a torque of 28.4 N.m .

Assembly details:

1. Oil pipe
1. Oil pipe (1602055-D17YZ)
2. Pipe clamp
3. Bolt (Q1840830)
4. Nut (Q32008)
5. Rubber hose (1607056-D15YR)
5. Rubber hose (1607058-D17YZ)
6. Nut (Q351B14T15)
7. Spring washer (Q40314)
8. Clip
9. Rubber sleeve
10. Support
10. Support (1607059-D15EH)
11. Bolt (Q1840835)
12. Nut (Q32008)
13. Rubber hose (1607061-D15YR)

POWERSTAR

13. Rubber hose(1607062-D17YZ)

14. Nut (Q351C12)

15. Spring washer (Q40312)

16. connector (1703046-117)

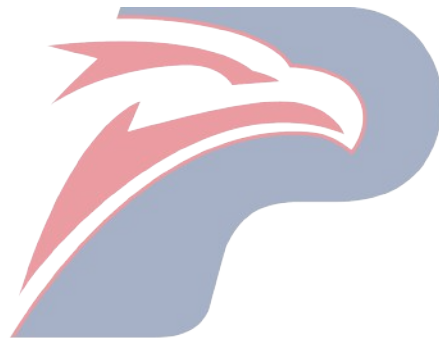

POWERSTAR

Oil pipe connection

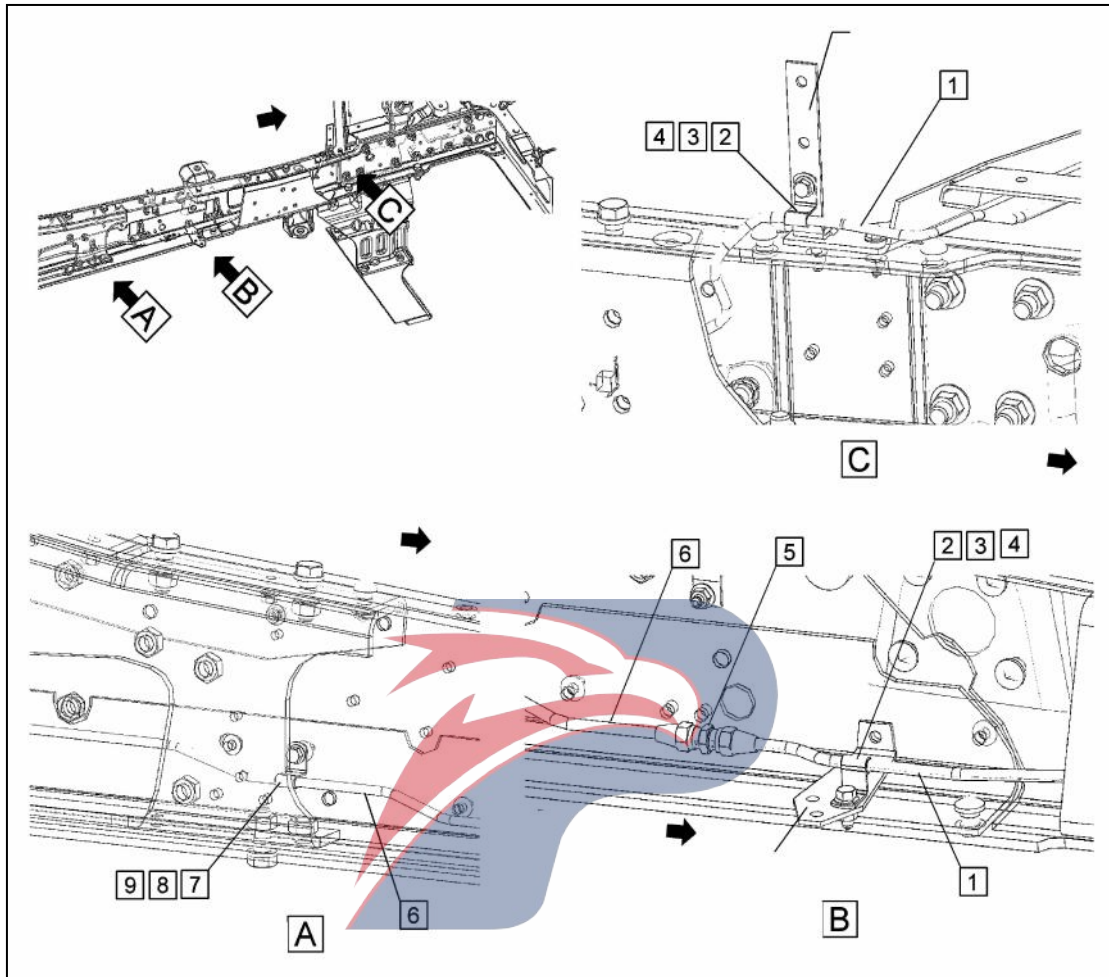

Assembly requirements:

1. Fix the oil pipe ① with parts ②, ③ and ④, and connect oil pipes ① and ⑥ with part ⑤.
2. Fix oil pipe ⑥ with parts ⑦, ⑧ and ⑨ as shown in the figure.

Assembly details:

1. Oil pipe (1602020-D34EZ)
1. Oil pipe (1602020-D17YZ)
2. Pipe clamp
3. Bolt (Q1840820)
4. Nut (Q32008)
5. Connector
6. Oil pipe
6. Oil pipe (1602055-D17YZ)
7. Pipe clamp
8. Bolt (Q1840830)
9. Nut (Q32008)

Oil tank hose assembly

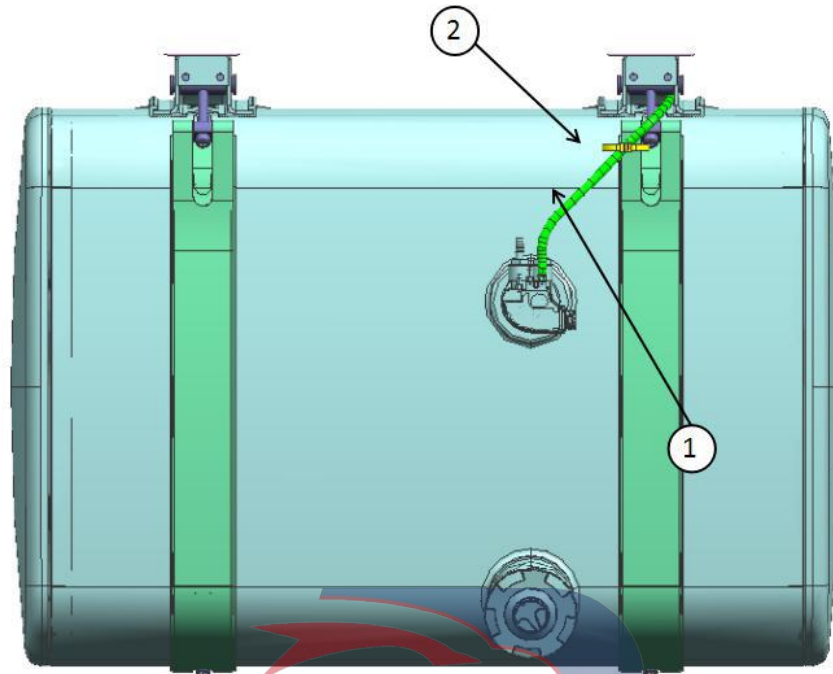

Assembly requirements:

1. Secure hose ① on the fuel sensor.
2. As shown on the right, tie the hose with a binding tape.

Assembly details:

1. Hose
2. Binding tape

POWERSTAR

Oil tank bracket assembly

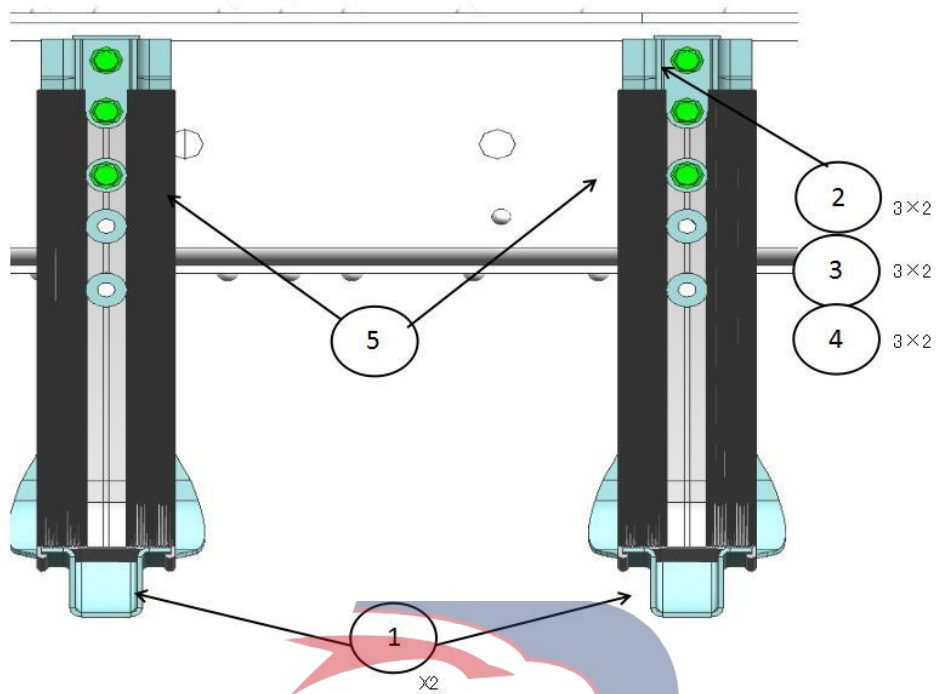

Assembly requirements:

1. Place the oil tank bracket 1 on the corresponding hole on the frame, and use bolt 2 to pass through gasket 3, bracket, frame and the nut 4.
2. Mount the bracket pad 5 on the tank bracket 1.
3. Tighten the bolt (2) at a torque of 390 (350 ~ 430) N.m.

Assembly details:

1. Bracket assembly
2. Bolt (Q151B1650TF2)
3. Washer (Q40116)
4. Nut (Q32016T13(P=1.5))
5. Bracket pad

Oil tank assembly

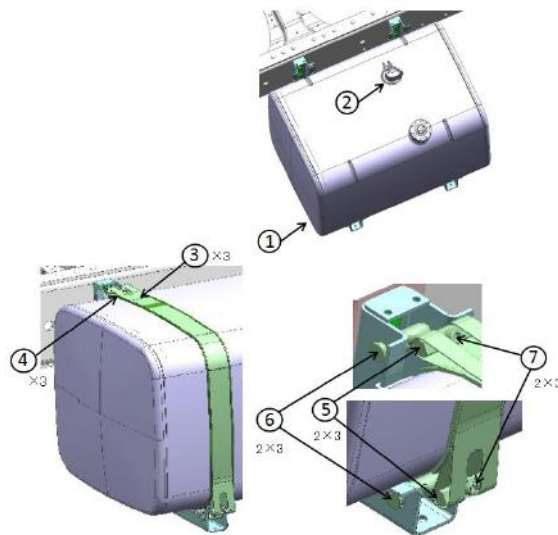

Assembly requirements:

1. Sub-assemble the fuel sensor 2 on the oil tank assembly 1.
2. Put the oil tank on the oil tank bracket.
3. Assemble the pad belt 4 at the corresponding location as shown in the figure.
4. Put threaded pin 6 through the end of oil tank bracket, put the adjusting pin 5 through the pull belt 3, tighten the pull belt with inner hexagon screw 7, confirm the torque 35 ~ 50N.m and mark it red

Assembly details:

1. Oil tank assembly (400L)
2. Fuel sensor
3. Pull belt
4. Pull belt and pad belt
5. Adjusting pin
6. Threaded pin
7. Inner hexagon screw

POWERSTAR

Right cover assembly

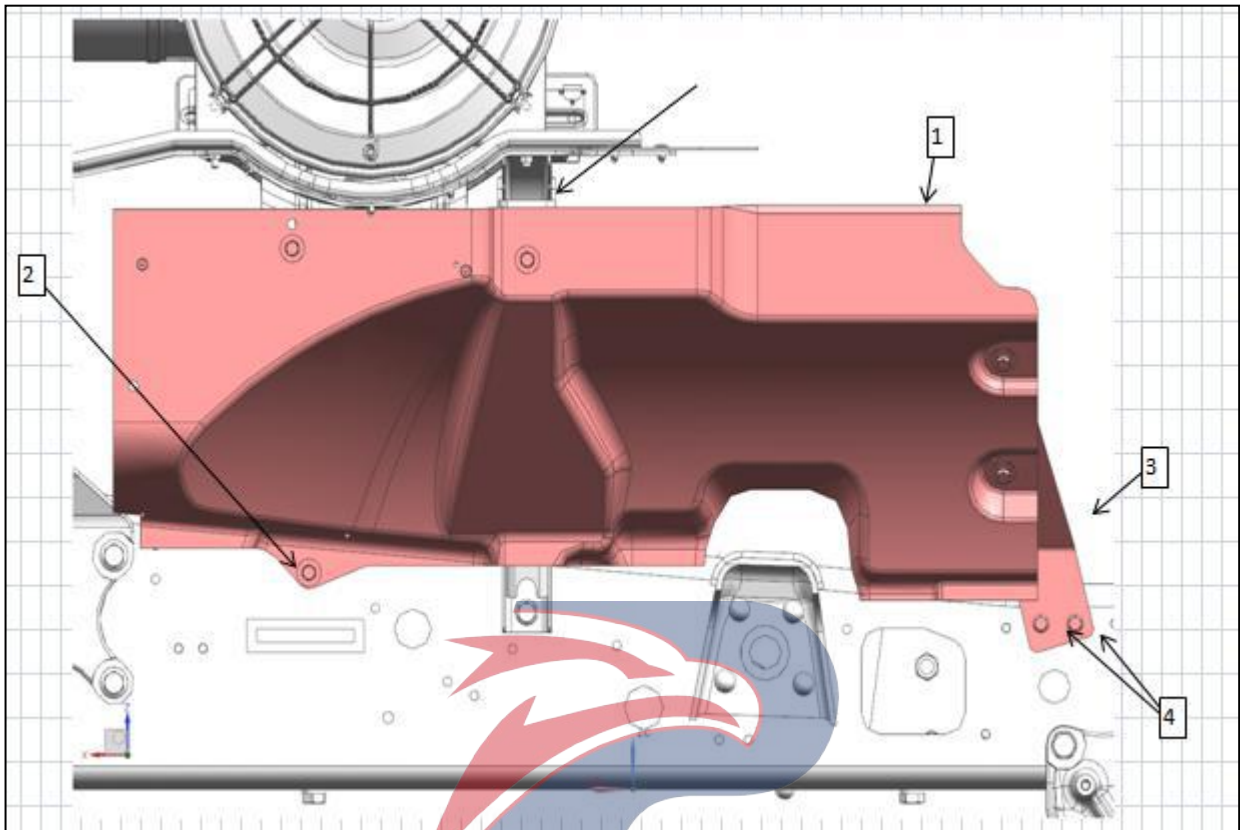

Assembly requirements:

1. Fix the support 3 into the corresponding hole of the frame with the bolt (4).
2. Fix the cover assembly 1 into the corresponding hole with the bolt 2.

Assembly details:

1. Cover assembly 3102210-D17YZ
2. Bolt 5002117-P301
3. Support
4. Bolt Q1840830

Right hood support

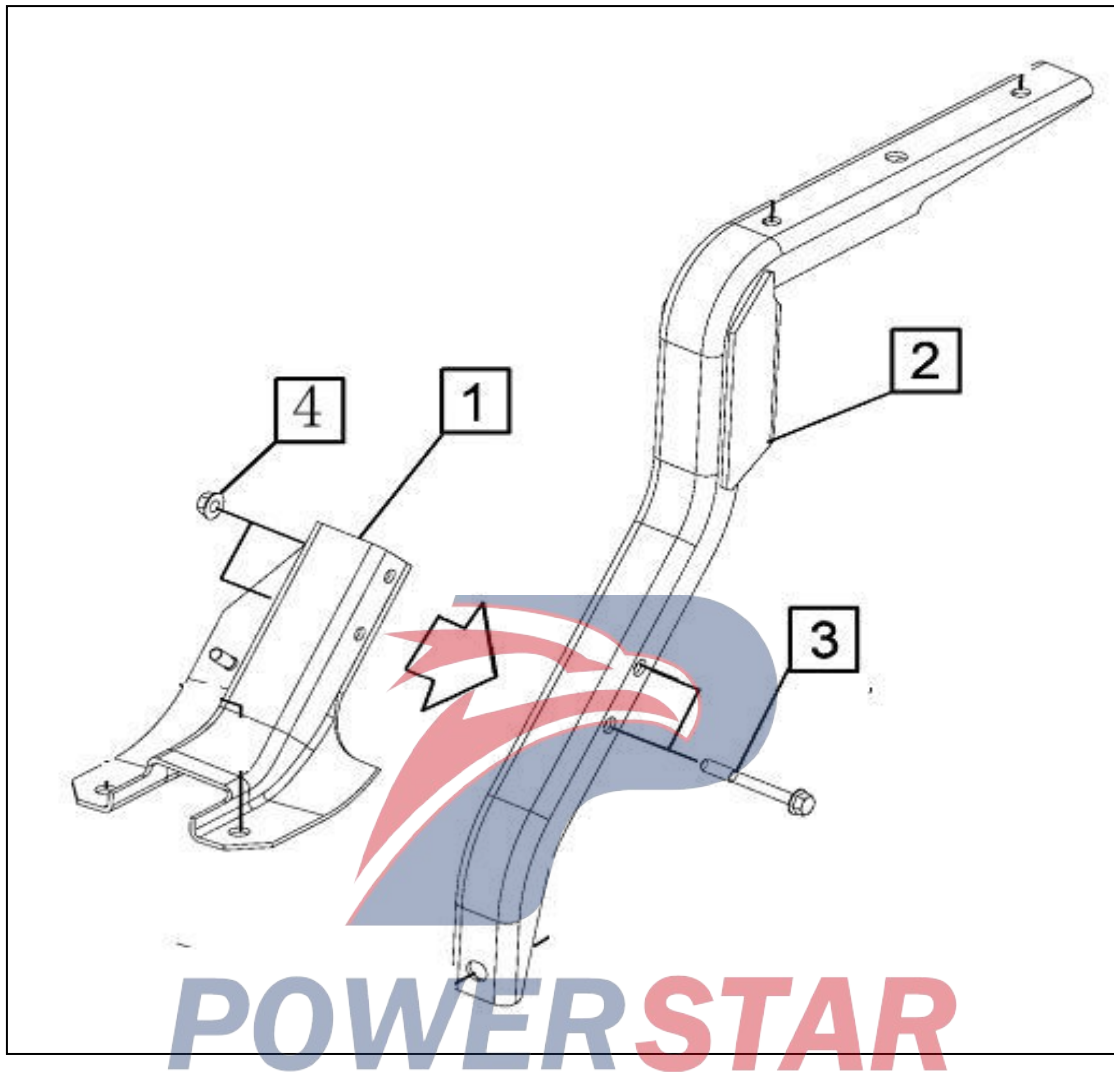

Assembly requirements:

1. As shown in the figure, place the support (1) on the support (2), take the bolt (3) sequentially through the support (1) \ support (2), screw the nut (4) with 2 ~ 3 pitches, not fastened.

Assembly details:

1. Bracket -air filter (1109311-D17YZ)
2. Bracket -air filter (1109312-D17YZ)
3. Bolt Q1840870
4. Nut Q32008

Affix the identification plate

Attached drawing.

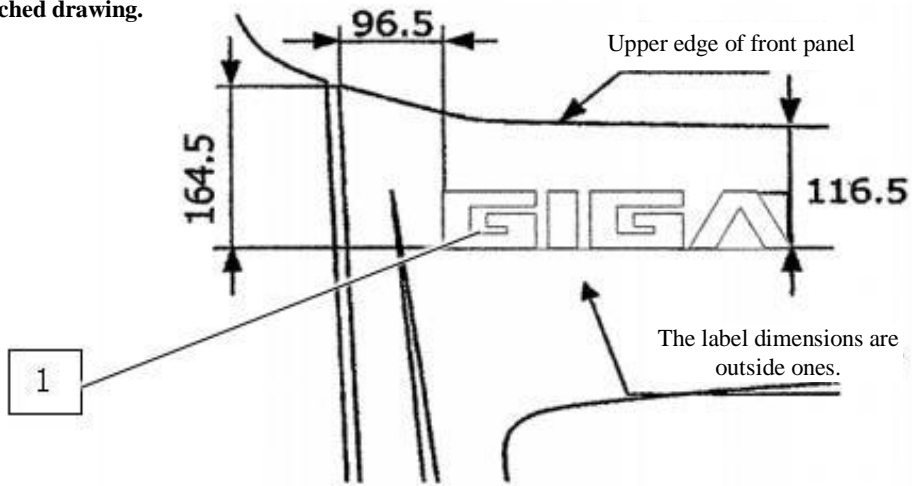

Paste position for the right front "GIGA" ID plate (the same as Isuzu)

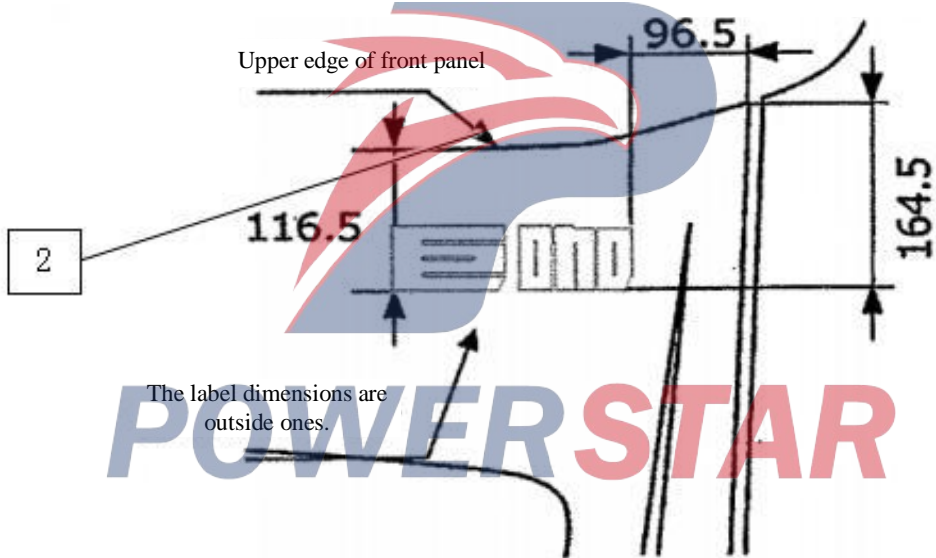

Left front "GIGA" ID plate

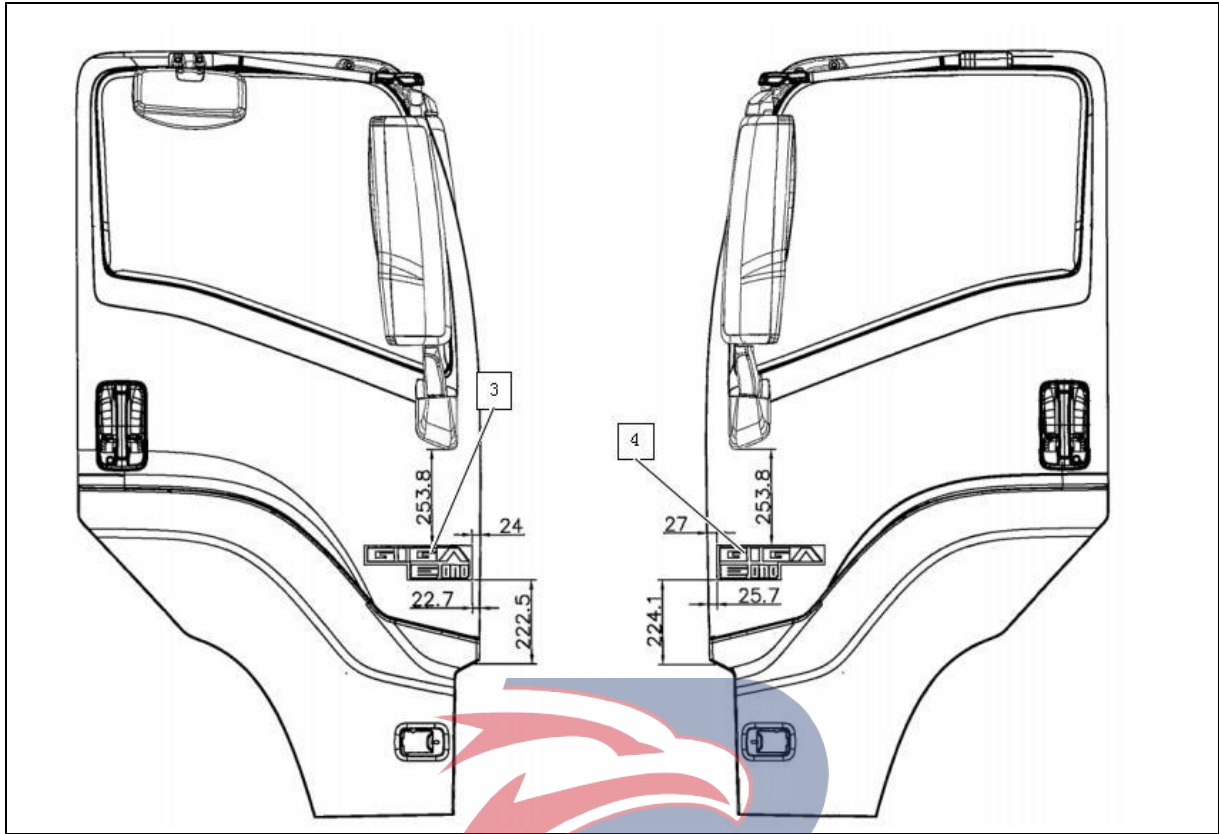

Assembly requirements:

Clean the paste area with a towel, and affix the identification plate as shown in the figure; the paste area must be dust-free;

Assembly details:

1. Identification plate-right front (3903311-D17YZ)
2. Identification plate-left front (3903312-D17YZ)
3. Identification plate-left door (3903313-D17YZ)
4. Identification plate-right door (3903314-D17YZ)

POWERSTAR

Fit the bracket

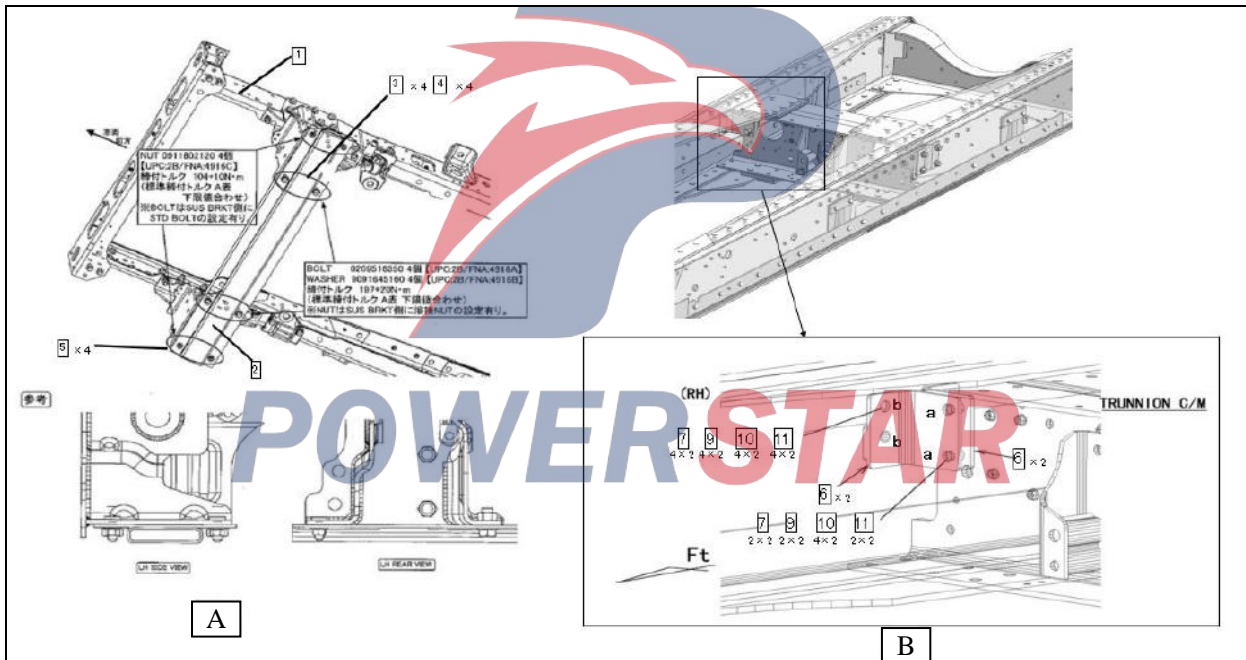
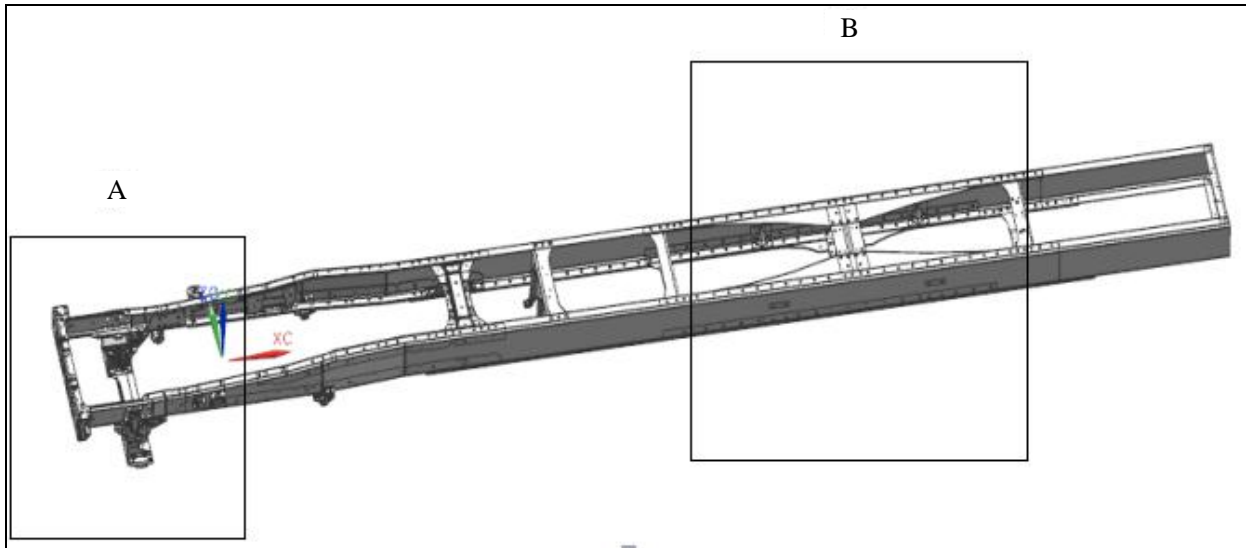

Assembly requirements:

1. Connect and tighten the frame assembly ①, reinforced beam-front bracket of support leaf spring ② as well as bracket - beam ⑥ with bolts, nuts, washers and spring washers ③, ④, ⑤, ⑦, ⑧, ⑨, ⑩ and ⑪.

Assembly details:

- 1. Frame assembly (2800010-D15YR)
- 1. Frame assembly (2800010-D17YZ)
- 1. Frame assembly (2800010-D15YZ)
- 1. Frame assembly (2800010-D34EZ)
- 1. Frame assembly (2800010-D25EZ)
- 1. Frame assembly (2800010-D26EZ)

1. Frame assembly (2800010-D15EH)
1. Frame assembly (2800010-D16EH)
1. Frame assembly (2800010-D27JH)
1. Frame assembly (2800010-D25EH)
2. Reinforced beam-front bracket of support leaf spring
3. Bolt (Q151B1635T)
4. Washer (Q40116)
5. Nut (Q32012T13F2)
6. Support-beam connection
7. Bolt (Q151B1440TF2)
8. Bolt (Q151B1455T)
9. Spring washer (Q40514)
10. Washer (Q40014)
11. Nut (Q341B14)

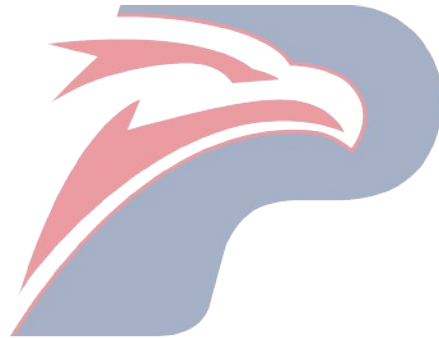

POWERSTAR

Drive shaft installation

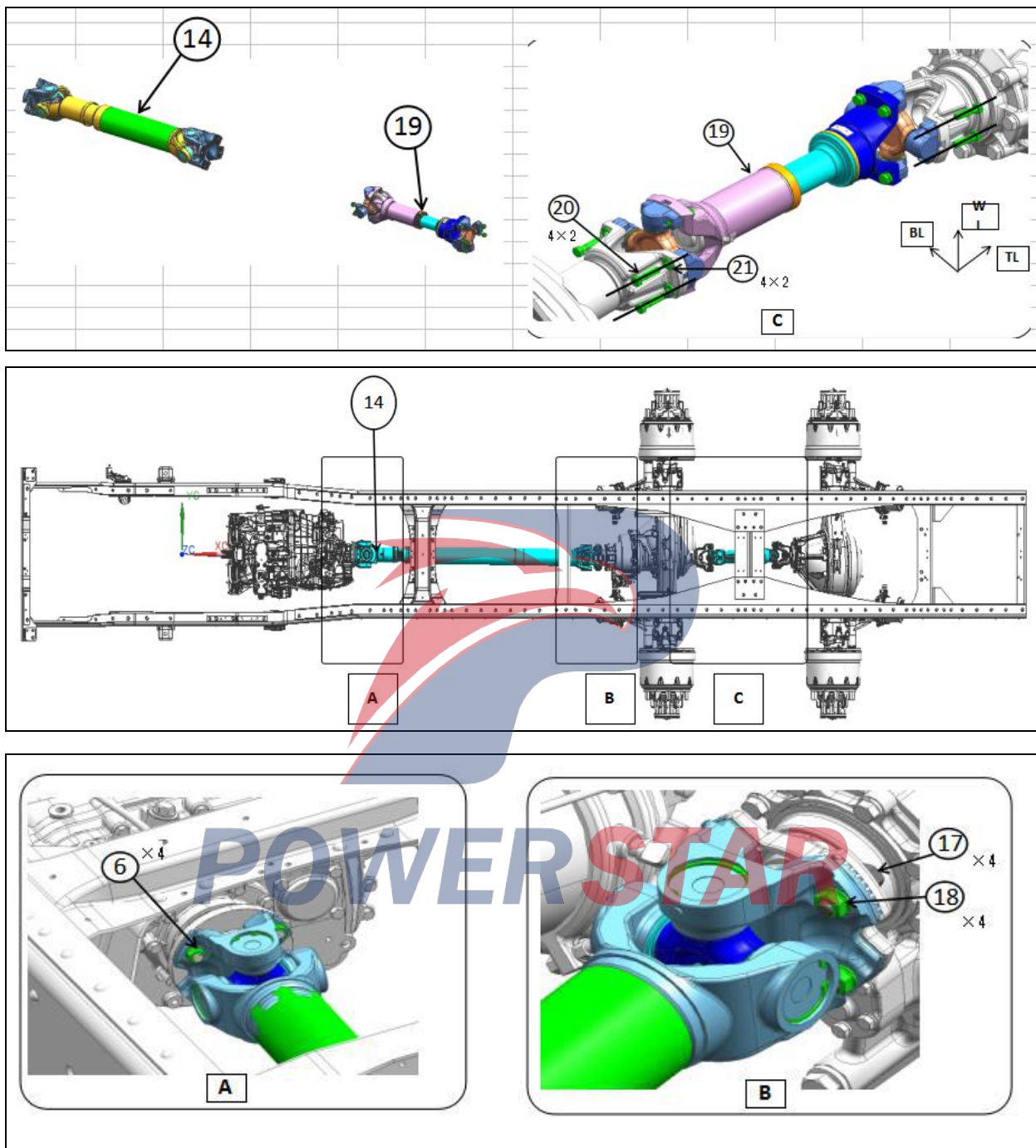

Assembly requirements:

1. Connect and tighten the drive shaft assemblies 14 and 19 with bolts 17 and 20, nuts 6 and 18, and spring washer 21 as shown in the figure.

Assembly details:

6. Nut

14. Drive shaft assembly (2201030-D34EZ)

14. Drive shaft assembly(2201030-D35EZ)

- 17. Bolt
- 18. Nut
- 19. Drive shaft assembly (2201040-D17YZ)
- 20. Bolt
- 21. Spring washer (Q40512)

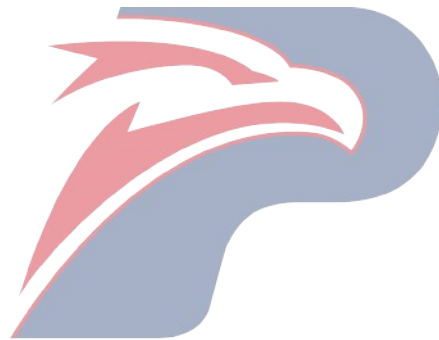

POWERSTAR

Drive shaft installation

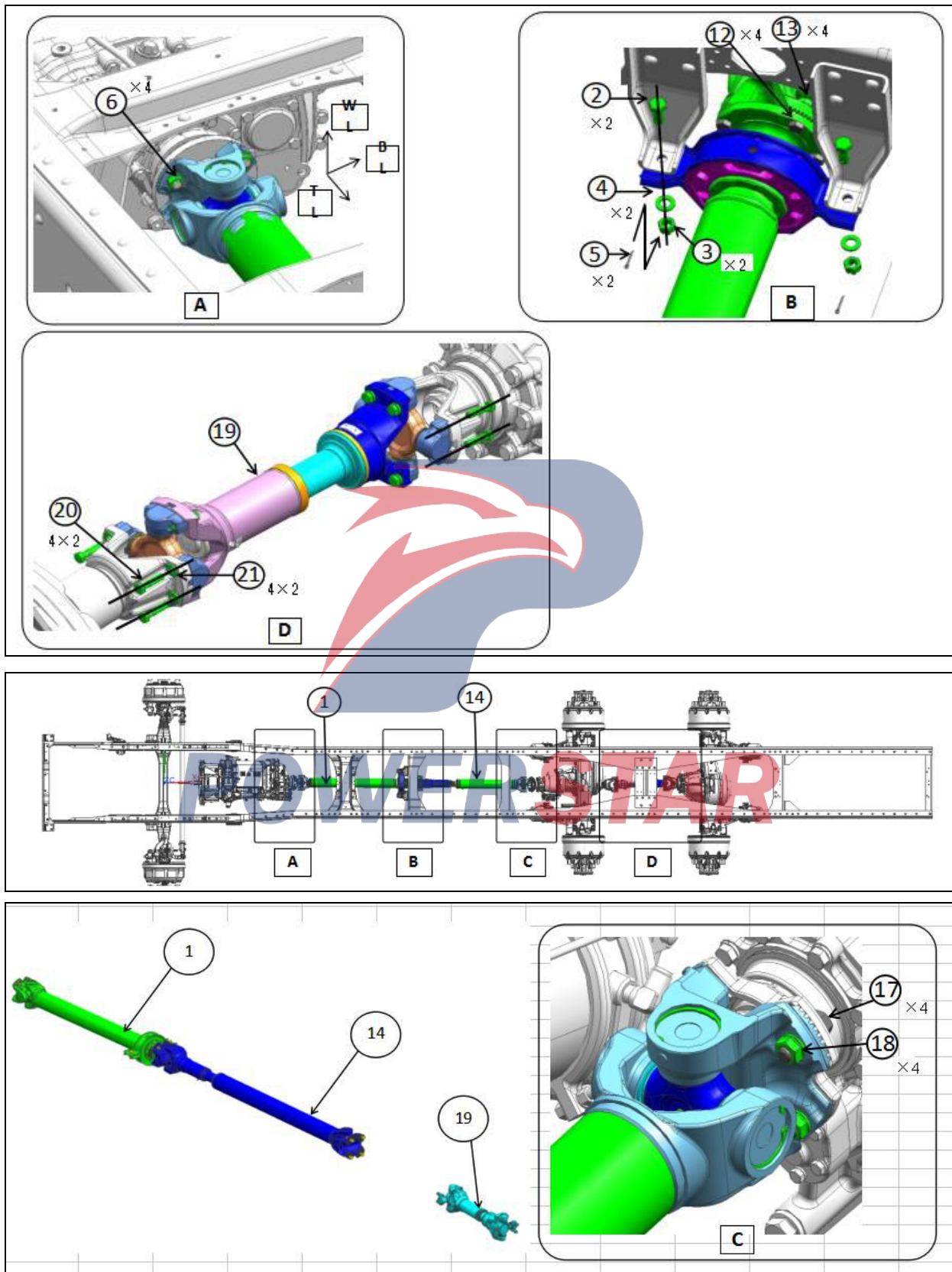

Assembly requirements:

1. Connect and tighten the drive shaft assemblies 1, 14 and 19 with bolts 2, 12, 17 and 20, nuts 3, 6, 13 and 18, and split pin 5 and spring washer 21 as shown in the figure.

Assembly details:

1. Drive shaft assembly (2201010-D26EH)
1. Drive shaft assembly (2201010-D25EZ)
2. Bolt
3. Nut
4. Washer (Q40116)
5. Split pin (Q5004040)
6. Nut
12. Bolt
13. Nut
14. Drive shaft assembly (2201030-D25EZ)
17. Bolt
18. Nut
19. Drive shaft assembly (2201040-D17YZ)
20. Bolt
21. Spring washer (Q40512)

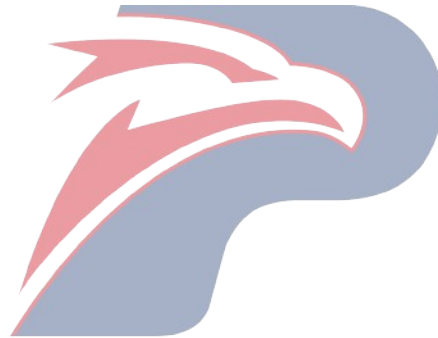

POWERSTAR

Drive shaft installation

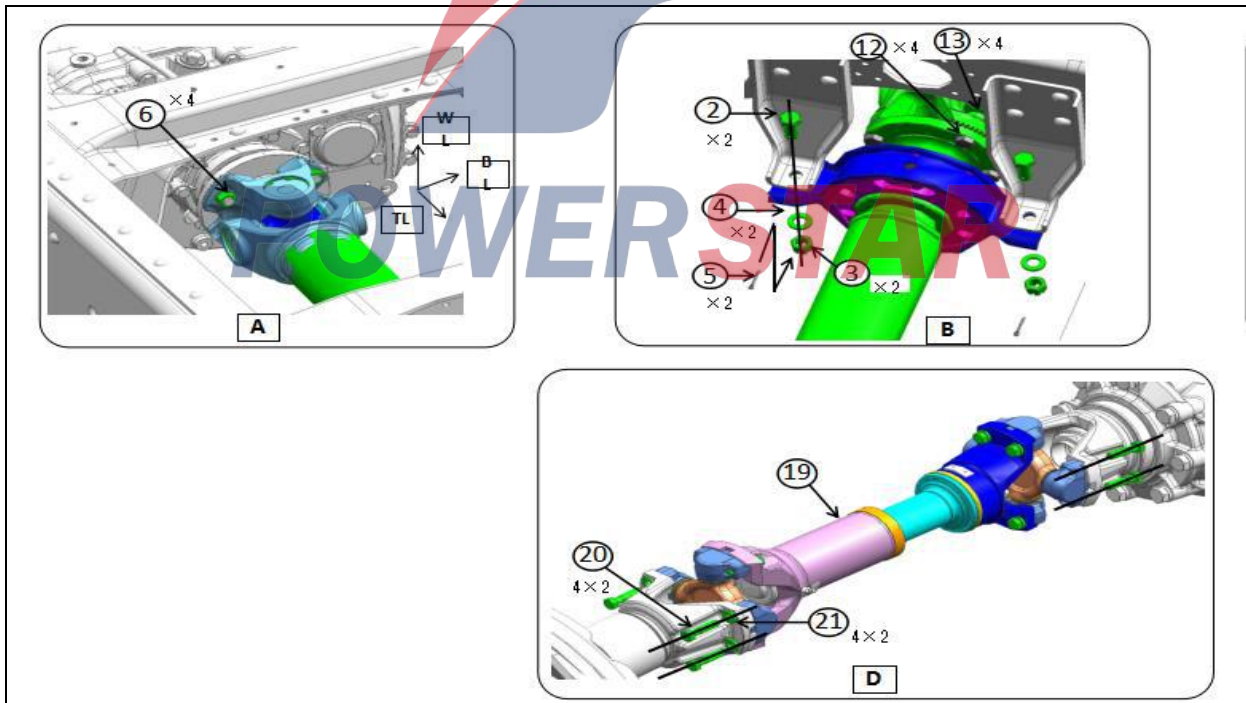
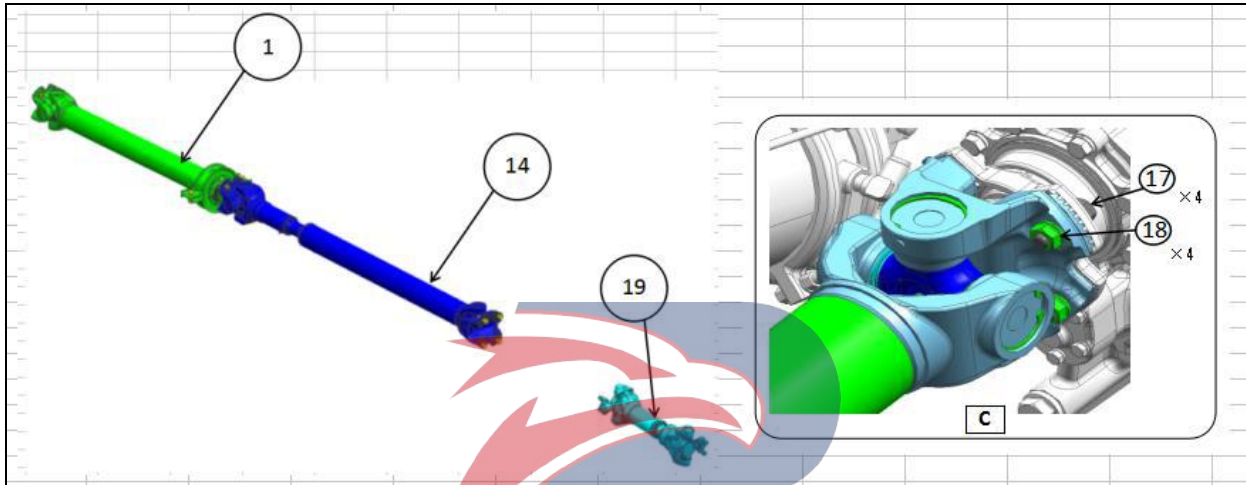
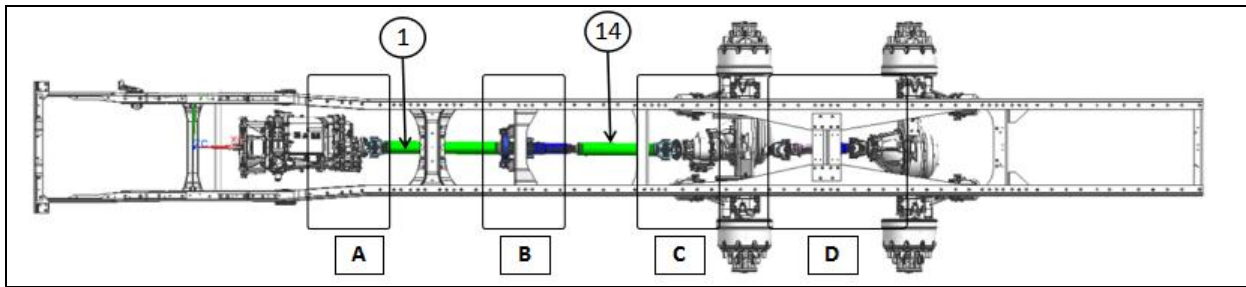

Assembly requirements:

1. Connect and tighten the drive shaft assemblies 1, 14 and 19 with bolts 2, 12, 17 and 20, nuts 3, 6, 13 and 18, and split pin 5 and spring washer 21 as shown in the figure.

Assembly details:

1. Drive shaft assembly (2201010-D16EH)
1. Drive shaft assembly (2201010-D14EH)

1. Drive shaft assembly (2201010-D25EZ)
2. Bolt
3. Nut
4. Washer (Q40116)
5. Split pin (Q5004040)
6. Nut
12. Bolt (
13. Nut
14. Drive shaft assembly (2201030-D14EH)
17. Bolt
18. Nut
19. Drive shaft assembly (2201040-D17YZ)
20. Bolt
21. Spring washer (Q40512)

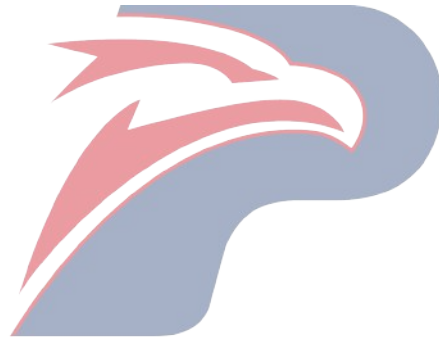

POWERSTAR

Drive shaft installation

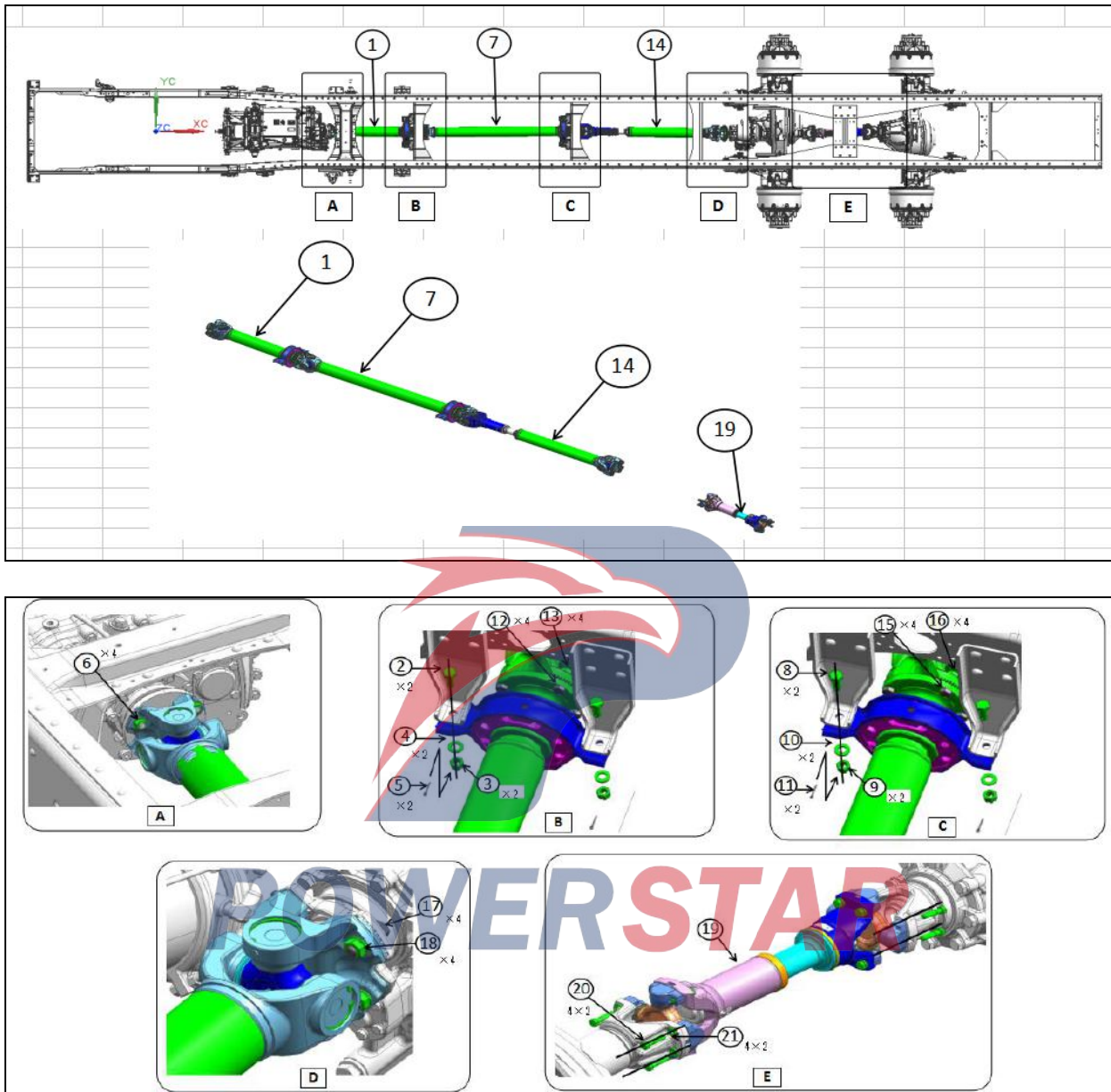

Assembly requirements:

1. Connect and tighten the drive shaft assemblies 1, 7, 14 and 19 with bolts and nuts 2, 3, 6, 8, 9, 12, 13, 15, 16, 17, 18 and 20, and spring washers 4, 10, 21 and split pins 5 and 11 as shown in the figure.

Assembly details:

1. Drive shaft assembly (2201010-D26EH)
1. Drive shaft assembly (2201010-D25EZ)
2. Bolt
3. Nut
4. Washer (Q40116)
5. Split pin (Q5004040)

6. Nut
7. Drive shaft assembly(2201020-CEH24)
8. Bolt
9. Nut
10. Washer (Q40116)
11. Split pin (Q5004040)
12. Bolt (
13. Nut
14. Drive shaft assembly(2201030-D25EH)
15. Bolt
16. Nut
17. Bolt
18. Nut
19. Drive shaft assembly (2201040-D17YZ)
20. Bolt
21. Washer (Q40512)

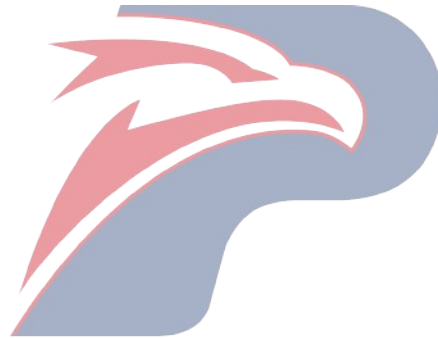

POWERSTAR

Drive shaft installation

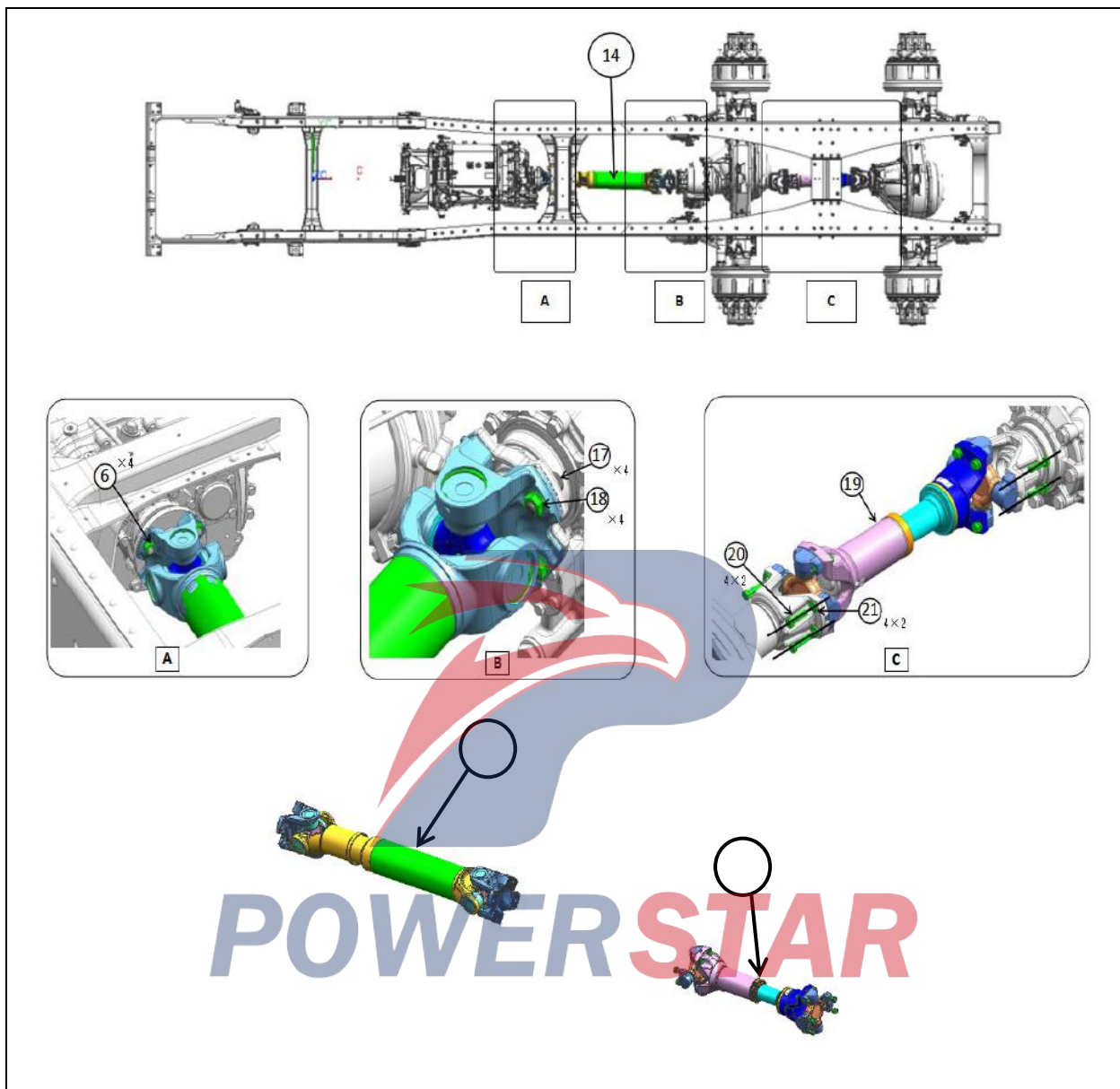

Assembly requirements:

1. Connect and tighten the drive shaft assemblies 14 and 19 with bolts 17 and 20, nuts 6 and 18, and spring washer 21 as shown in the figure.

Assembly details:

- 6. Nut
- 14. Drive shaft assembly (2201030-D17YZ)
- 14. Drive shaft assembly(2201030-D15YZ)
- 17. Bolt
- 18. Nut
- 19. Drive shaft assembly (2201040-D17YZ)
- 20. Bolt
- 21. Spring washer (Q40512)

Drive shaft installation

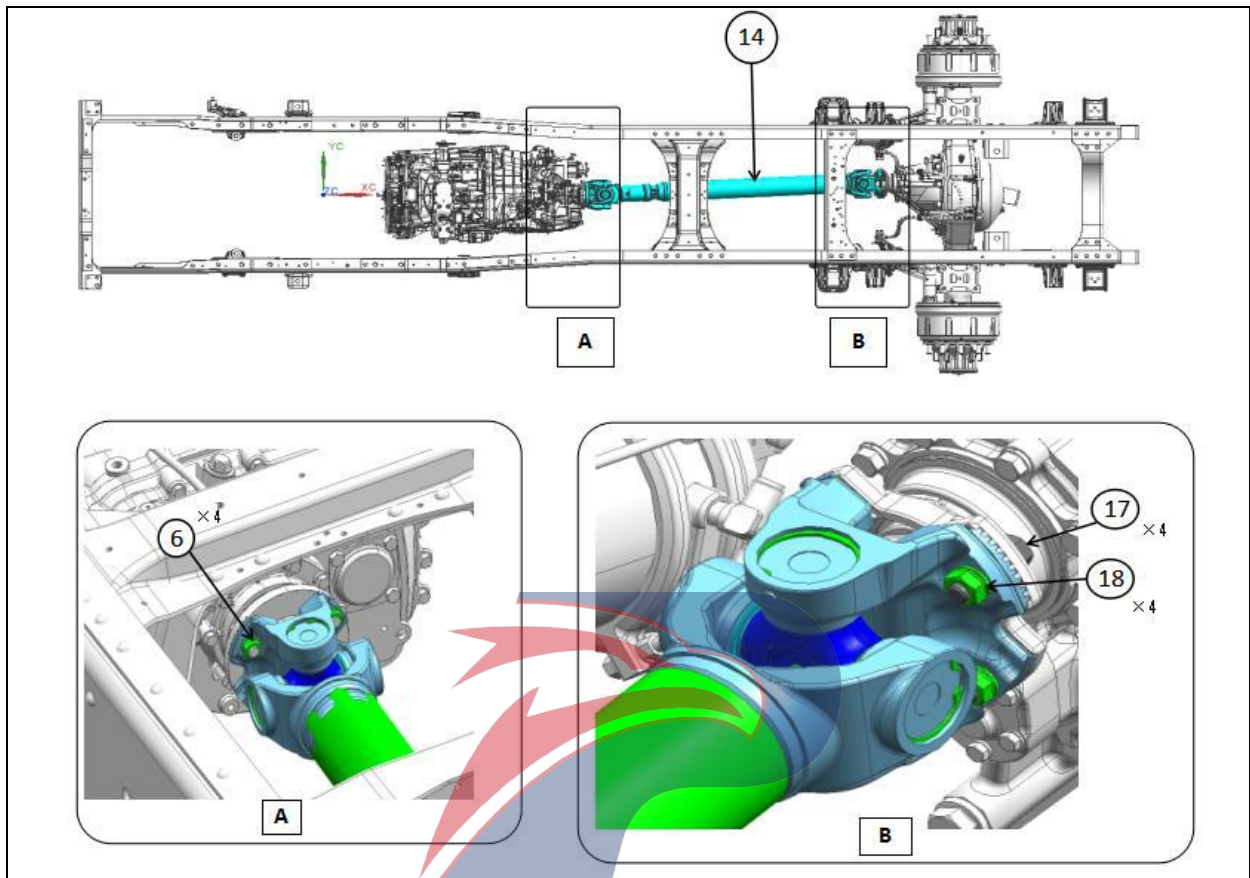

Assembly requirements:

1. Connect and tighten the drive shaft assembly 14 with bolt 17 and nuts 6 and 18 as shown in the figure.

Assembly details:

6. Nut

14. Drive shaft assembly (2201030-D15YR)

17. Bolt

18. Nut

Install the clutch friction plate assembly

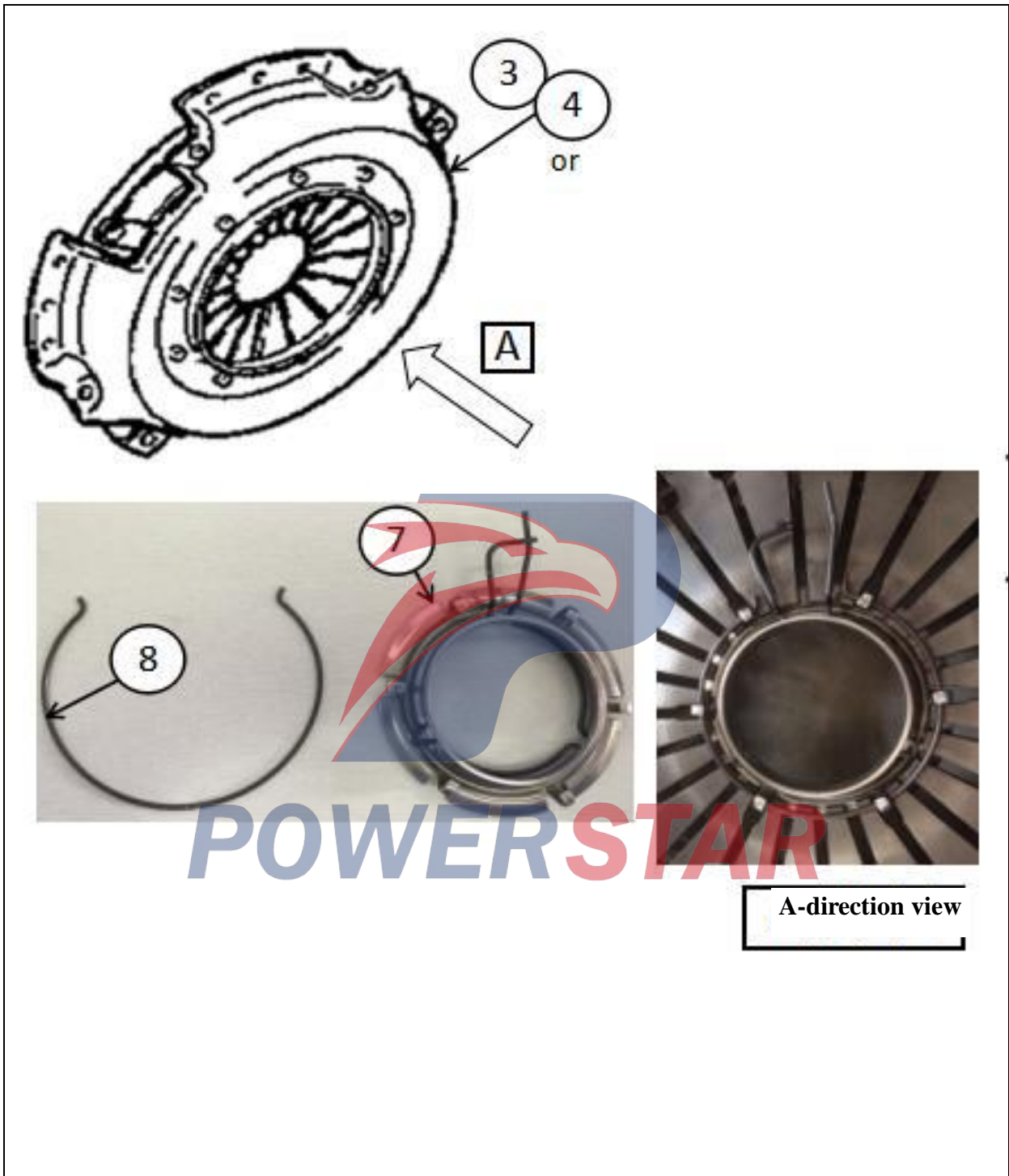

LT締付順番

17 "PULL"

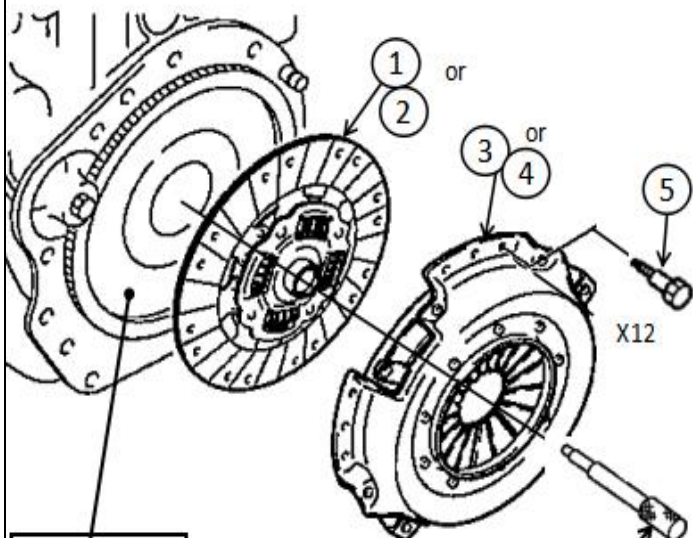
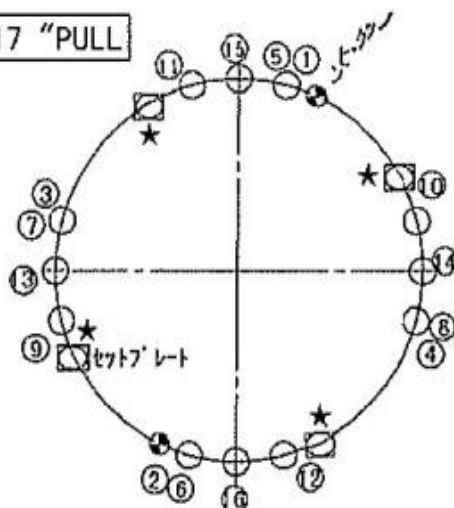

FLYWHEEL

ライナー

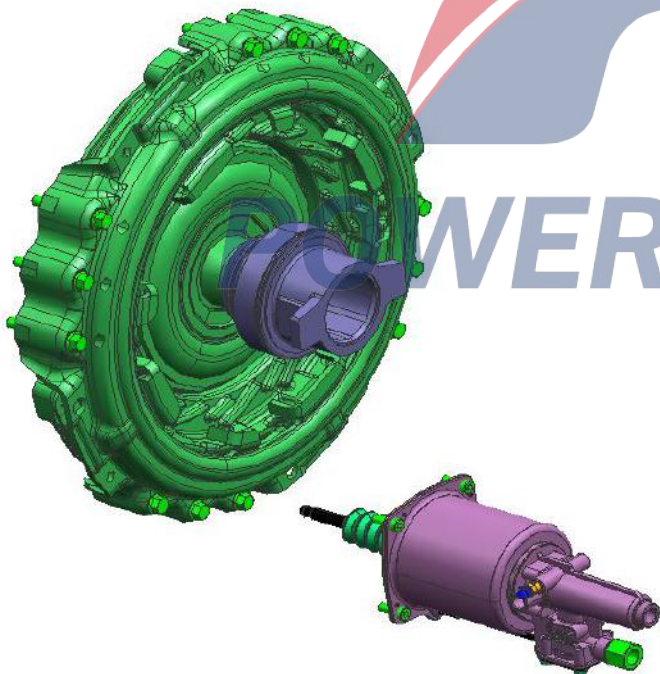

OWERSTAR

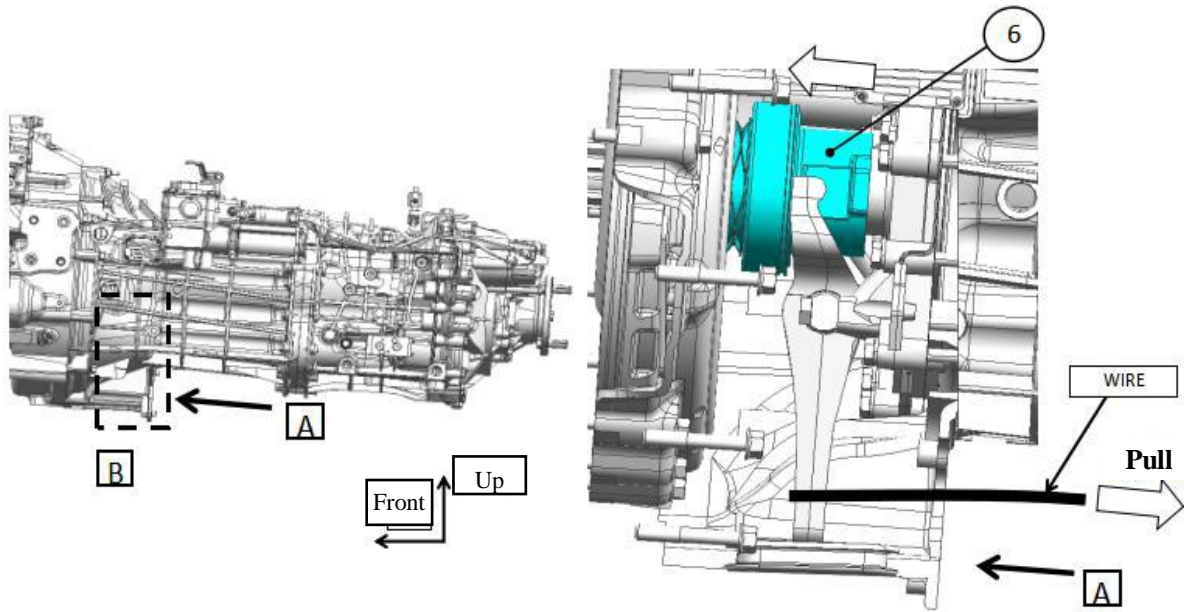

The B part section

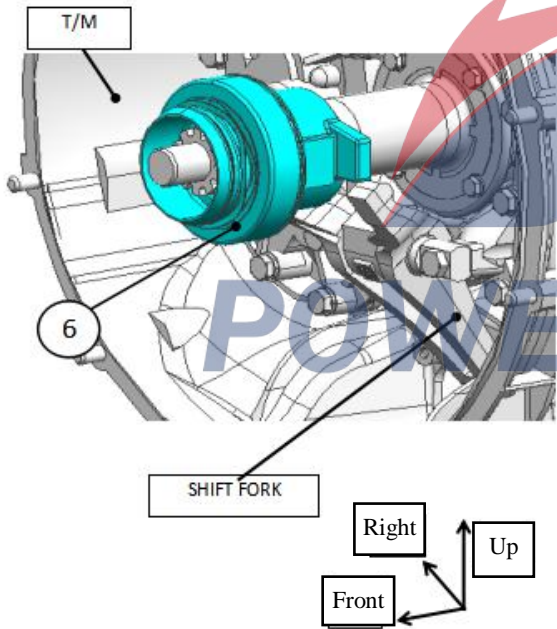

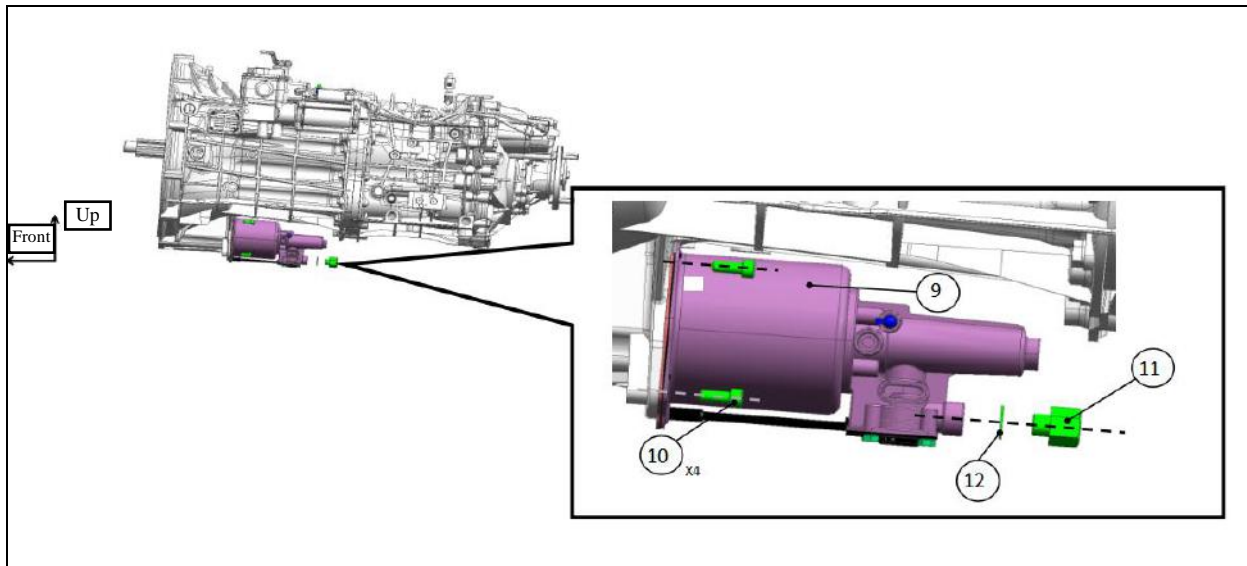

Assembly requirements:

1. Connect and tighten the clutch friction plate assemblies 1 and 2 , and clutch plate assembly 3 and 4 , and clutch release bearing 6, and support base-release bearing 7, and clamp ring-release bearing 8, and clutch sub-pump 9, and conversion adapter 11, and seal gasket 12 with bolt 5 and 10 as shown.

Assembly details:

1. Clutch friction plate assembly (1601060-D15YR)(6U)
2. Clutch friction plate assembly (1601060-D17YZ)(6W)
3. Clutch pressure plate assembly (1601040-D15YR)(6U)
4. Clutch pressure plate assembly (1601040-D17YZ)(6W)
5. Bolt (Q1841070)
6. Clutch release bearing (1601050-D17YZ)
7. Support base-release bearing (1601061-D17YZ)
8. Clamp ring -release bearing (1601062-D17YZ)
9. Clutch sub-pump (1604020-D17YZ)
10. Bolt (Q1840820)
11. Conversion adapter (1604031-D17YZ)
12. Seal gasket (1604039-D17YZ)

POWERSTAR

Install the battery assembly

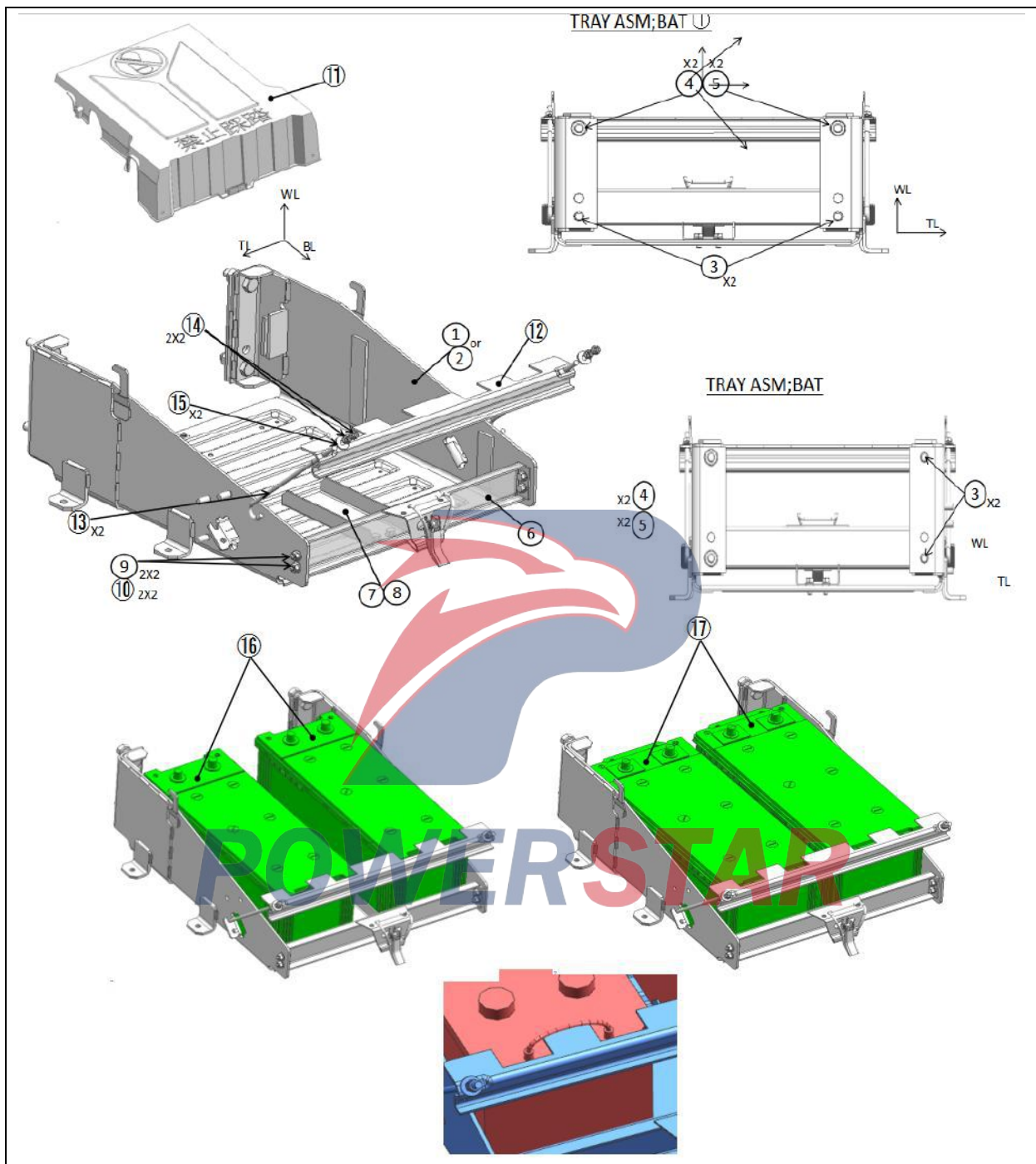

Assembly requirements:

1. Connect and tighten the battery assemblies 16 and 17, and battery cover 11, and front bezel 6, and supports 1 and 2, and support 12 with bolts and nuts 3, 4, 8, 9, 13 and 14, and spring washer 5, and gasket 7, and washer 15 as shown.

Assembly details:

1. Support (3703130-D34EZ)
2. Support (3703130-D17YZ)
3. Bolt

4. Nut
5. Spring washer (Q40314)
6. Front bezel
7. Gasket
8. Bolt (Q1840816)
9. Bolt (Q1840820)
- 10 Nut (Q32008)
11. Battery cover (3703151-D17YZ)
12. Support
13. Bolt
14. Nut (Q340B08)
15. Washer (Q40208)
16. Battery assembly
17. Battery assembly

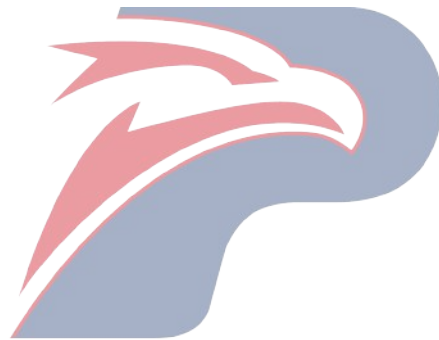

POWERSTAR

Install connector

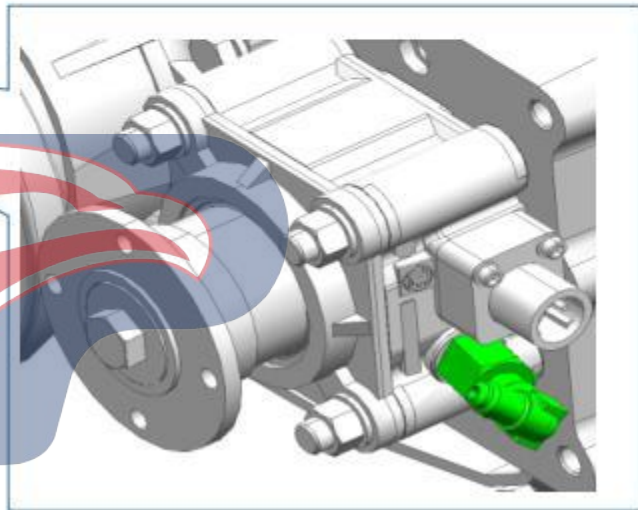
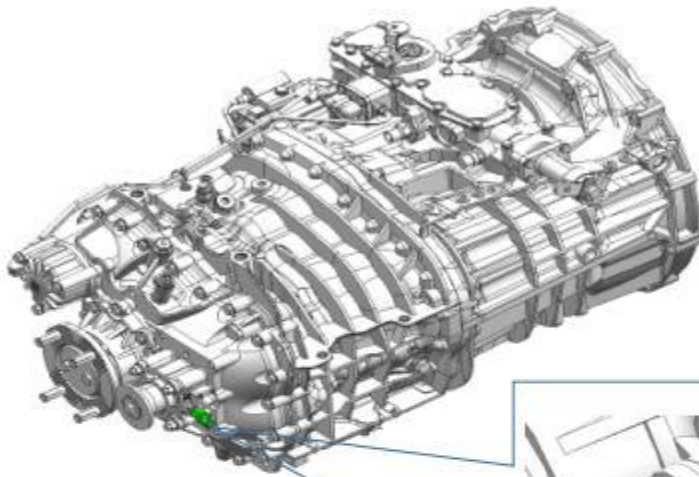

POWERSTAR

組付け角度

コネクタ取り付け向きは、下図の通りです。
(車輦後方 斜め45°)

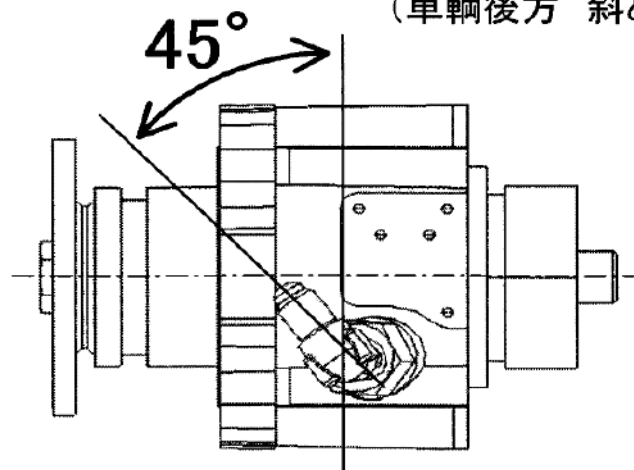

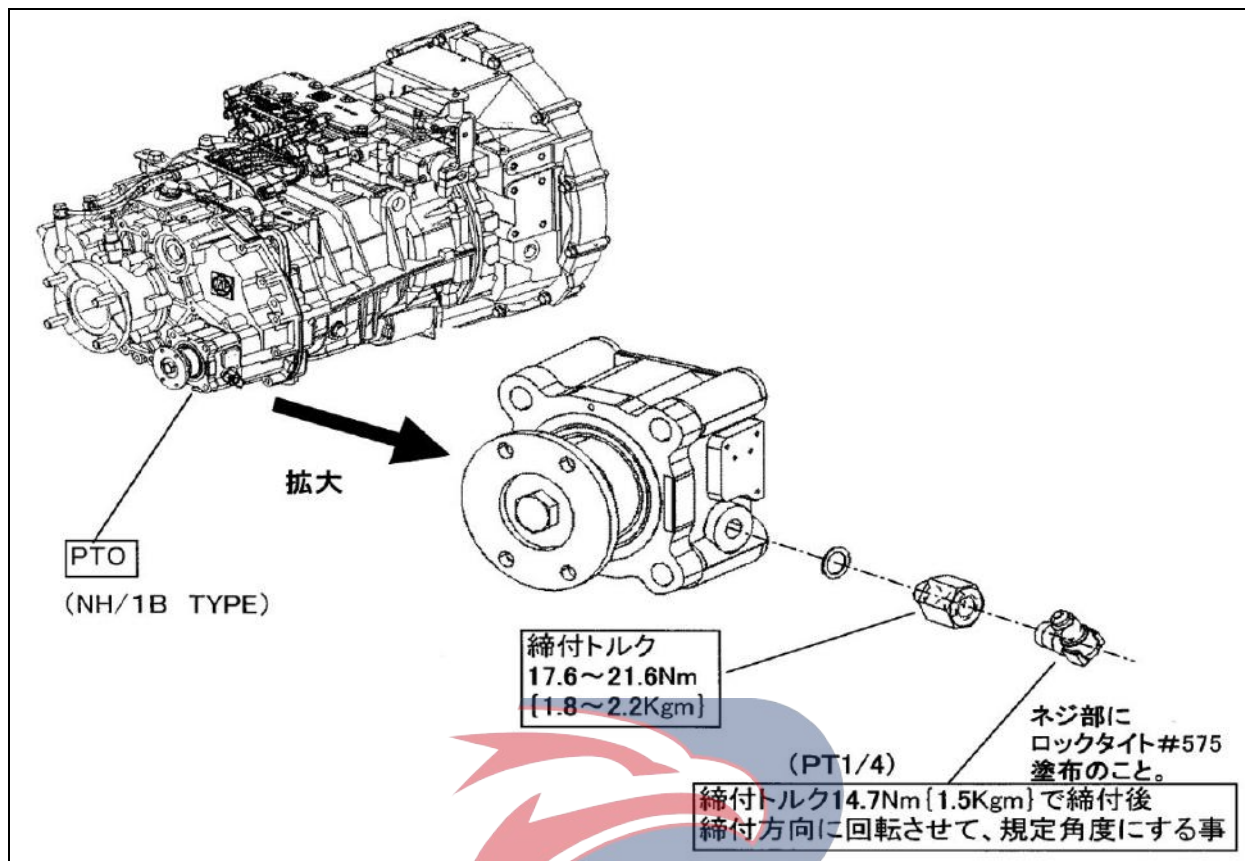

Assembly requirements:

1. Connect and tighten the connectors 1 and 2 ,and liner 3 as shown in the figure.

Assembly details:

1. Connector
2. Connector (1703253-D17YZ)
3. Liner (3506271-D17YZ)

POWERSTAR

Support-exhaust brake valve

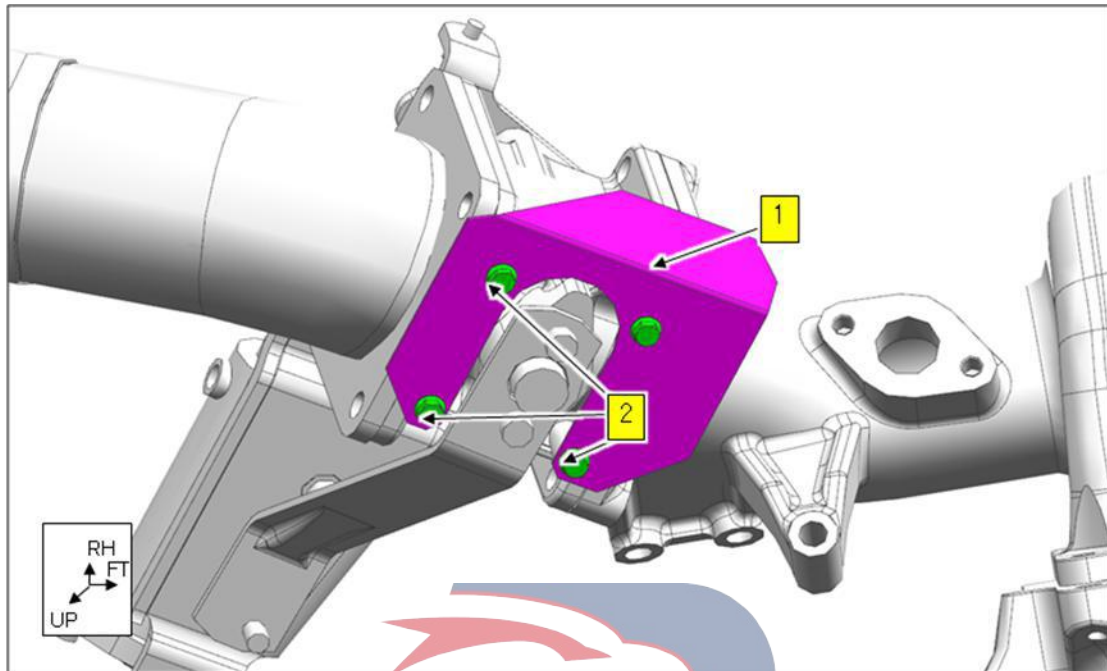

Assembly requirements:

1. Insert bolt ② through the mounting hole corresponding to the support ① and exhaust brake valve, and tighten bolt ② with a pneumatic wrench and socket wrench.

Assembly details:

1. Cover - shift
2. Bolt Q1840616

POWERSTAR

Brake hose support

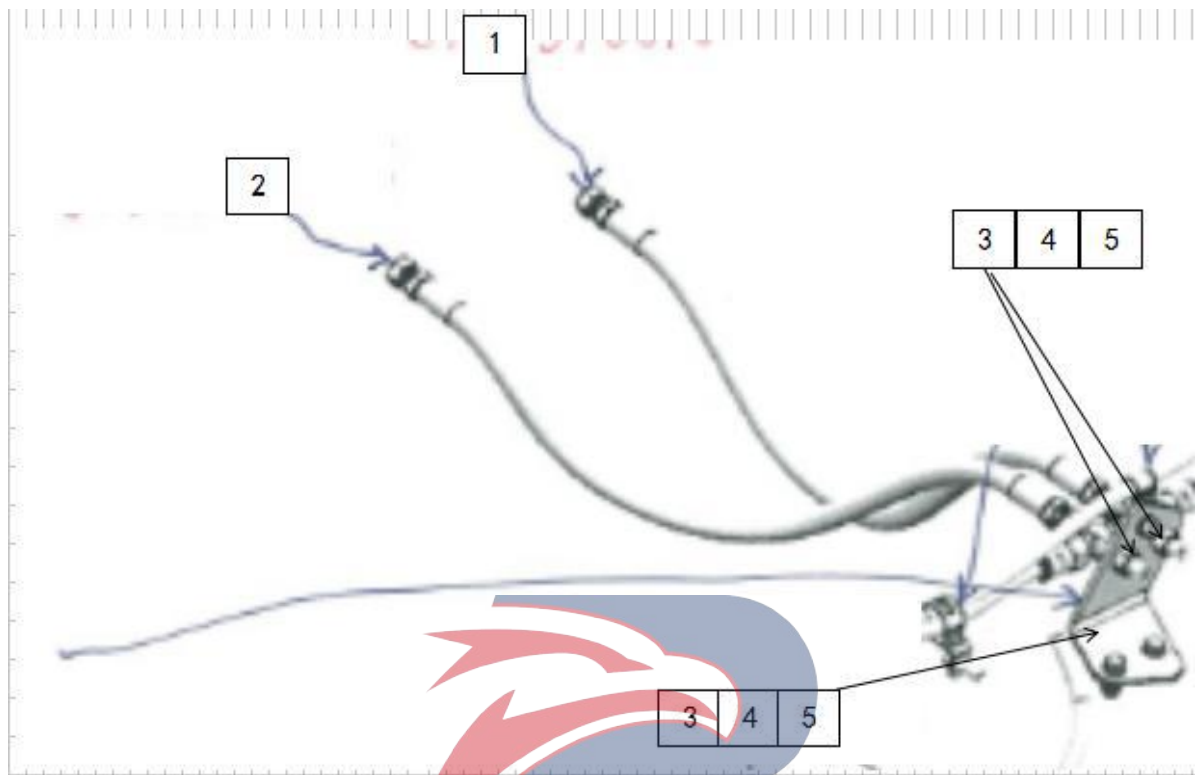

Assembly requirements:

1. Assemble parts (1), (2), (3), (4), (5), (6), (7) and (8) as shown in the figure.

Assembly details:

1. Hose assembly (3506182-D15YR)
2. Hose assembly (3506183-D15YR)
3. Connector
4. Nut (Q341B20)
5. Spring washer (Q40320)
6. Support (3506184-D15YR)
7. Bolt (Q1840825)
8. Nut (Q32008)

Fit the leaf spring buffer block

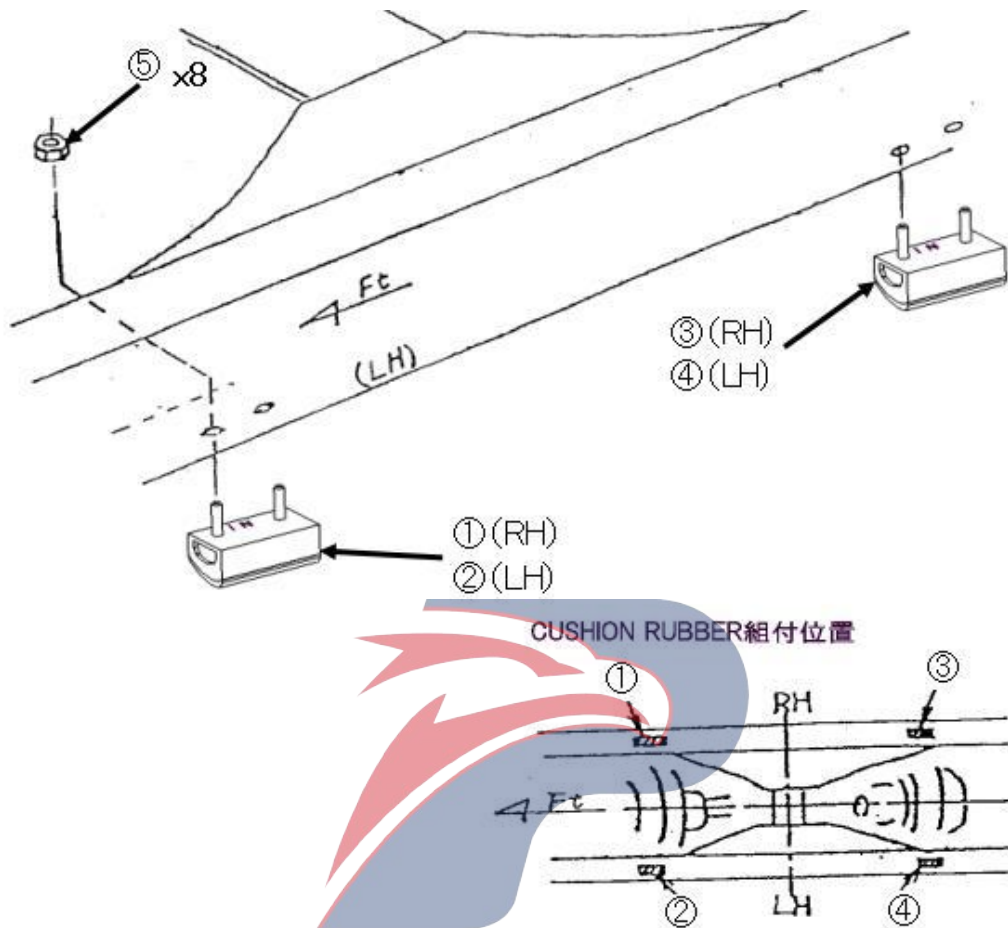

Assembly requirements:

1. Fit the buffer blocks ①, ②, ③ and ④ onto the frame, screw nut ⑤ by a few threads, and then tighten them with a pneumatic wrench tightly and reliably;

Torque of nut ⑤: 95~117N•m.

Assembly details:

1. Buffer block (2912297-D17YZ)
2. Buffer block (2902260-117)
3. Buffer block (2902260-117)
4. Buffer block (2912297-D17YZ)
5. Nut (Q32012T13F2)

Fit the U-shaped bolt and shock absorber assembly

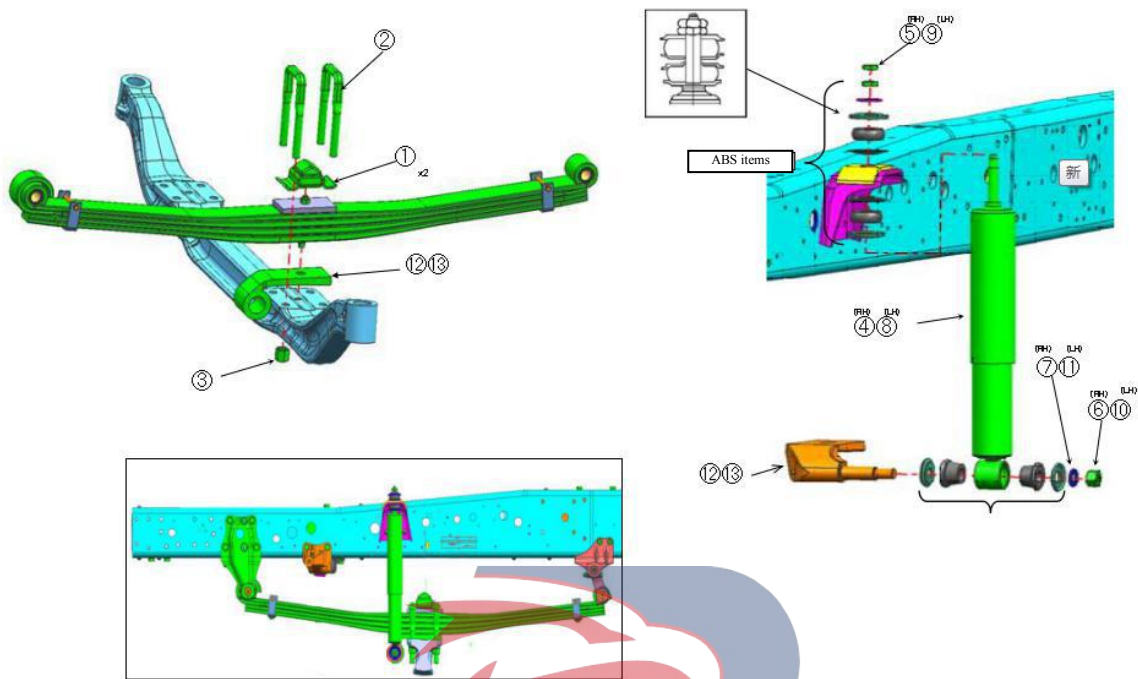

Assembly requirements:

1. Place the platen ① under the leaf spring, and fix it with U-shaped bolt ②, U-shaped bolt-nut ③, and then tighten them with a tightening machine; torque of U-shaped bolt-nut: 491~588N•m;
2. Fix the shock absorbers ④ and ⑧ onto the support-shock absorber with nuts ⑤, ⑥, ⑨ and ⑩ as well as washers ⑦ and ⑪, and finally tighten them with a pneumatic wrench tightly and reliably.

Assembly details:

1. Platen-U-shaped bolt
1. Platen-U-shaped bolt
2. U-shaped bolt
3. Nut -U-shaped bolt
4. Shock absorber assembly
5. Nut (Q351B14T15)
6. Nut (3501811-15)
7. Washer (Q40020)
8. Shock absorber assembly
9. Nut (Q351B14T15)
10. Nut (3501811-15)
11. Washer (Q40020)
12. Support-shock absorber
13. Support-shock absorber

The saddle and rear fender assembly (EXZ)

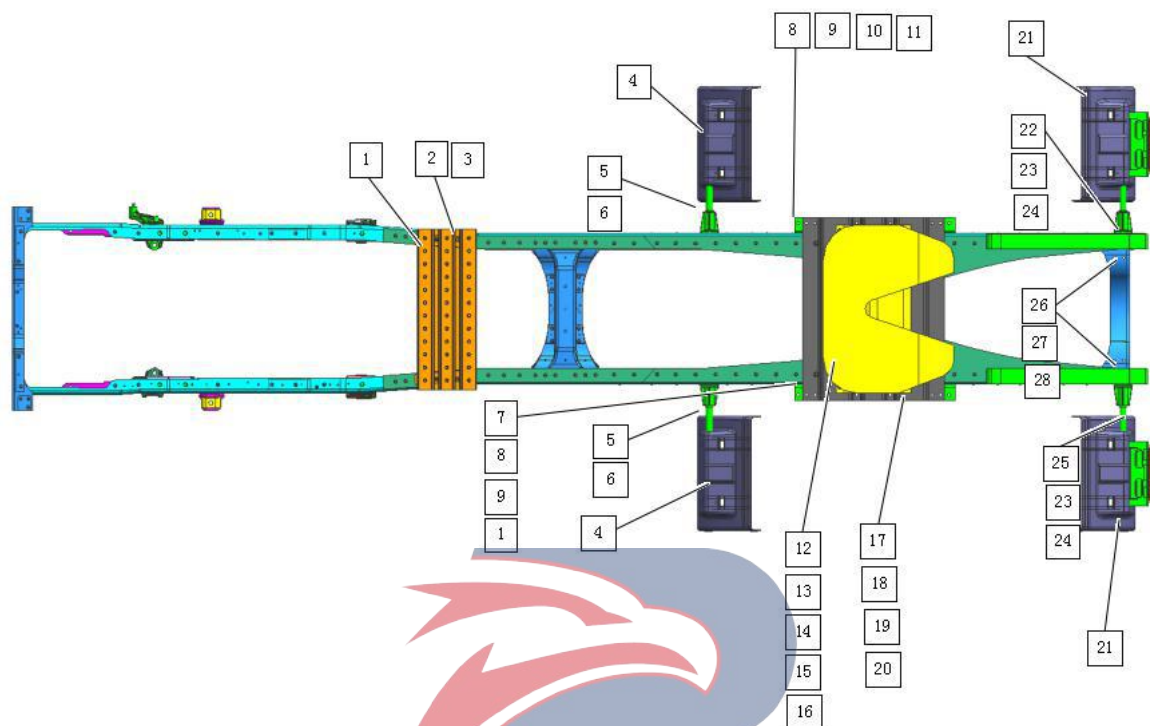

Assembly requirements:

1. Assemble the platform ① and fix it to the frame with the bolt ② and the nut ③, and finally fix it with a pneumatic wrench.
2. Assemble the saddle supports ⑦ and ⑪, fix them on the frame with the bolt ⑧, the nut ⑨ and the flat washer ⑩, and finally fix them further with a pneumatic wrench;
3. Assemble the front fender assembly, fix the rear fender support ⑤ on the frame using the bolt (6), then fix the fender ④ on the frame ⑤, and finally fix it further;
4. Assemble the corrugation plate assembly ⑰, fix it to the supports ⑦ and ⑪ using the bolt ⑬, the nut ⑭, the spring washer ⑮, and the flat washer ⑯, and finally, fix it using a pneumatic wrench;
5. Assemble the saddle assembly ⑫, fix it to the corrugation plate ⑰ using the bolt ⑬, the nut ⑭, the spring washer ⑮, and the flat washer ⑯, and finally, fix it using a pneumatic wrench;
6. Assemble the rear fender assembly, fix the support to the frame using bolts, fix the fender assembly to the support, and finally, fix it using a pneumatic wrench.

Assembly details:

1. Platform (8200260-D17YZ)
2. Bolt (Q1840830)
3. Nut (Q32008)
4. Fender (5101071-D17YZ)
5. Rear fender support (8206170-CYR14)
6. Bolt (Q1841230)
7. Saddle support plate - left (8200061-D15YR)

8. Bolt (Q151B1645T)
9. Nut (Q361C16)
10. Washer (Q40316F9)
11. Saddle support plate- right (8200062-D15YR)
12. Saddle assembly
13. Bolt (Q150B1655TF2)
14. Nut (Q361B16)
15. Spring washer (Q40116)
16. Flat washer (Q40316F9)
17. Corrugated plate
18. Bolt (Q151B1650T)
19. Nut (Q361B16)
20. Flat washer (Q40316F9)
21. Rear fender assembly (5101072-D17YZ)
22. Support (8206180-CYR14)
23. Bolt (Q1841216)
24. Bolt (Q1841225)
25. Support (8206190-CYR14)
26. Rear fender support (8206180-CYR14)
27. Bolt (Q1841230)
28. Nut (Q32012)

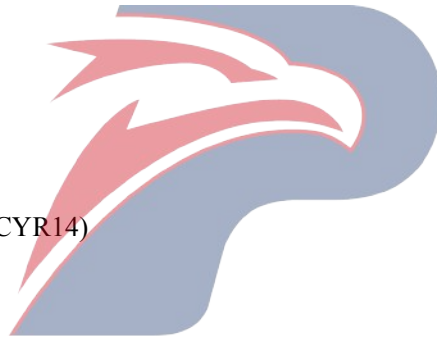

POWERSTAR

The saddle and rear fender assembly (EXR)

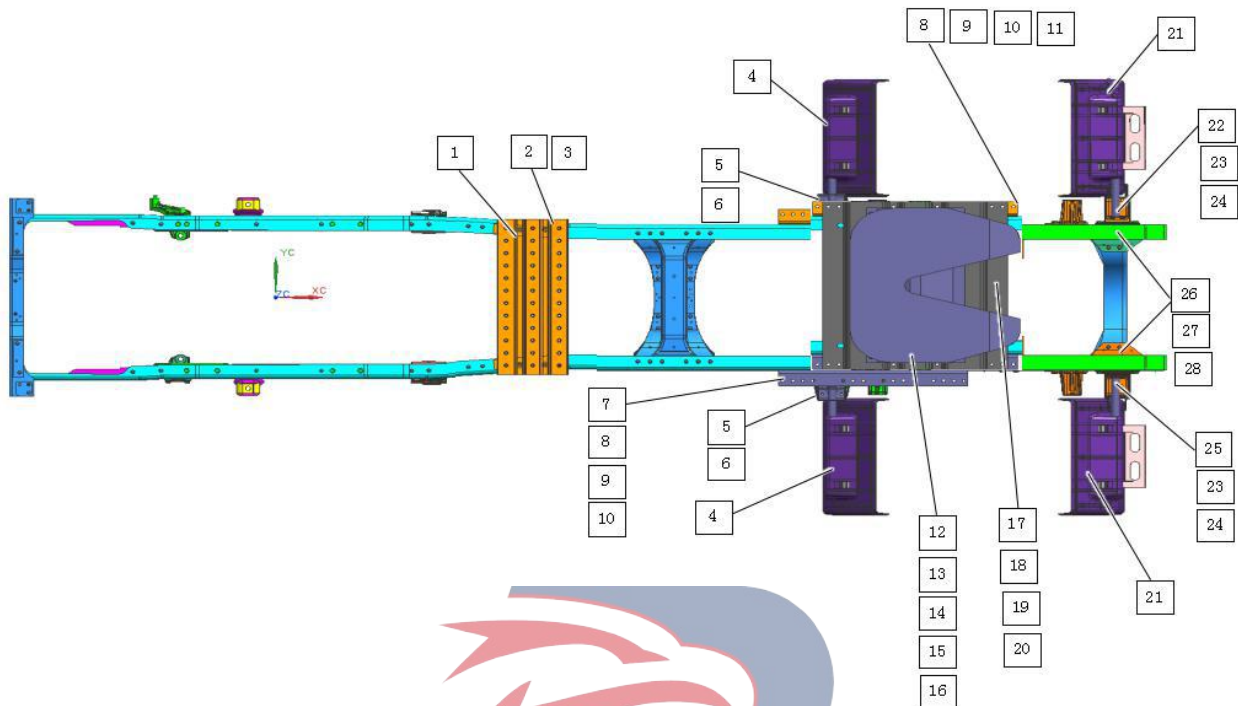

Assembly requirements:

1. Assemble the platform ① and fix it to the frame with the bolt ② and the nut ③, and finally fix it with a pneumatic wrench.
2. Assemble the saddle supports ⑦ and ⑪, fix them on the frame with the bolt ⑧ and the nut ⑨ and the flat washer ⑩, and finally fix them further with a pneumatic wrench;
3. Assemble the front fender assembly, fix the rear fender support ⑤ on the frame using the bolt ⑥, then fix the fender ④ on the frame ⑤, and finally fix it further;
4. Assemble the corrugation plate assembly ⑰, fix it to the supports ⑦ and ⑪ using the bolt ⑬, the nut ⑭, the spring washer ⑮, and the flat washer ⑯, and finally, fix it using a pneumatic wrench;
5. Assemble the saddle assembly ⑫, fix it to the corrugation plate ⑰ using the bolt ⑬, the nut ⑭, the spring washer ⑮, and the flat washer ⑯, and finally, fix it using a pneumatic wrench;
6. Assemble the rear fender assembly, fix the support to the frame using bolts, fix the fender assembly to the support, and finally, fix it using a pneumatic wrench.

Assembly details:

1. Platform ((8200260-D17YZ)
2. Bolt (Q1840830)
3. Nut (Q32008)
4. Fender (5101071-D17YZ)
5. Rear fender support (8206170-CYR14)
6. Bolt (Q1841230)
7. Saddle support plate - left (8200061-D15YR)
8. Bolt (Q151B1645T)

9. Nut (Q361C16)
10. Washer (Q40316F9)
11. Saddle support plate - right (8200062-D15YR)
12. Saddle assembly
13. Bolt (Q150B1655TF2)
14. Nut (Q361B16)
15. Spring washer (Q40116)
16. Flat washer (Q40316F9)
17. Corrugated plate
18. Bolt (Q151B1650T)
19. Nut (Q361B16)
20. Flat washer (Q40316F9)
21. Rear fender assembly (5101072-D17YZ)
22. Support (8206180-CYR14)
23. Bolt (Q1841216)
24. Bolt (Q1841225)
25. Support (8206190-CYR14)
26. Rear fender support (8206180-CYR14)
27. Bolt (Q1841230)
28. Nut (Q32012)

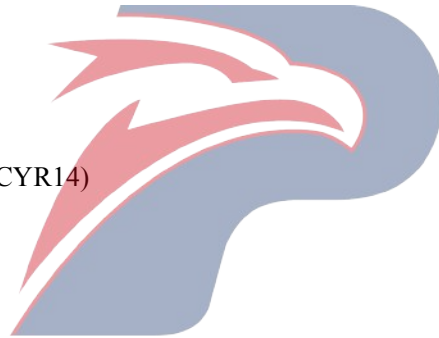

POWERSTAR

Fit the first axle leaf spring

GREASE NIPPLE組付は
3-001-02参照

※③BOLT差込方向規制なし

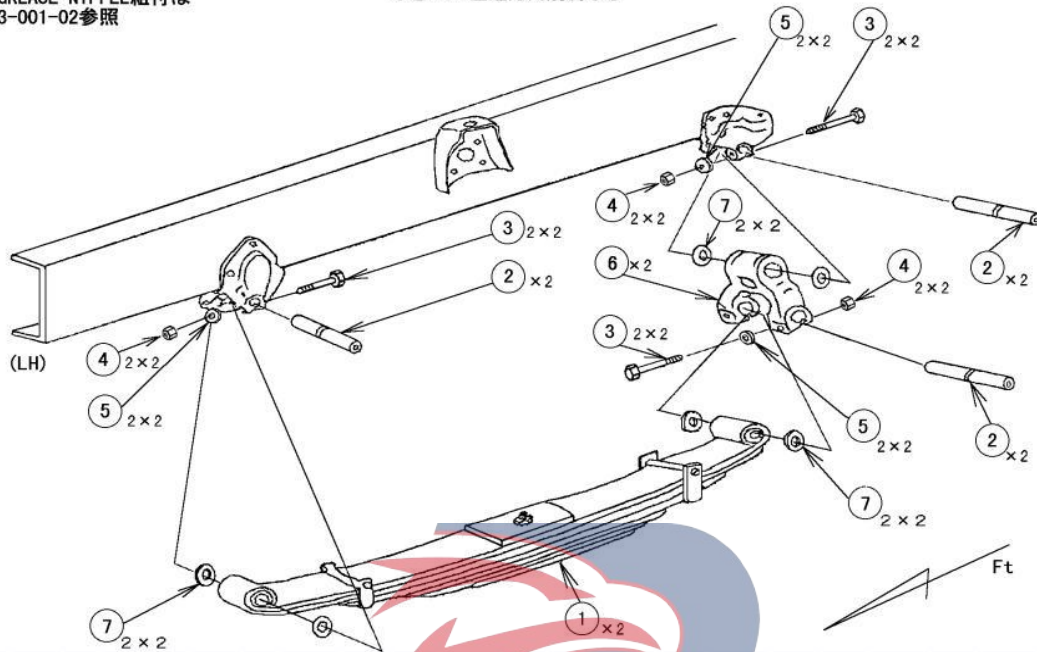

Assembly requirements:

1. Place two spring washers ⑦ on both sides of the lifting lug assembly ⑥, insert the lifting lug assembly into the mounting groove on the frame and secure it with spring pin ②.
2. Place the front leaf spring assembly ① onto the lifting lug assembly ⑥, and fix it with bolt ③, spring washer ⑤ and nut ④ tightly and reliably at a torque of 73.5~93.2N•m.

Assembly details:

1. Front leaf spring assembly

1. Front leaf spring assembly (2902010-CEZ35)

2. Spring pin (2902121-117)

3. Bolt (Q151B1280)

4. Nut (Q341B12)

5. Spring washer (Q40512)

6. Lifting lug assembly (2902130-117)

7. Spring washer

Fit the steering gear box and its attachments

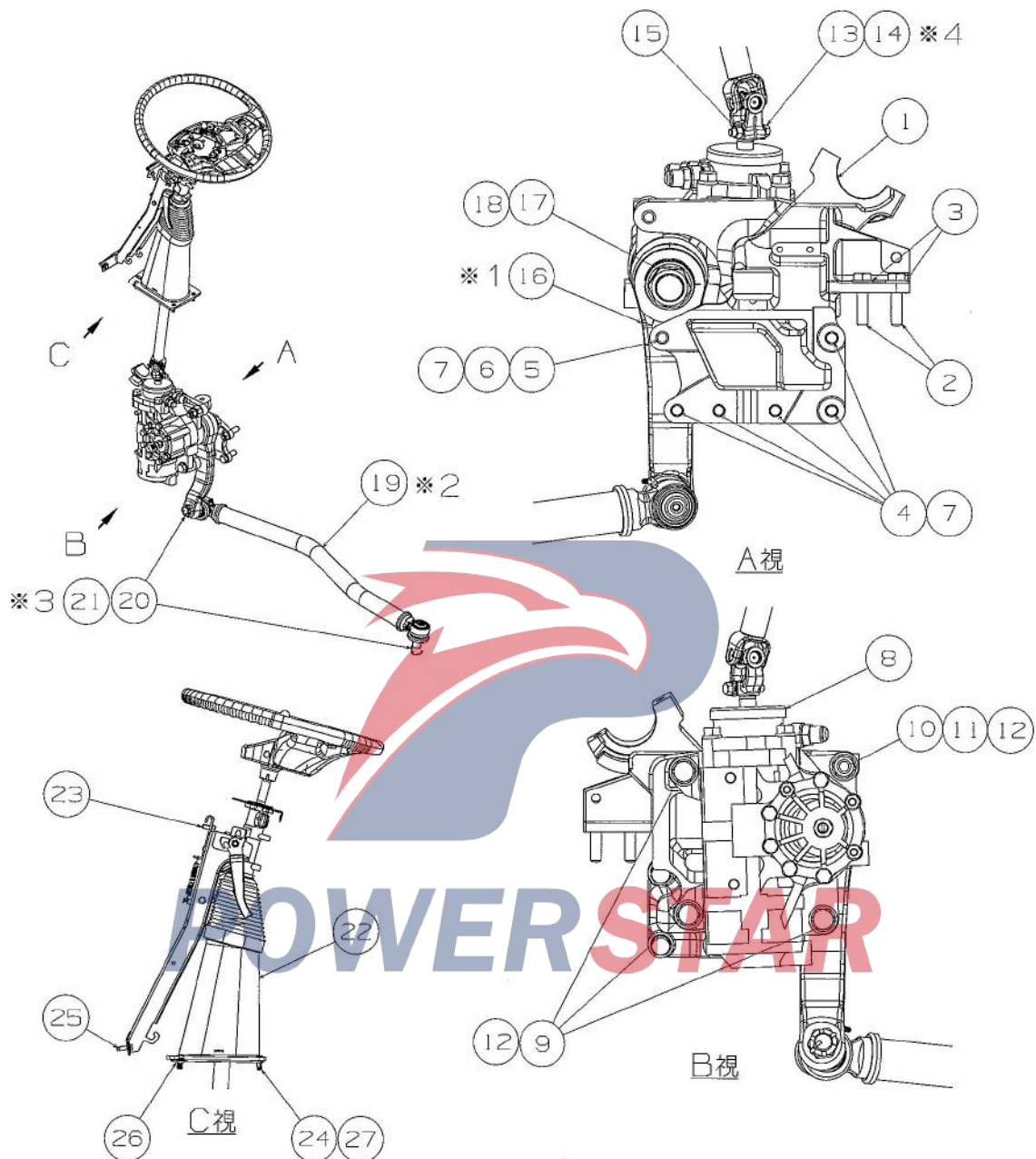

Assembly requirements:

1. Fix the support assembly ① onto the frame with bolts ②, ④ and ⑤, washers ③ and ⑦ as well as nut ⑥ at a torque of 265~314N.m;
2. Put the steering gear box assembly ⑧ onto the support assembly ①, and then fix it with bolts ⑨ and ⑩, nut ⑪, spring washer ⑭ and flat gasket ⑫.
3. tightly and reliably at a torque of 282~345N.m;
- Fix the pitman arm assembly ⑯ onto the steering gear box assembly with nut ⑰ and spring washer ⑱ at a torque of 392~490N.m;
4. Fix the drag link assembly ⑲ onto the pitman arm assembly, secure the slotted nut with cotter pin ⑳ after the slotted nut is tightened (the cotter pin should be bent reliably);
5. Finally, fix the steering column assembly with bolts, nuts and washers tightly and reliably.

Assembly details:

1. Support assembly-cab installation (5001011-D17YZ)
2. Bolt (Q151B1450TF2)
3. Washer (2801104-113)
4. Bolt (Q151B1660T)
5. Bolt
6. Nut (Q341B16)
7. Washer
8. Steering gear box assembly (3708100-CEH14)
8. Steering gear box assembly
9. Bolt
10. Bolt
11. Nut (Q341B18)
12. Washer
13. Bolt (3402051-117/C)
14. Spring washer (Q40510)
15. Nut (Q341C10)
16. Pitman arm (3003013-CEH14)
16. Pitman arm (
17. Nut
18. Spring washer (3003014-117)
19. Drag link assembly (3003020-CEH14B)
19. Drag link assembly
20. Split pin (Q5005035)
21. Split pin (Q5005035)
22. Steering column assembly (3404010-D17YZ)
23. Bolt (Q1840820)
24. Screw
25. Bolt
26. Nut
27. Washer nut (6201401-26)

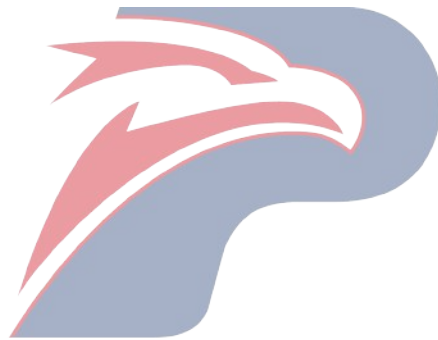

POWERSTAR

Fit the leaf spring grease nipple

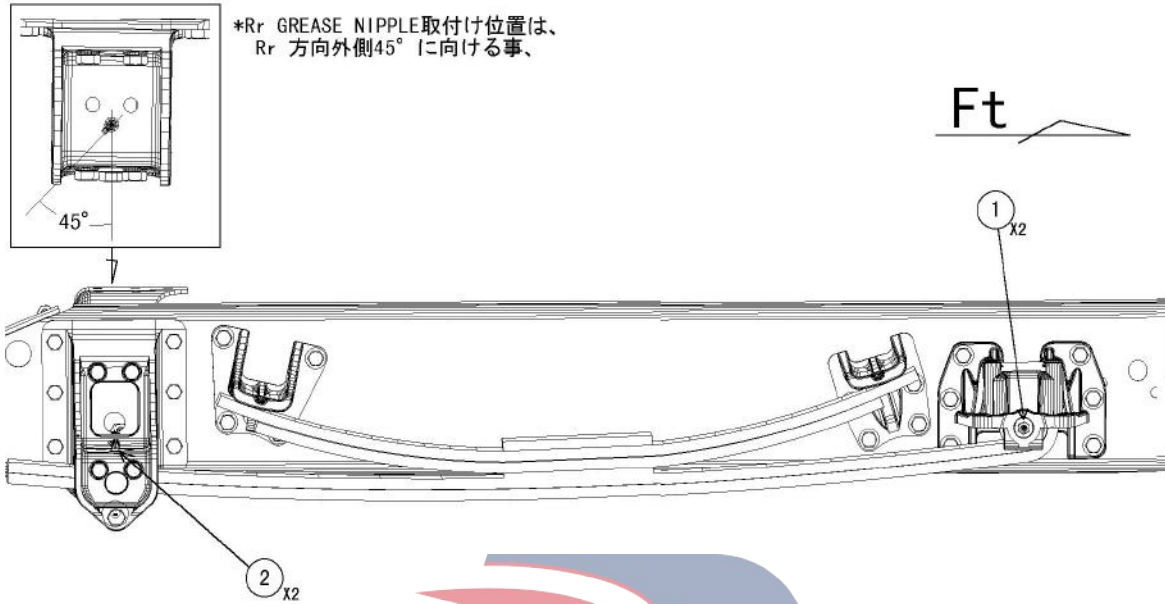

Assembly requirements:

1. Tighten the grease nipples ① and ② tightly and reliably as shown;
2. Grease nipple ② is installed at an angle of 45°.

Assembly details:

1. Grease nipple (Q701B90)
2. Grease nipple (Q701B45)

POWERSTAR

Fit the rear leaf spring assembly (EXR)

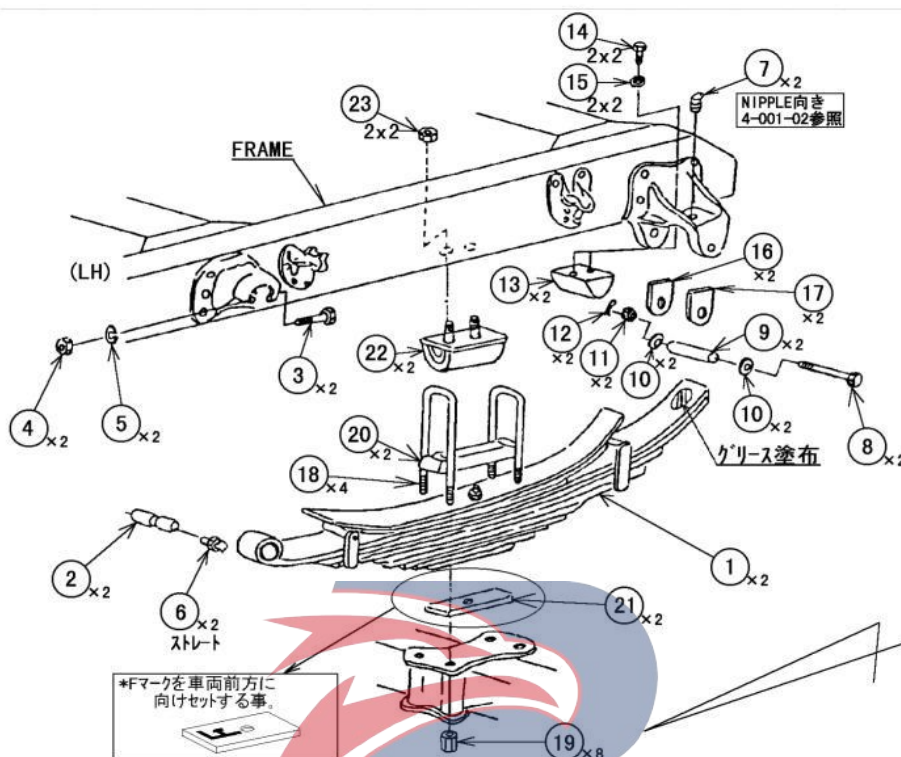

Assembly requirements:

1. Fit the rear leaf spring assembly, and fix it with gaskets, spacers, bolts, nuts, cotter pins, etc;
2. Insert the U-shaped bolt into the rear leaf spring assembly, and connect it to the rear axle assembly with spacers and nuts.

Torque of nut - U-shaped bolt: 363.0~460.0N·m

Assembly details:

1. Rear leaf spring assembly (2912010-CYR14B)
2. Pin-spring support (2912215-117)
3. Bolt (Q151B1480)
4. Nut (Q341B14)
5. Spring washer (Q40314)
6. Grease nipple (Q701B90)
7. Grease nipple (Q701B45)
8. Bolt (2902303-117/C)
9. Spacer
10. Washer (Q40114)
11. Nut (Q341B24T13)
12. Split pin (Q5003228)
13. Cushion block (2912216-117)
14. Bolt (Q151B1435T)

15. Spring washer (Q40314)
16. Gasket (2902301-117/C)
17. Gasket (2902302-117/C)
18. U-shaped fixing screw
19. Nut (Q341B24T13)
20. Cushion block (2912218-117)
21. Gasket - leaf spring (2912111-117)
22. Rubber gasket
23. Nut (Q32012T13F2)

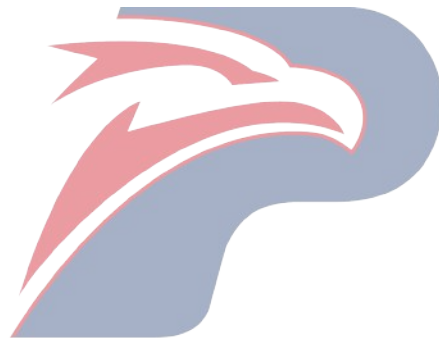

POWERSTAR

Fit the rear leaf spring assembly (EXZ)

LEAF SUSPENSION ASM組付け

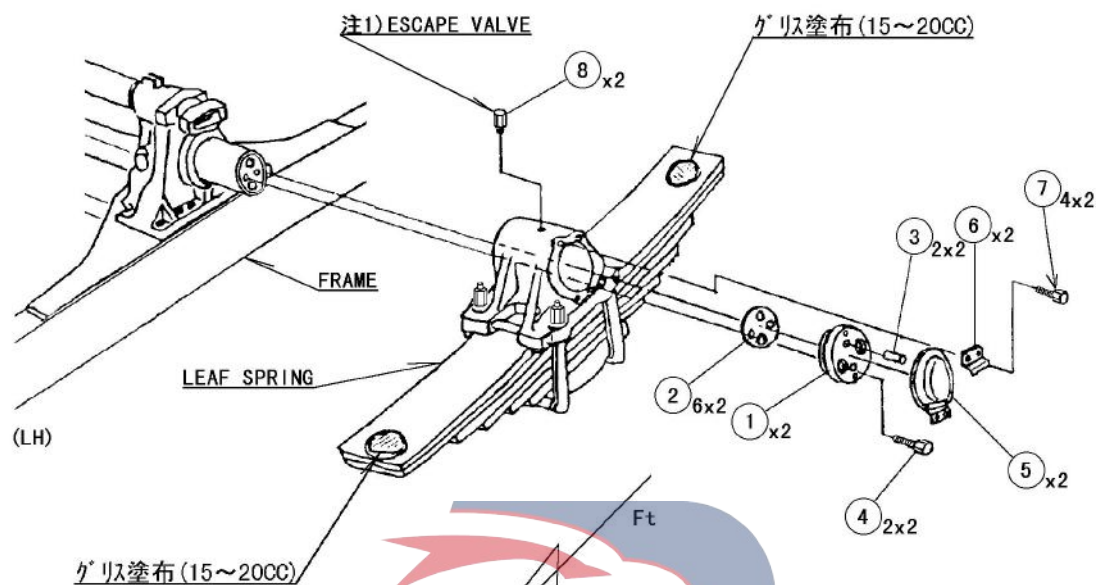

Assembly requirements:

1. Lift the rear leaf spring assembly with a crane, fix it onto the retroflexion support assembly, and secure it with gasket ②, platen ①, bolt ④ and pin ③ tightly and reliably;

Torque of bolt ④: 284~343N•m;

2. Fix the cover plates ⑤ and ⑥ with bolt ⑦ tightly and reliably;

Screw the grease nipple ⑧ into the corresponding mounting hole tightly and reliably;

Apply lithium-based grease (15-20CC) onto both ends of the leaf spring assembly.

Assembly details:

1. Platen (2912211-117)
2. Gasket
3. Pin
4. Bolt
5. Cover plate assembly (2912210-117)
6. Cover plate (2912213-117)
7. Bolt (Q1840812)
8. Grease nipple

Fit the rear plate spring seat

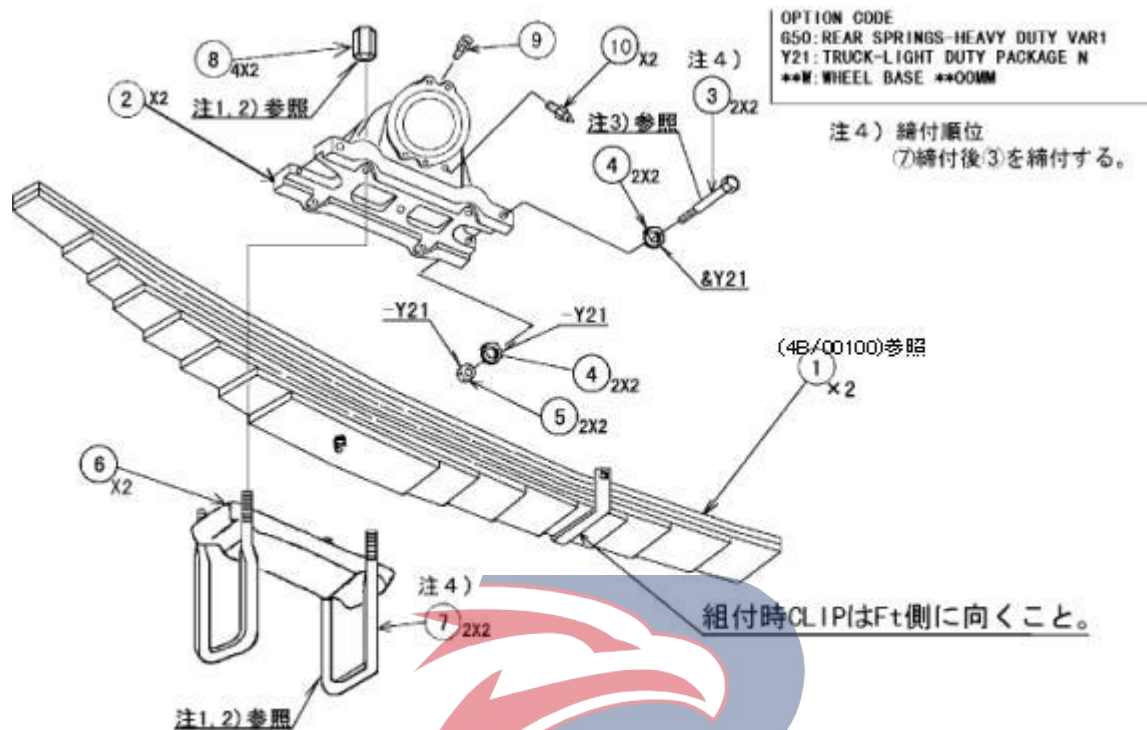

Assembly requirements:

1. Place the rear leaf spring assembly ① onto the leaf spring trolley, connect the seat assembly ②, U-shaped bolt ⑦ and liner ⑥ sequentially, then screw nut ⑧ into the U-shaped bolt, and finally tighten them tightly and reliably with a pneumatic wrench;

Torque of nut ⑧: 824~883N•m;

2. Fix it with bolt ③, spring washer ④ and nut ⑤ tightly and reliably;

3. Screw the grease nipples ⑨ and ⑩ into the corresponding mounting holes tightly and reliably.

Assembly details:

1. Rear leaf spring assembly (2912010-D17YZ)

2. Seat assembly-leaf spring

3. Bolt

4. Spring washer (Q40522)

5. Nut (Q341B22T13)

6. Liner

7. U-shaped bolt

8. Nut (2912052-130/C)

9. Grease nipple

10. Grease nipple (Q701B01)

Fit the rear axle brake nylon tube

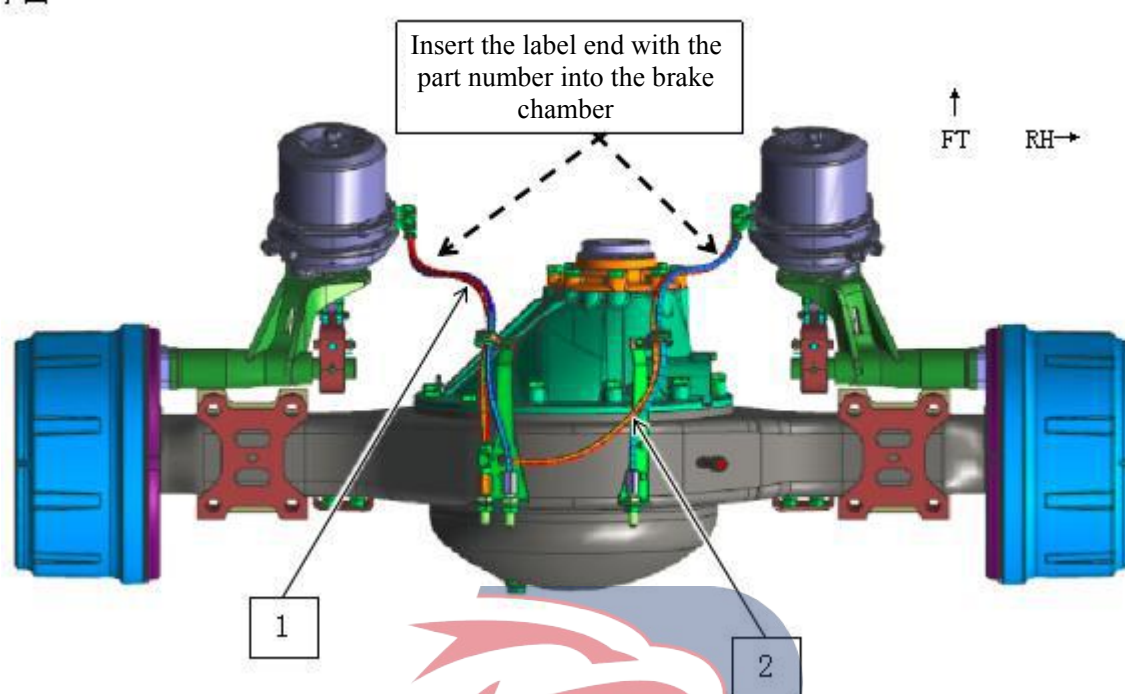

Assembly requirements:

Insert nylon tubes ① and ② into the corresponding connectors tightly and reliably.

Assembly details:

1. Nylon tube assembly-left (3506330-D15YR)
2. Nylon tube assembly-right (3506320-D15YR)

POWERSTAR

Fit the shock absorber assembly

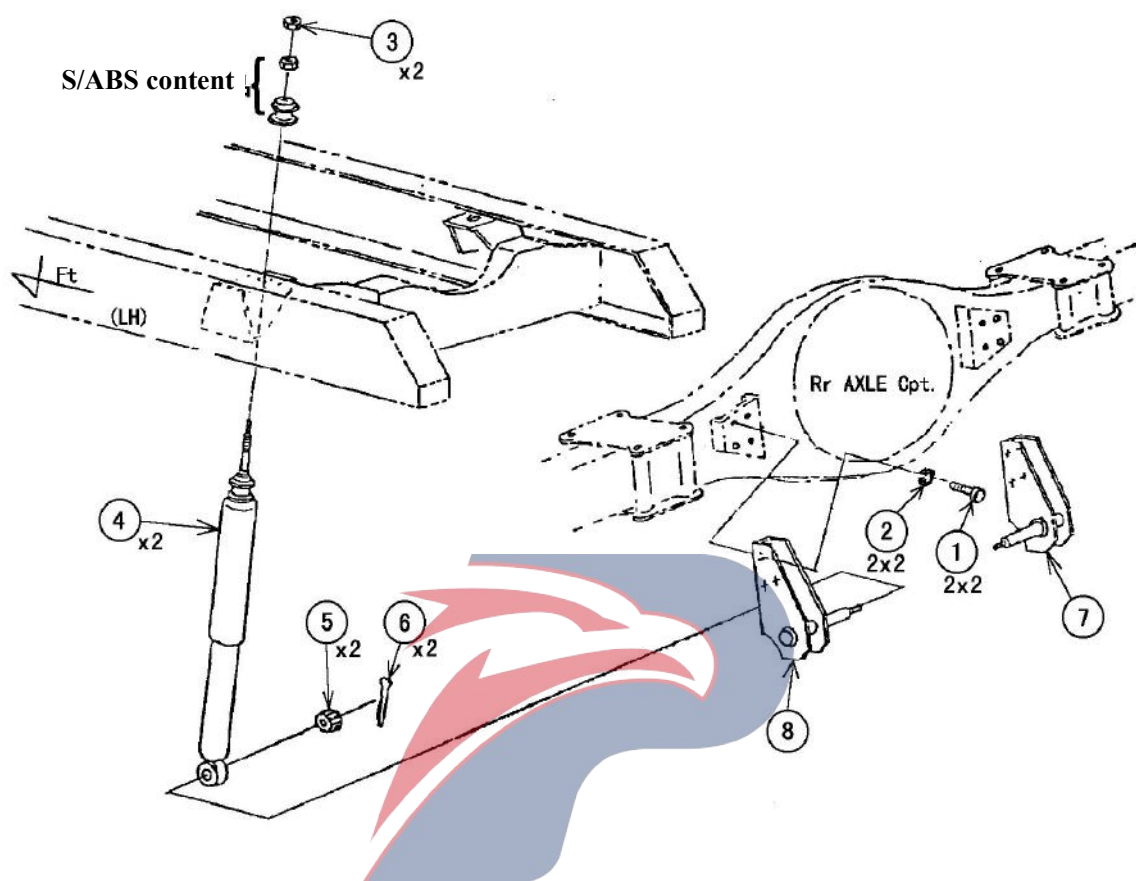

Assembly requirements:

1. Fix the shock absorber support assemblies ⑦ and ⑧ onto the axle housing with bolt ① and spring washer ② tightly and reliably;
2. Fix one end of the shock absorber assembly ④ onto the shock absorber bracket and the other end onto the frame, and then fix them with nuts ③ and ⑤ and split pin ⑥ (split pin should be reliably bent).

Assembly details:

1. Bolt (Q151B1430)
2. Spring washer (Q40514)
3. Nut (Q341B18)
4. Shock absorber assembly (1516306020)
5. Nut (9991164240)
6. Split pin (811250450)
7. Support-shock absorber (1516817160)
8. Support-shock absorber (1516817170)

Fit the front bumper assembly

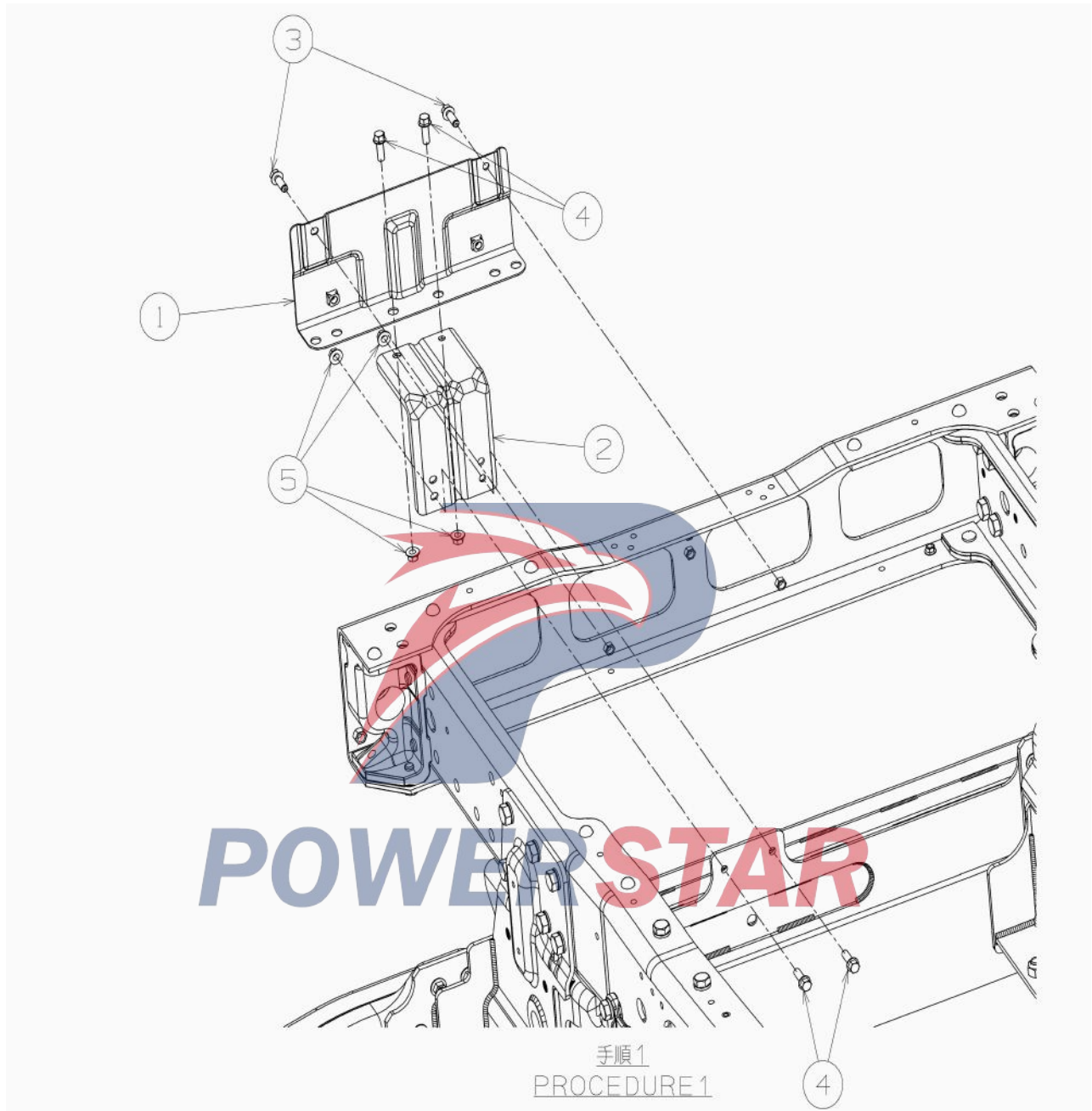

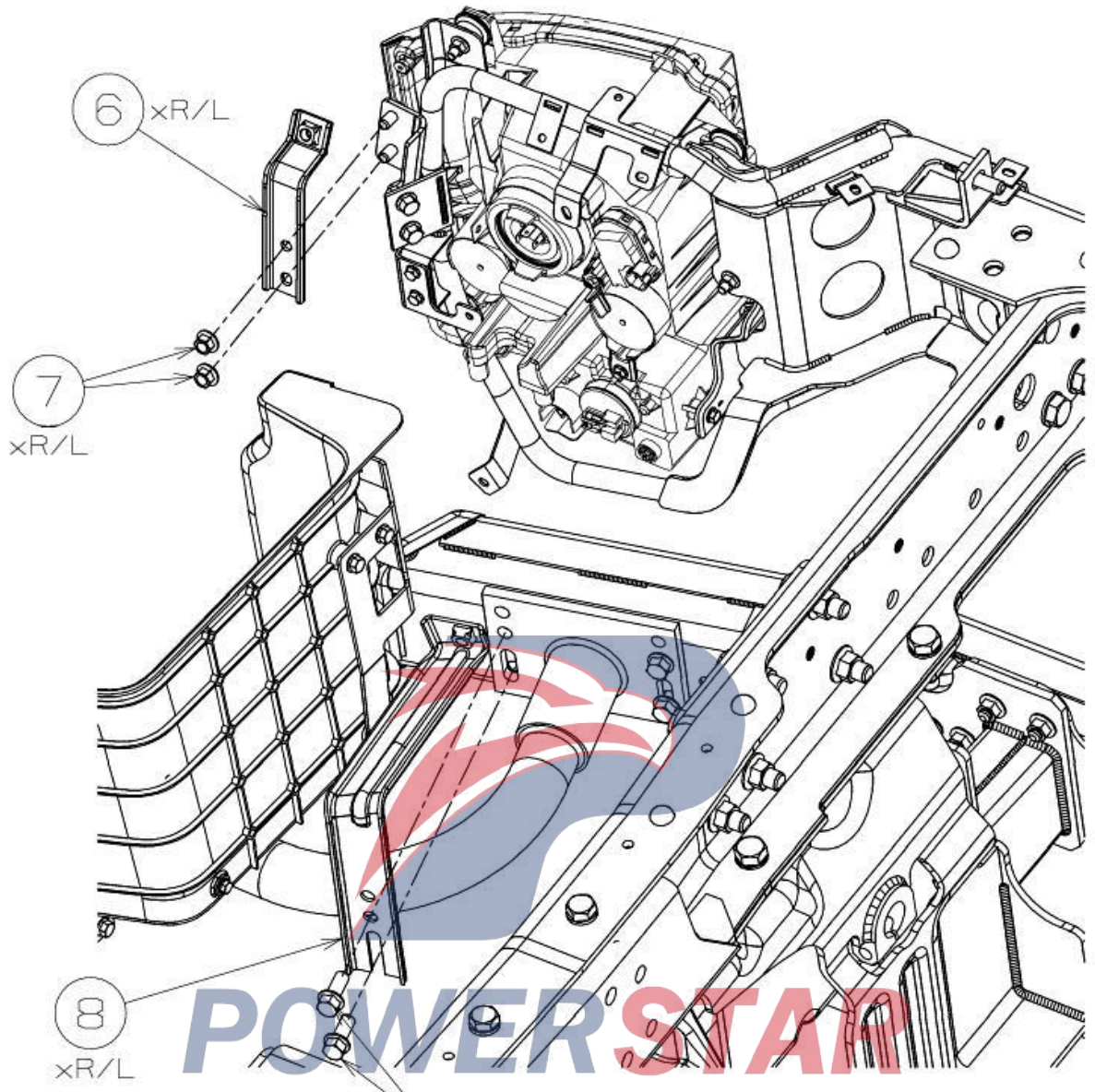

1st STEP と共締め FIXED WITH 1ST STEP
 (SEE 1st STEP INSTR DWG)

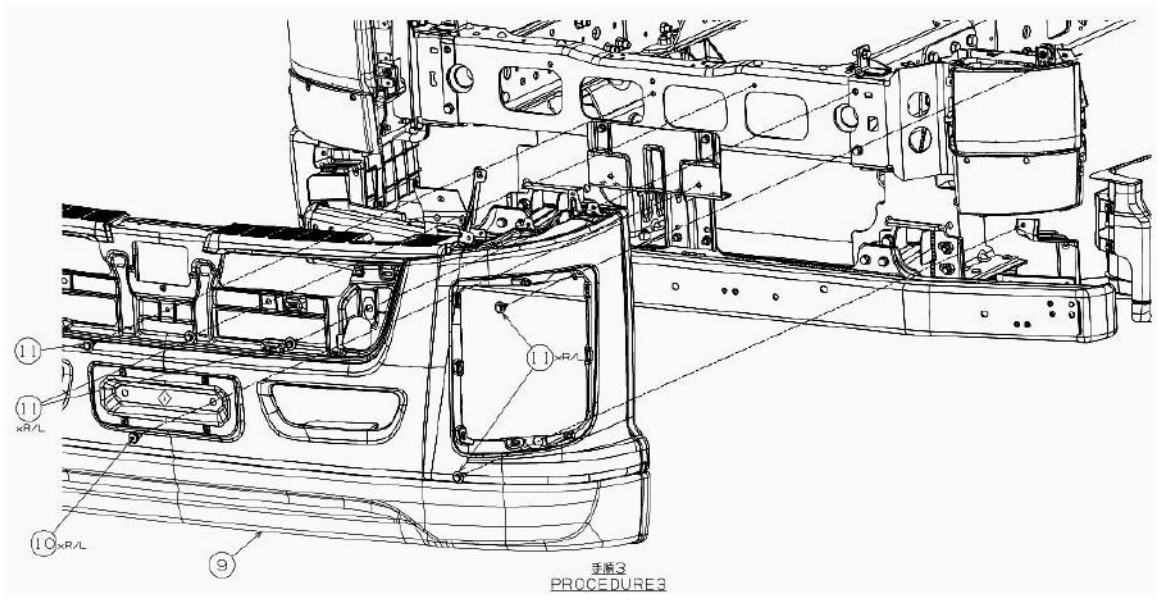

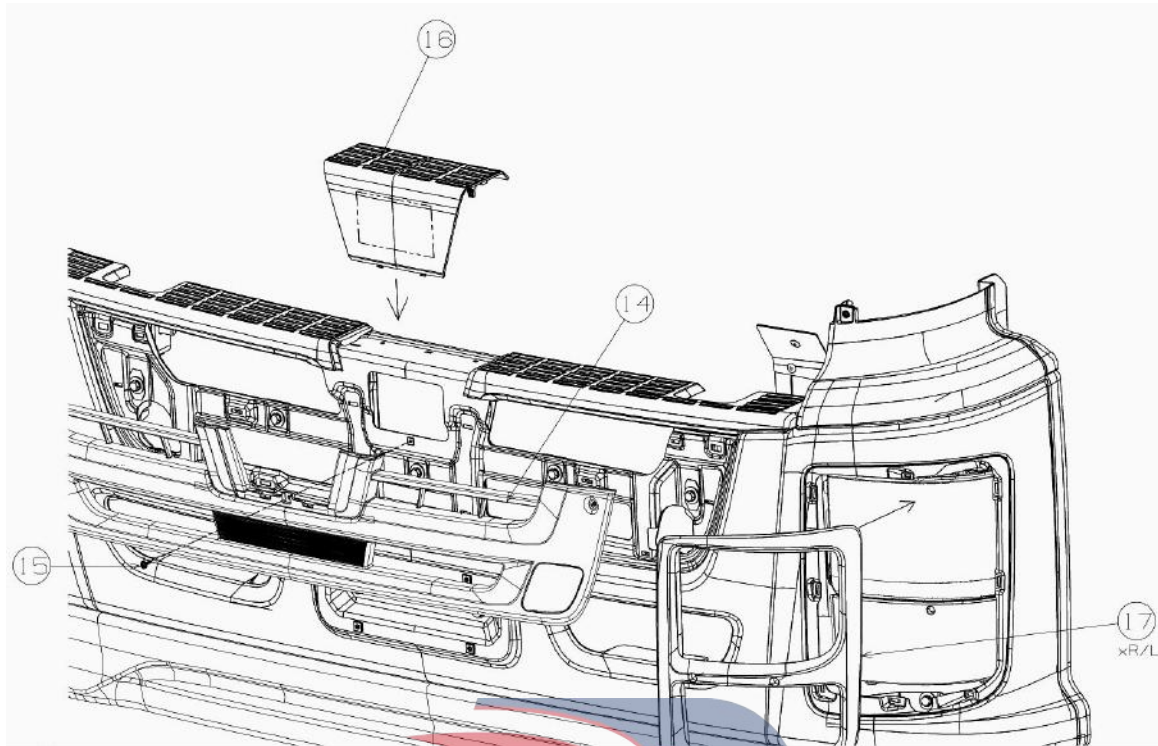

Assembly requirements:

1. Fix the support ① onto the frame with bolt ③, connect the supports ① and ② together with bolt ④ and nut ⑤, connect the support ② with the frame together with bolt ④ and nut ⑤, and finally tighten it using the pneumatic wrench tightly and reliably;
2. Flexibly connect the support ⑥ to the headlamp frame ⑦, and then tighten it after the bumper assembly is mounted;
3. Fix the support ⑧ onto the pedal assembly together, and then tighten it after the bumper assembly is mounted;
4. Fit bumper assembly ⑨. Connect the upper assembly ⑫ of front bumper with screw ⑬, and fit the grille assembly ⑭ and pedal assembly ⑯ together;
5. Fix the bumper assembly onto the frame and supports ⑥ and ⑧ with bolt ⑪, and finally tighten it with a pneumatic wrench;
6. Finally, insert the light frame assembly ⑰ into the headlamps tightly and reliably.

Assembly details:

1. Support assembly(2803035-D17YZ)
2. Support (2803036-D17YZ)
3. Bolt (Q1841030)
4. Bolt (Q1841030)
5. Nut(Q32010T13F2)
6. Support (2803037-D17YZ)
7. Nut (Q32010T13F2)
8. Support assembly 2803045-D17YZ
8. Support assembly2803046-D17YZ
9. Front bumper assembly 2803020-D17YZ

- 9. Front bumper assembly 2803030-D17YZ
- 10. Bolt 2803038-D17YZ
- 11. Bolt
- 12. Front bumper-upper assembly right 2803180-D17YZ
- 12. Front bumper-upper assembly left 2803160-D17YZ
- 13. Screw Q2204816
- 14. Grille assembly - front bumper 1301120-D17YZ
- 15. Screw Q2204816
- 16. Pedal assembly 2803150-D17YZ
- 17. Border assembly-headlamp right 2803172-D17YZ
- 17. Border assembly-headlamp left 2803171-D17YZ

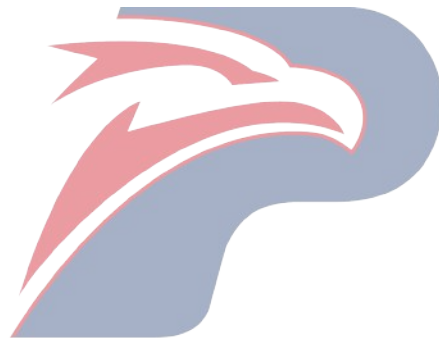

POWERSTAR

Fit the headlamp support

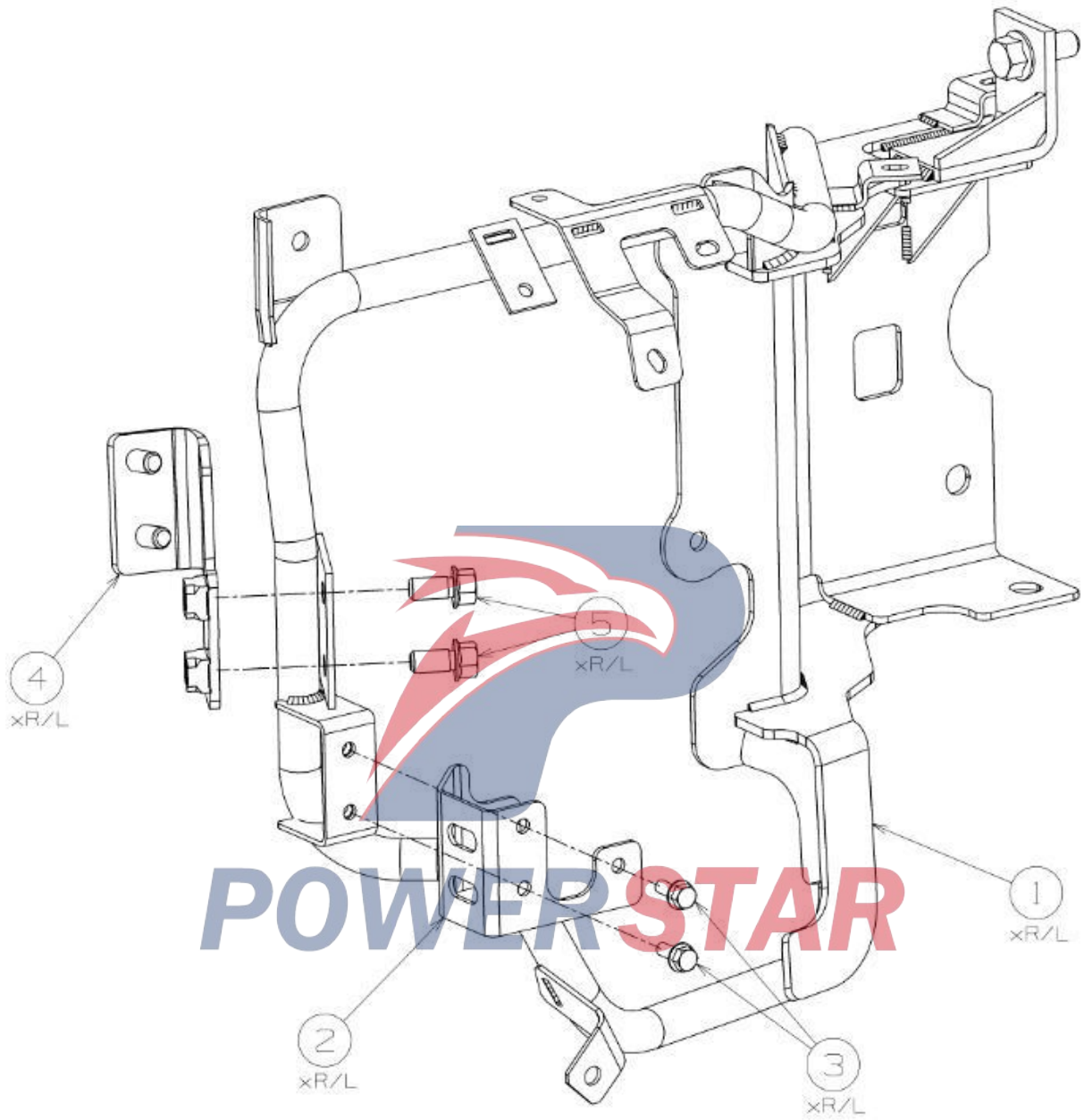

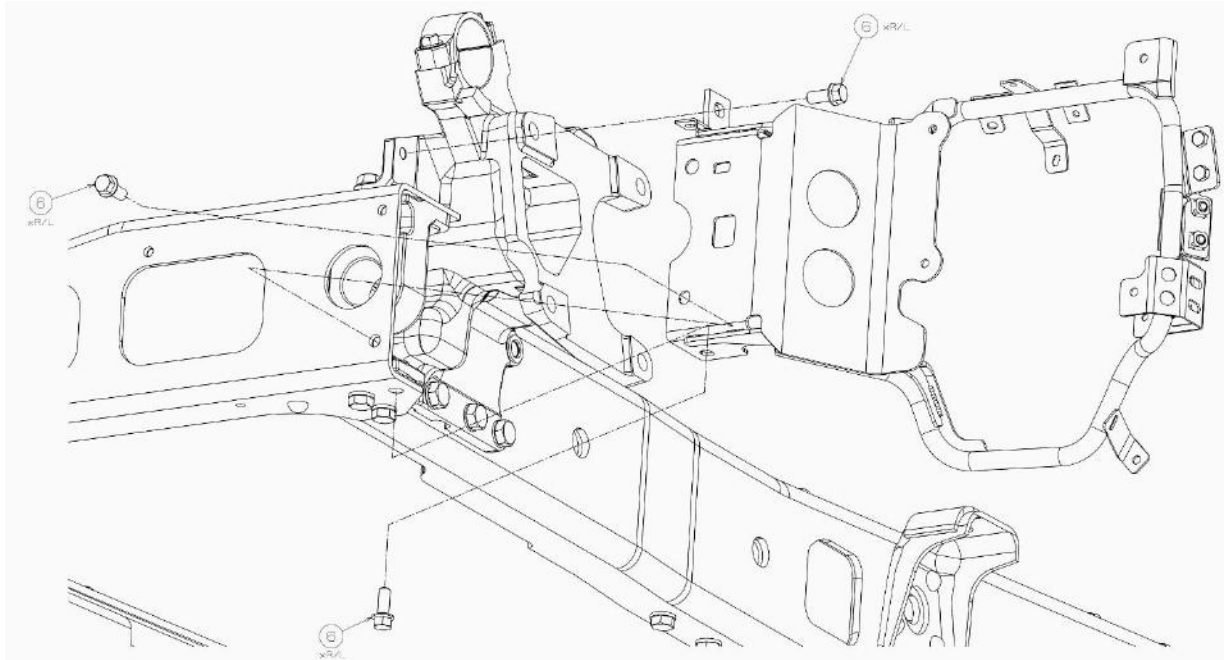

Assembly requirements:

1. The supports ① and ② are connected with bolt ③;
2. Connect the support ④ with bolt ⑤; connect the support to the frame with bolt ⑥ and finally tighten it.

Assembly details:

1. Right support assembly-headlamp mounting (3711340-D17YZ)
1. Left support assembly- headlamp mounting (3711330-D17YZ)
2. Lower support assembly-front headlamp installation (3711360-D17YZ)
2. Lower support assembly-front headlamp installation (3711350-D17YZ)
3. Bolt (Q1840616)
4. Support assembly- headlamp mounting (2803055-D17YZ)
4. Support assembly- headlamp mounting (2803056-D17YZ)
5. Bolt (Q1841020)
6. Bolt (Q1841230)

POWERSTAR

Fit the front leaf spring grease nipple

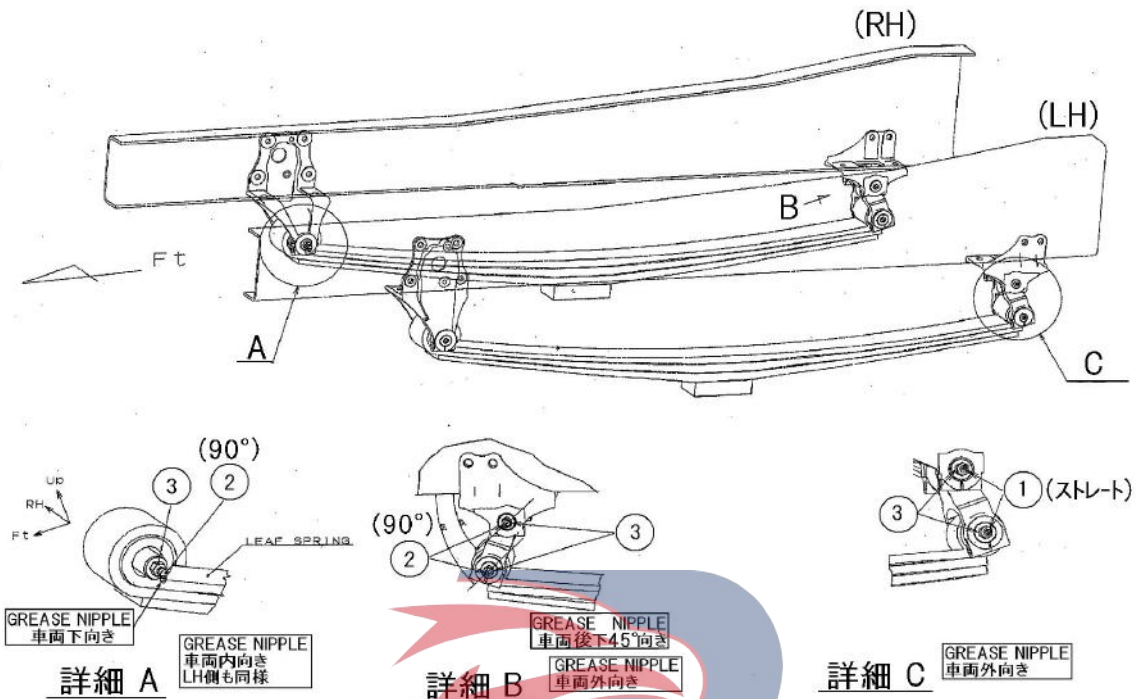

Assembly requirements:

1. Fix the grease nipples ① and ② onto the nipple holder ③, and fit the nipple holder assembly onto the front leaf spring tightly and reliably as shown in the figure.

Assembly details:

1. Grease nipple (Q701B01)
2. Grease nipple (Q701B90)
3. Nipple holder

POWERSTAR

Fit eh front leaf spring assembly

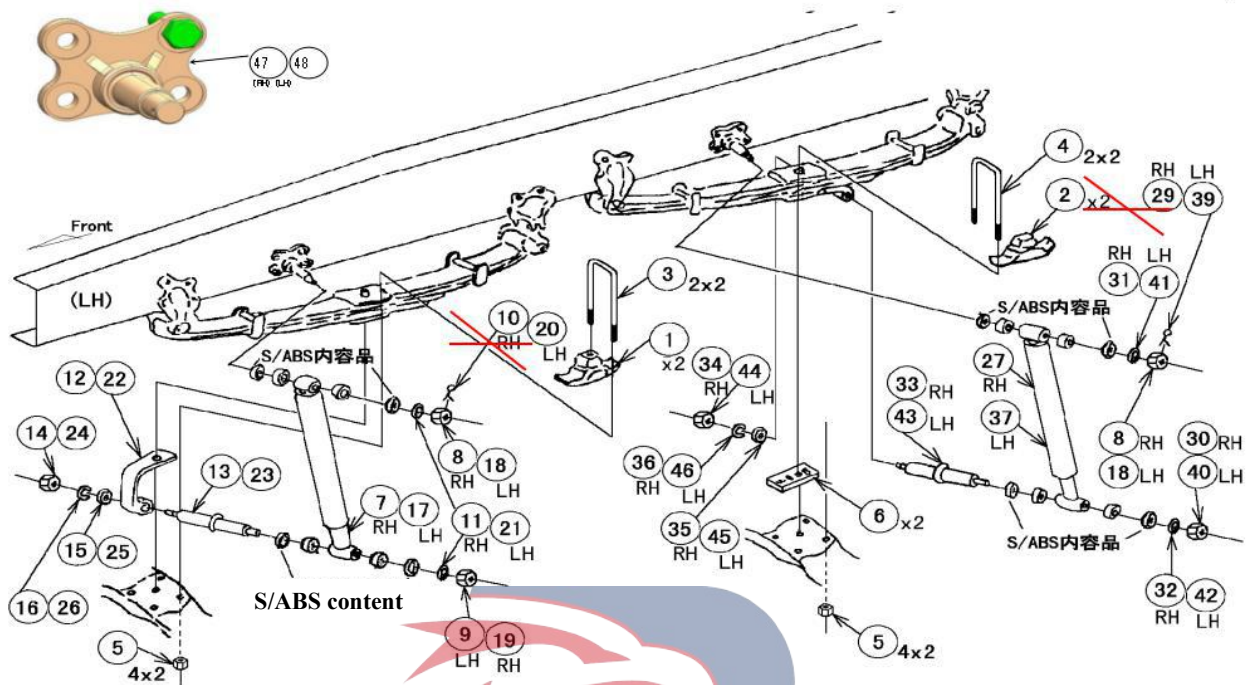

Assembly requirements:

1. Place the platen -- U-shaped bolt on the leaf spring, insert the U-shaped bolt through the leaf spring, place the gasket -- leaf spring on the leaf spring, screw the U-shaped bolt-nut into the U-shaped bolt by several threads, and finally tighten them with a tightening machine;

Nut--U-shaped bolt torque: 491~588N.m;

2. Fit the front shock absorber assembly: Fit the shock absorber assembly according to the figure, and finally tighten it the with a pneumatic wrench tightly and reliably.

Assembly details:

1. Platen-U-shaped bolt
2. Platen-U-shaped bolt
3. U-shaped bolt
4. U-shaped bolt
5. Nut -U-shaped bolt
6. Gasket - leaf spring
7. Shock absorber assembly (2902220-D15EH)
8. Nut (3501811-15)
9. Nut (3501811-15)
10. /()
11. Washer (Q40020)
12. Support assembly
13. Pin

14. Nut (Q341B24T13)
15. Washer
16. Washer (Q40324)
17. Shock absorber assembly (2902220-D15EH)
18. Nut (3501811-15)
19. Nut (3501811-15)
20. /(/)
21. Washer (Q40020)
22. Support assembly
23. Pin
24. Nut (Q341B24T13)
25. Washer
26. Washer (Q40324)
27. Shock absorber assembly (2902230-D15EH)
28. /(/)
29. /(/)
30. Nut (3501811-15)
31. Washer (Q40020)
32. Washer (Q40020)
33. Pin (1516820941)
34. Nut (Q341B24T13)
35. Washer
36. Spring washer (Q40324)
37. Shock absorber assembly (2902230-D15EH)
38. /(/)
39. /(/)
40. Nut (3501811-15)
41. Washer (Q40020)
42. Washer (Q40020)
43. Pin
44. Nut (Q341B24T13)
45. Washer
46. Spring washer (Q40324)
47. Support
47. Bolt(Q151B1440TF2)
47. Washer (2801104-113)
47. Nut(Q341B14)
48. Support

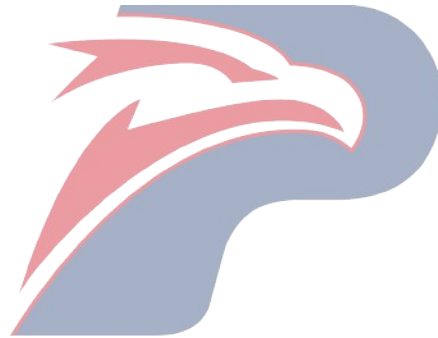

POWERSTAR

48. Bolt (Q151B1440TF2)

48. Washer (2801104-113)

48. Nut (Q341B14)

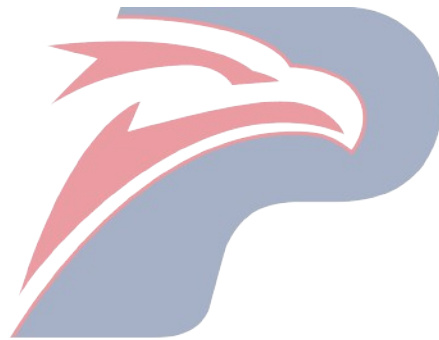

POWERSTAR

Fit the front exhaust pipe assembly (EXZ models)

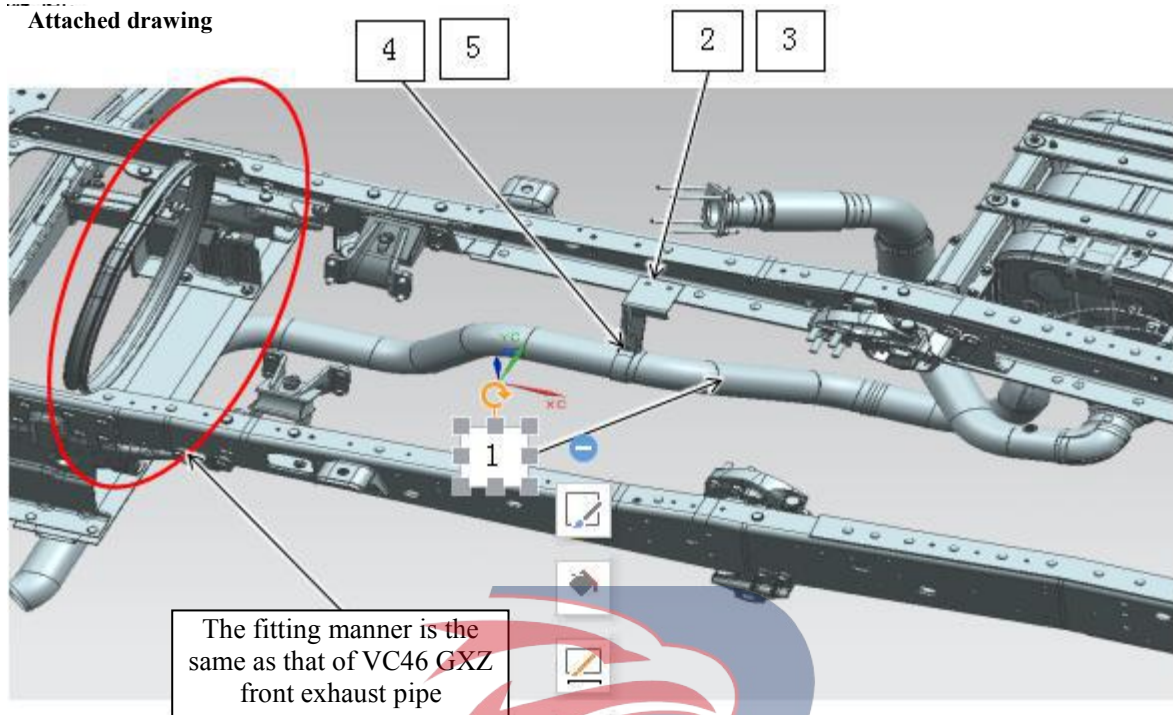

Assembly requirements:

1. Connect one end of the exhaust pipe assembly ① to SCR and fix it using the support;
2. To fix the exhaust pipe assembly ① in turn with bolt ② and nut ③ to the support assembly, to fix the support with bolt ④ and nut ⑤ to the frame, and finally tighten them with the pneumatic wrench.
3. The fitting manner in the red circle is the same as that of the VC646 GXZ type.

Assembly details:

1. Front exhaust pipe assembly (1203940-D17YZ)
2. Bolt (Q1841030)
3. Nut (Q320010)
4. Bolt (Q1840840)
5. Nut (Q32008)

Fit the upper and lower stabilizer bar assembly

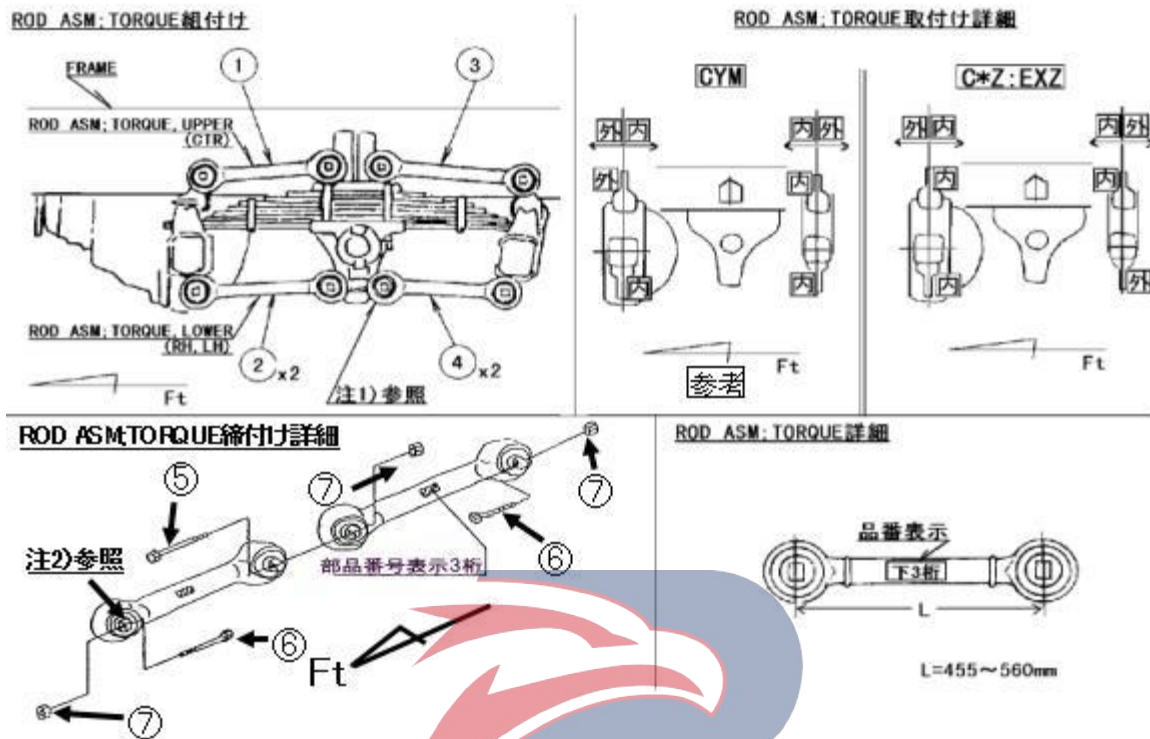

Assembly requirements:

1. The stabilizer bar assemblies ①, ②, ③ and ④ are connected to the retroflexion support assembly with bolts ⑤ and ⑥ and nut ⑦, and finally tighten with a pneumatic wrench. Torque of nut ⑦: 284~343N·m.

Assembly details:

1. Stabilizer bar assembly (2912550-D15EH)
1. Stabilizer bar assembly (2912550-D17YZ)
2. Stabilizer bar assembly (2912650-D15EH)
2. Stabilizer bar assembly (2912550-D17YZ)
3. Stabilizer bar assembly (2912280-D17YZ)
4. Stabilizer bar assembly (2912280-D17YZ)
5. Bolt (2912053-130/C)
6. Bolt (2912054-130/C)
7. Nut (2912055-130/C)

POWERSTAR

Double rear-axle retroflexion support seat assembly

附圖

Attached drawing

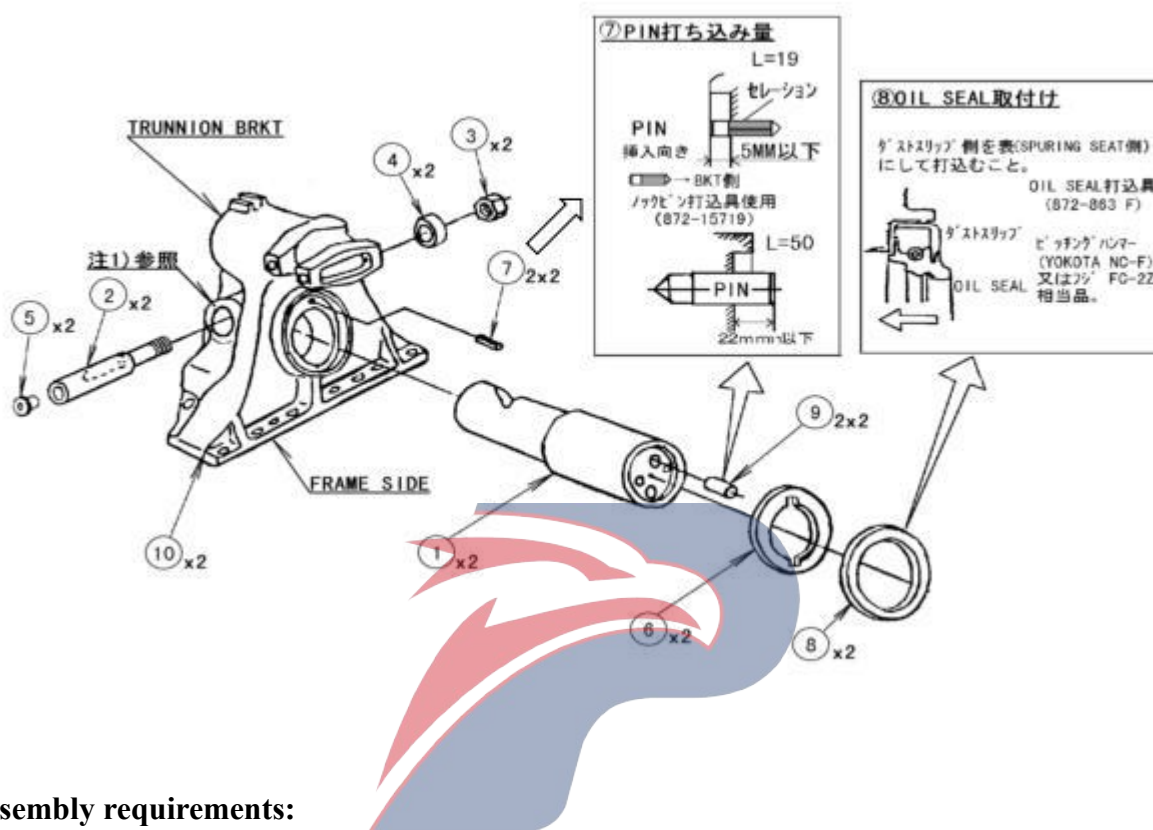

Assembly requirements:

1. Insert the retroflexion shaft ① upwards in the retroflexion support ⑩, push the bolt ② through the dowel hole to secure the retroflexion shaft ①, secure the bolt ② with washer ④ and nut ③, and tighten them with a pneumatic wrench;

Torque of nut ③: 490~686N•m;

2. Put the rubber lining ⑤ into the end of the bolt ② tightly and reliably.

Knock pin ⑦ into the location hole of retroflexion support ⑩ tightly and reliably;

Knock pin ⑨ into the location hole of retroflexion shaft ① tightly and reliably;

3. Finally, knock washer ⑥ and seal ring ⑧ onto the retroflexion shaft ① tightly and reliably;

Assembly details:

1. Retroflexion shaft
2. Bolt
3. Nut (Q341B24T13)
4. Washer
5. Rubber lining
6. Washer
7. Pin (
8. Oil Seal (1513890050)
9. Pin

10. Retroflexion support (2918013-130/C)

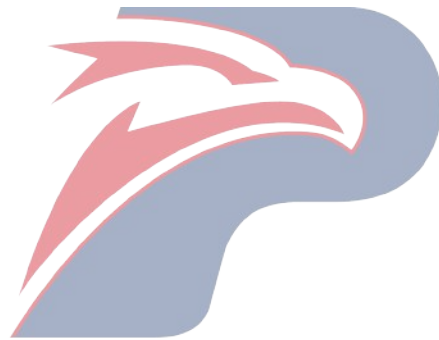

POWERSTAR

Fit the stabilizer bar assembly

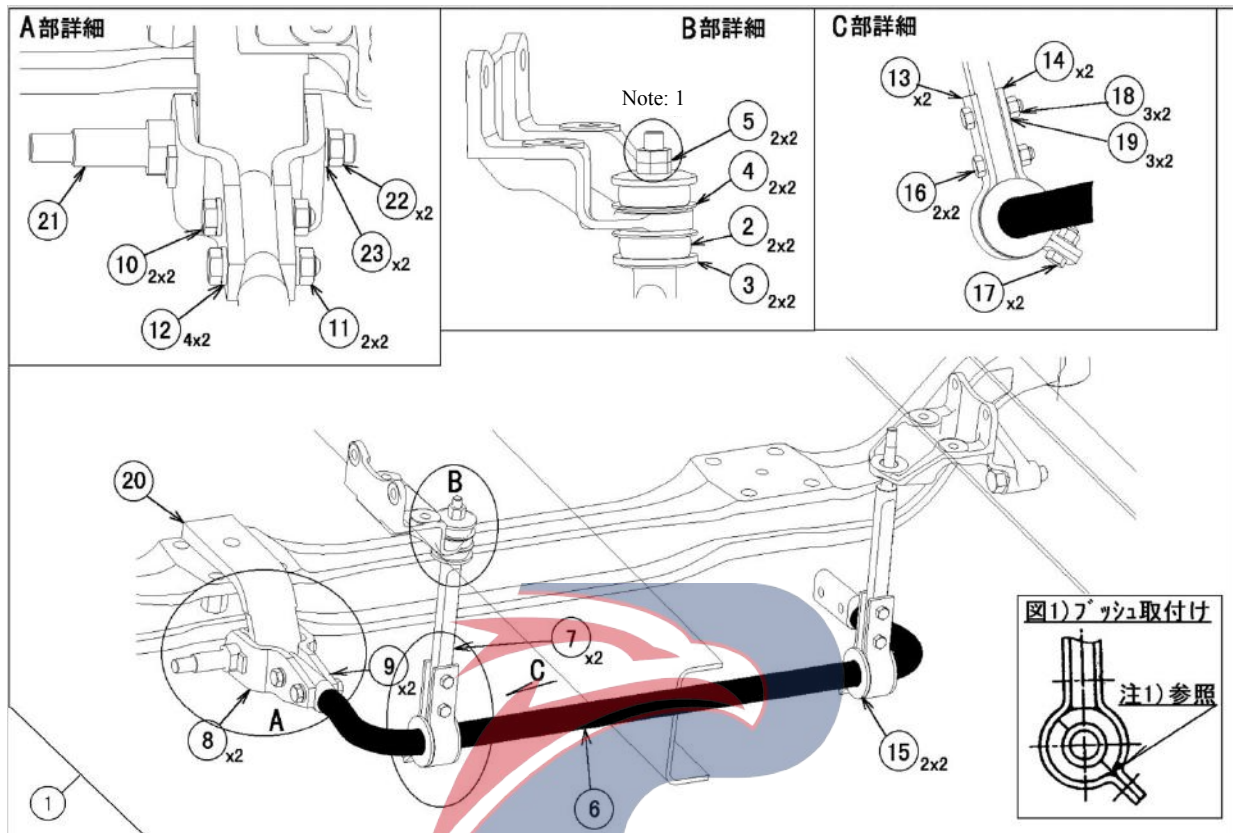

Assembly requirements:

1. The stabilizer bar assembly ① is tightly and reliably fixed on the platen with washers ③ and ④ as well as nut ⑤;
2. Inner torque of nut ⑤: 64-93N.m, and outer torque of nut ⑤: 78-117N.m,
Torque of bolt ⑩: 137-177N.m;
Bolts ⑯ and ⑰ torque: 74-93N.m;
Nut (22) torque: 275-402N.m.

Assembly details:

1. Stabilizer bar assembly (2902310-D17YZ)
2. Lining-stabilizer (2902321-CYR14)
3. Washer (2902322-CYR14)
4. Washer (2902323-CYR14)
5. Nut (Q351B14T15)
6. Stabilizer (1517711361)
7. Connecting rod-stabilizer bar (1517730712)
8. Support-stabilizer (8980129580)
9. Support-stabilizer (8980129590)
10. Bolt (109564700)
11. Nut (911105140)

12. Washer (8980106271)
13. Circumferential clamp-stabilizer bar (1517890272)
14. Circumferential clamp-stabilizer bar (1517890281)
15. Lining-stabilizer (1517790871)
16. Bolt (208512500)
17. Bolt (208512300)
18. Nut (911105120)
19. Spring washer (915108120)
20. Support-stabilizer (1516816620)
21. Pin-stabilizer (8980228741)
22. Nut (911105200)
23. Washer (916145200)

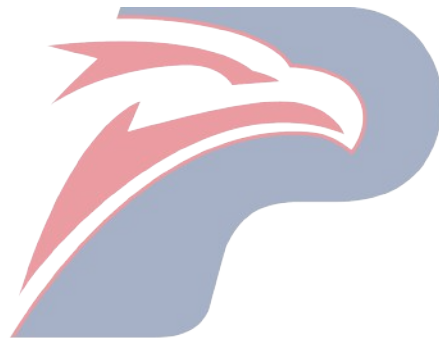

POWERSTAR

Left cover assembly (flat roof cab)

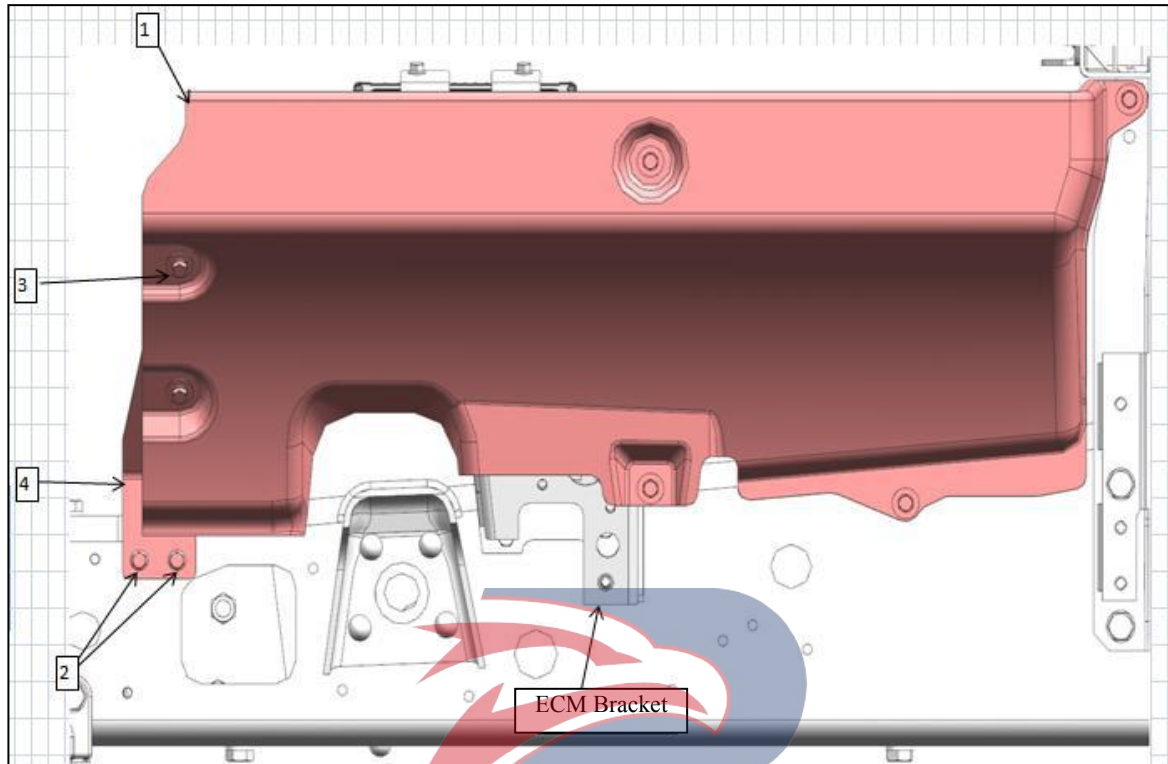

Assembly requirements:

1. Fix the support 3 into the corresponding hole of the frame with the bolt 4.
2. Fix the cover assembly 1 into the corresponding hole with the bolt 2.

Assembly details:

1. Cover assembly
2. Bolt Q1840830
3. Bolt 5002117-P301
4. Support 3102240-D17YZ4

POWERSTAR

Left cover assembly (raised roof cab)

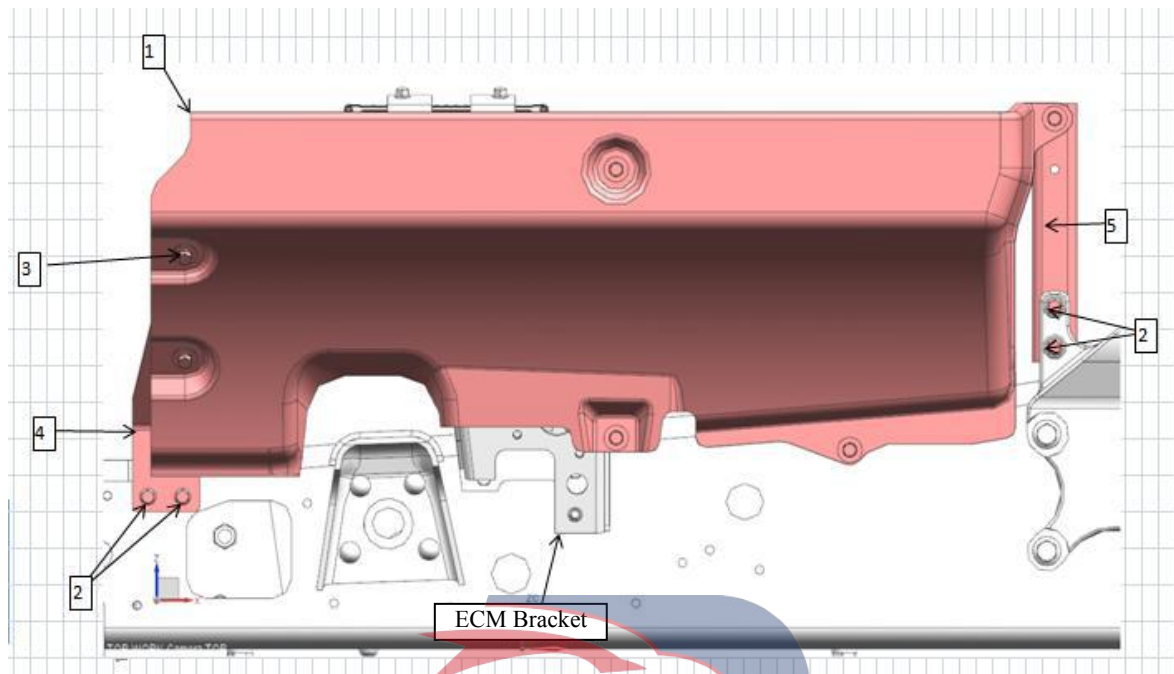

Assembling requirements

1. Fix the support 4 into the corresponding hole of the frame with the bolt 2.
2. Fix the support 5 into the corresponding hole of the frame with the bolt 2.
3. Fix the cover assembly 1 into the corresponding hole with the bolt 3.

Assembling details

1. Cover assembly
2. Bolt Q1840830
3. Bolt 5002117-P301
4. Support 3102240-D17YZ
5. Support 3102250-D17YZ

POWERSTAR